



This is a digital copy of a book that was preserved for generations on library shelves before it was carefully scanned by Google as part of a project to make the world's books discoverable online.

It has survived long enough for the copyright to expire and the book to enter the public domain. A public domain book is one that was never subject to copyright or whose legal copyright term has expired. Whether a book is in the public domain may vary country to country. Public domain books are our gateways to the past, representing a wealth of history, culture and knowledge that's often difficult to discover.

Marks, notations and other marginalia present in the original volume will appear in this file - a reminder of this book's long journey from the publisher to a library and finally to you.

Usage guidelines

Google is proud to partner with libraries to digitize public domain materials and make them widely accessible. Public domain books belong to the public and we are merely their custodians. Nevertheless, this work is expensive, so in order to keep providing this resource, we have taken steps to prevent abuse by commercial parties, including placing technical restrictions on automated querying.

We also ask that you:

- + *Make non-commercial use of the files* We designed Google Book Search for use by individuals, and we request that you use these files for personal, non-commercial purposes.
- + *Refrain from automated querying* Do not send automated queries of any sort to Google's system: If you are conducting research on machine translation, optical character recognition or other areas where access to a large amount of text is helpful, please contact us. We encourage the use of public domain materials for these purposes and may be able to help.
- + *Maintain attribution* The Google "watermark" you see on each file is essential for informing people about this project and helping them find additional materials through Google Book Search. Please do not remove it.
- + *Keep it legal* Whatever your use, remember that you are responsible for ensuring that what you are doing is legal. Do not assume that just because we believe a book is in the public domain for users in the United States, that the work is also in the public domain for users in other countries. Whether a book is still in copyright varies from country to country, and we can't offer guidance on whether any specific use of any specific book is allowed. Please do not assume that a book's appearance in Google Book Search means it can be used in any manner anywhere in the world. Copyright infringement liability can be quite severe.

About Google Book Search

Google's mission is to organize the world's information and to make it universally accessible and useful. Google Book Search helps readers discover the world's books while helping authors and publishers reach new audiences. You can search through the full text of this book on the web at <http://books.google.com/>





Library
of the
University of Wisconsin

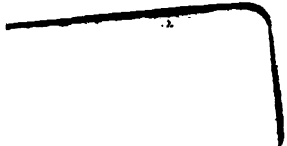



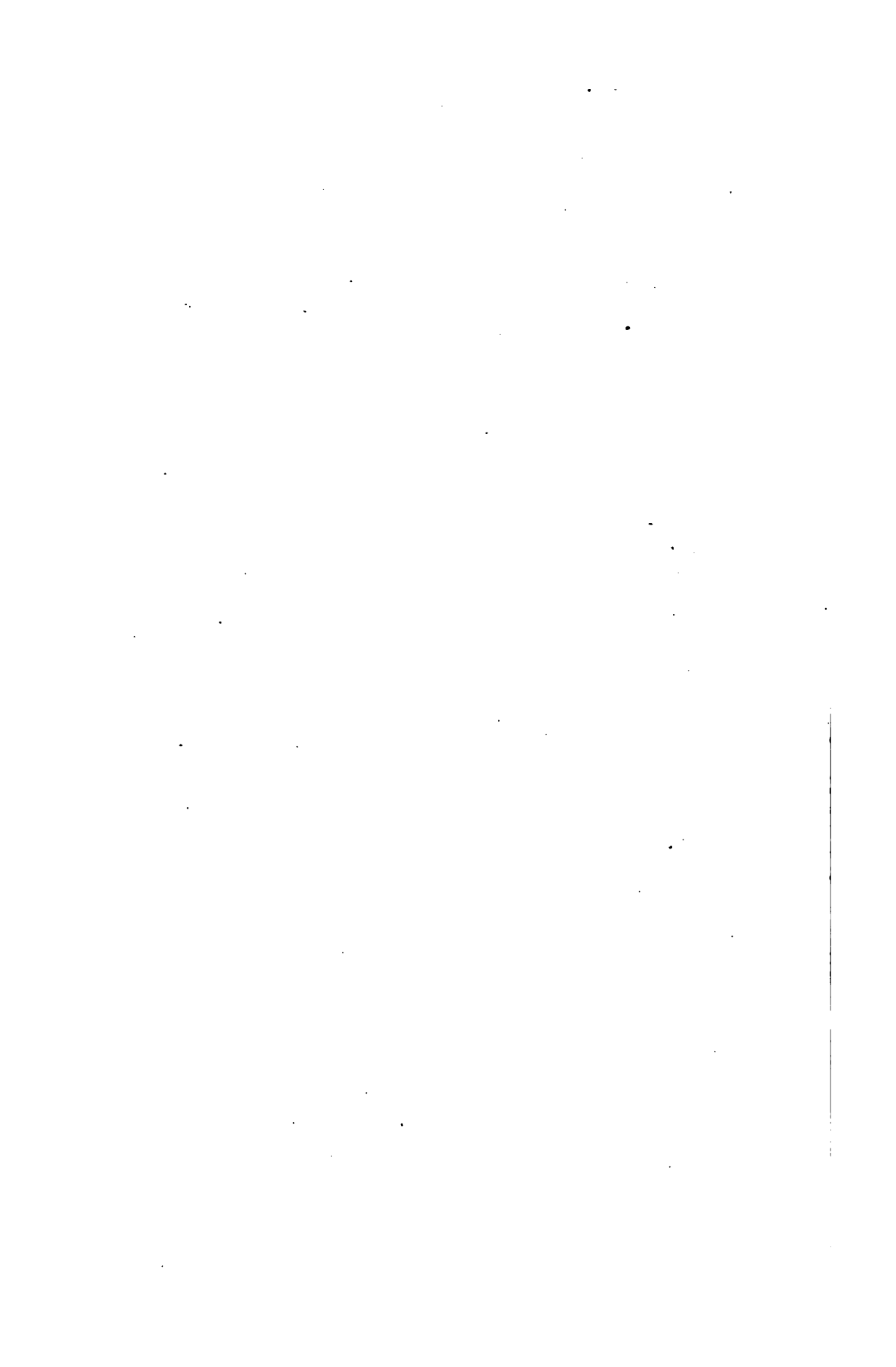



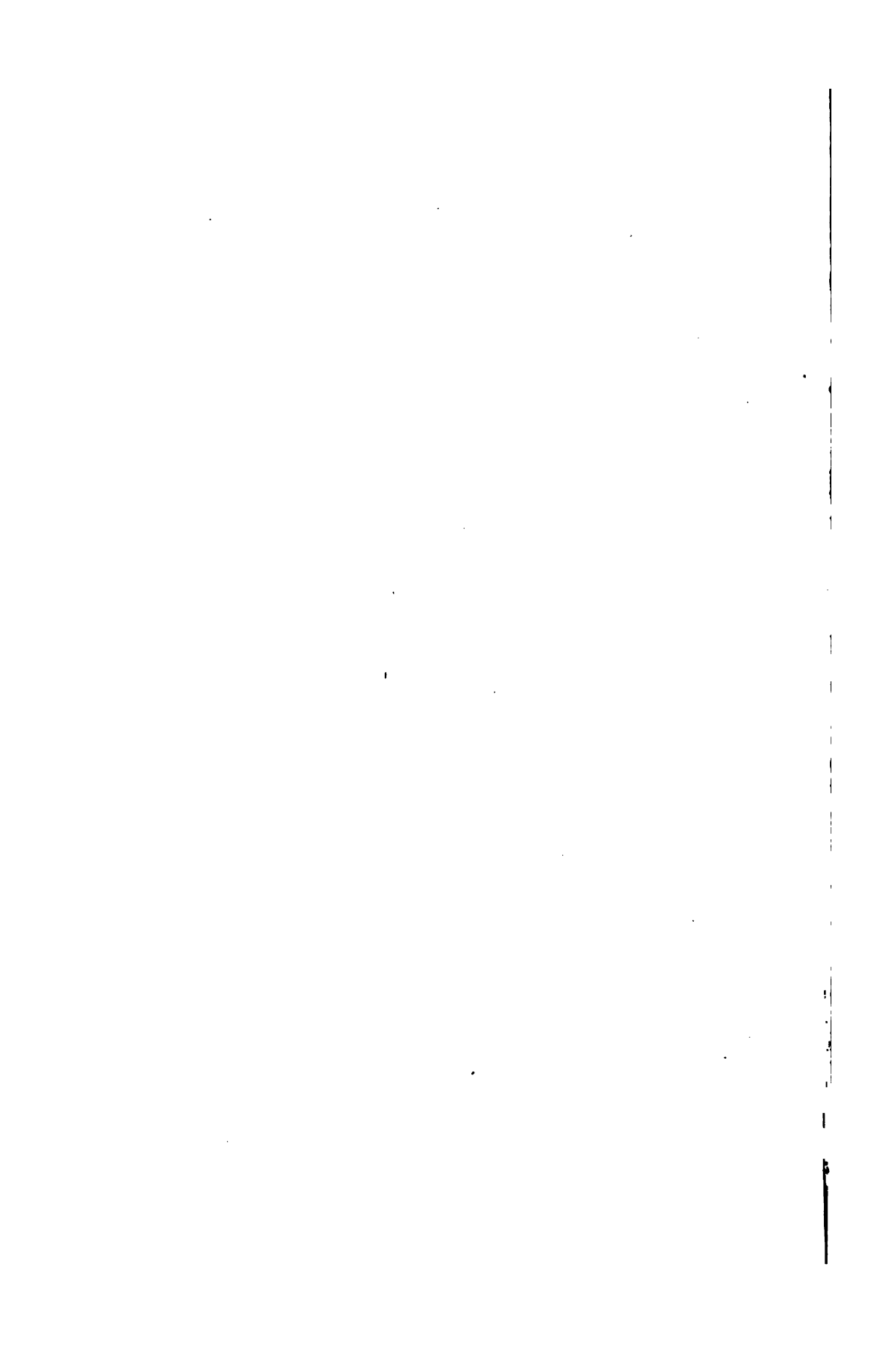

MECHANICAL TECHNOLOGY

MECHANICAL TECHNOLOGY

BEING A TREATISE ON THE
MATERIALS AND PREPARATORY
PROCESSES OF THE MECHANICAL
INDUSTRIES

BY

G. F. CHARNOCK,

M.INST.C.E., M.INST.MECH.E.,

PROFESSOR OF ENGINEERING, CITY OF BRADFORD TECHNICAL COLLEGE



NEW YORK
D. VAN NOSTRAND COMPANY
25 PARK PLACE

1916

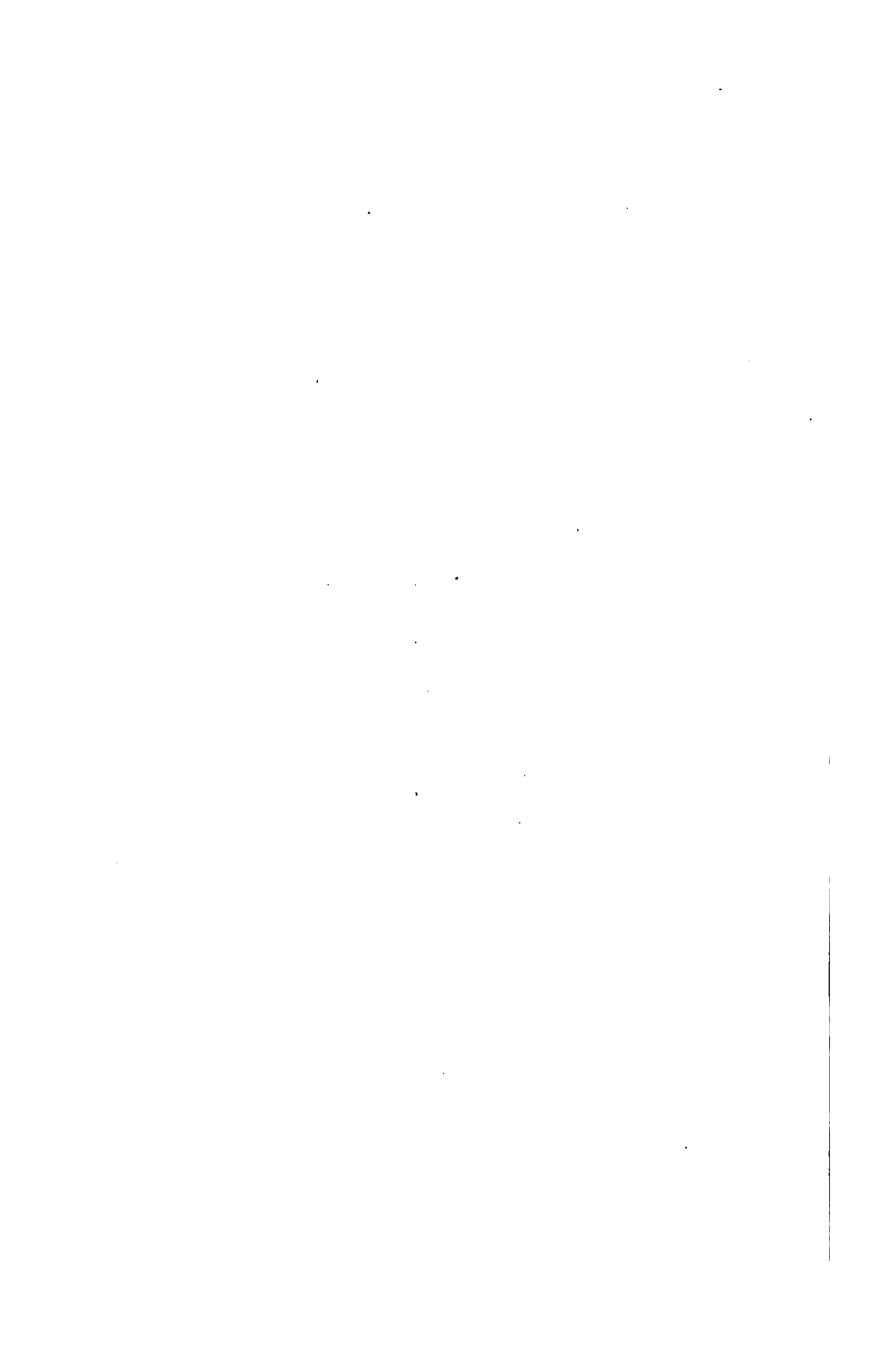

214614

DEC 12 1917

SB
C38

6-62-11

PREFACE.

THE great advance which has been made during recent years as the result of the application of science to industry has served to emphasise the fact that all manufacturing operations are based upon either chemical or mechanical principles. Technology is only another name for applied science, and it has thus become necessary to distinguish between chemical and mechanical technology. Chemical technology has been recognised as a separate branch of applied science for many years past, and the term conveys a distinct meaning which is now well understood. Mechanical technology, on the other hand, has scarcely yet come to be regarded as worthy of treatment on scientific lines. Although there are many excellent treatises on the various branches of the subject, they are for the most part too highly specialised for general use, being intended for the expert or craftsman. Hence it seemed desirable to bring together in one volume a connected and systematic account of the chief operations underlying mechanical trades and handicrafts.

It is believed that a study of the subject will be found of advantage to the majority of workers in the mechanical and allied industries. It should also prove useful to students and apprentices, but it is not to be expected that any description of workshop tools and processes can possibly take the place of actual experience in their use. But it is a fact that when "going through the shops" young engineers rarely devote any time to the foundry or smith's shop, although a knowledge of the operations there carried on is of paramount importance to the designer and constructor. Scarcely less desirable is an acquaintance with the methods of the rolling mill, or of the possibilities of stamping, drawing, etc., processes which are much neglected by the majority of engineers. It is hoped that the present work may form a useful guide for beginners and those with limited time at their disposal, enabling them to acquire some knowledge of the leading features of the work referred to.

To some extent the information contained in the following pages has been obtained by visiting works, and much has been gathered from a study of the leading technical journals, and of the proceedings of the technical societies, of which acknowledgment has been made throughout the text. The experience gained in the workshops and laboratories with which the author has been connected has been largely drawn upon, and several well-known authorities have rendered valuable assistance. To all these sources, the author's grateful acknowledgments are due, and are hereby tendered.

G. F. CHARNOCK.

BRADFORD, 1915.

CONTENTS.

	PAGE
PREFACE	v
<hr/>	
CHAP.	
I. Introduction	1
 PART I. PRODUCTION AND PROPERTIES OF THE CHIEF MATERIALS OF CONSTRUCTION.	
II. Physical Properties of Materials—Specific Gravity, Fusibility, Tenacity, Ductility, Malleability, Toughness, Hardness, etc.	4
III. Iron—Varieties of Iron—Iron and Carbon—Iron Ores— Smelting of Iron in the Blast Furnace—Hot-Blast Stoves —Blowing Engines—Hoists—Blast Furnace Gas	15
IV. Pig Iron—Varieties and Properties of Cast Iron	31
V. Wrought Iron—Refining—Puddling—Shingling—Rolling— Classification of Wrought Iron	35
VI. Steel—Classification and Methods of Manufacture—Mild and Hard Steel—Influence of Carbon Content	57
VII. Crucible Cast Steel—Cementation Process	61
VIII. The Bessemer Process—Chemical Changes in the Converter —The Thomas-Gilchrist, or Basic Bessemer Process	66
IX. The Open-Hearth, or Siemens Process—The Regenerative Furnace—Gas Producers—Furnace-charging Machinery —Continuous Steel-making Plant—Electric Furnaces for the Manufacture of Steel	76
X. Structure of Alloys—Phenomena of Solidification—Steel as an Alloy of Carbon and Iron	101
XI. Special or Alloy Steels—Nickel, Chrome-nickel, Chrome- vanadium, Tungsten, and Manganese Steels—High-speed Tool Steel	114

CHAP.	PAGE
XII. Heat Treatment of Steel—Hardening and Tempering— Annealing—Case Hardening	120
XIII. Non-ferrous metals—Physical and Chemical Properties, Methods of Smelting, and Chief Uses of Copper, Tin, Zinc, Lead, Aluminium, Antimony, and Nickel	130
XIV. Copper-Zinc Alloys—The Brasses	148
XV. Copper-Tin Alloys—The Bronzes	152
XVI. White-metal Alloys—Anti-friction and Bearing Metals— Miscellaneous Alloys	158
XVII. Properties and Uses of the Principal Varieties of Timber— Defects in Timber—Seasoning—Effects of Shrinkage— Preservation of Timber	162
XVIII. Properties and Uses of the Principal Varieties of Stone, and of Cement, Asphalte, Concrete, Asbestos, Abrasive Materials, Carborundum, etc.—Glass	182

OTHER MATERIALS USED FOR MECHANICAL PURPOSES.

XIX. Oils, Lubricants, etc.—Varieties and Methods of Testing .	210
XX. Leather, Indiarubber, and Guttapercha, and their Uses— Leather and Woven Belting—Hydraulic Packing, etc. .	225

PART II.

PREPARATORY PROCESSES.

SECTION A.—PROCESSES DEPENDING UPON THE PROPERTY OF
FUSIBILITY.

XXI. The Production of Castings—Foundry Practice—Precau- tions in Designing Castings—Stresses due to Contraction in Cooling	237
XXII. Methods of Moulding, and the Tools and Appliances employed—Greensand, Drysand, and Loam Moulding, with Examples—Use of Cores, Drawbacks, etc., for Hollow Parts—Three-part Box—Skeleton Patterns .	246
XXIII. Chill Casting—Examples of its Use	303
XXIV. The Foundry, its Arrangement and Equipment—Cupolas, Fans, Blowers, etc.—The Brassfoundry	308

CONTENTS.

ix

CHAP.	PAGE
XXV. The Production of Steel Castings—The Small Converter— Malleable Iron Castings	334
XXVI. Pouring the Molten Metal—Ladles—Cleaning and Fettling Castings	341
XXVII. Defects in Castings and their Remedy—Blow-holes, Honey- comb, Scab, Cold Shuts, etc.	347
XXVIII. Foundry Mixtures—Chemical Analysis—Calculation of Mixtures—Analysis of Castings for different Purposes .	354
XXIX. Aids to Moulding—Plate and Machine Moulding— Examples of Leading Types of Moulding Machines— Core-making Machines—Die Casting	360

PART III.

PREPARATORY PROCESSES—*continued.*

SECTION B.—PROCESSES DEPENDING UPON THE PROPERTIES OF MALLEABILITY AND DUCTILITY.

XXX. Operations of Forging and Stamping—Smith Work and the Production of Forgings—Tools used by the Smith in Forging	411
XXXI. Forging Machinery—Steam and Power Hammers for the Smithy—Tools for Steam Hammer Work	434
XXXII. Classification of Operations in Forging—Upsetting, Drawing Down, Bending, etc.—Welding	472
XXXIII. The Smithy: Its Arrangement and Equipment—Simple Examples of Hand Forging	492
XXXIV. The Forge and its Equipment—The Forge Hammer— The Hydraulic Forging Press	520
XXXV. Examples of Heavy Forging in Iron and Steel—Engine Connecting Rods, Crankshafts, etc.	540
XXXVI. Drop Forging or Stamping, and Examples of its Use— Nut and Bolt Forging Machine—Bending Press, or “Bull-dozer”	547
XXXVII. Production of Parts by Rolling—Action of Rolls—The Rolling Mill	562
M.T.	<i>b</i>

CONTENTS.

CHAP.		PAGE
XXXVIII.	Wire-drawing, and Wire-drawing Machinery—The Draw-bench—The Continuous Process	575
XXXIX.	The Manufacture of Tubes—Wrought Iron Pipe—Welded and Brazed Tubes—Solid-Drawn Tubes—The Draw-bench for Tubes—Weldless Steel Tubes—Lead Pipe, etc.—Extrusion of Metals	589
XL.	The Manipulation of Sheet Metals by Flanging, Dishing, Drawing, Embossing, etc.—The Drawing Press and Examples of Work—Coining Press	603
—————		
APPENDIX.	Books of Reference	621
INDEX		623

MECHANICAL TECHNOLOGY.

CHAPTER I.

INTRODUCTION.

TECHNOLOGY may be defined as that branch of knowledge which deals with the processes and apparatus employed in the conversion of the raw products of nature into finished articles of utility.

It will be found that the object of all manufacturing processes is to bring about a change either (1) in the internal constitution or composition of the material, or (2) in the external shape or appearance. Hence, technology may be divided into two great branches, distinguished as (1) chemical, and (2) mechanical, according to which of the two methods of conversion is employed.

Many manufacturing processes are partly chemical and partly mechanical. For instance, the smelting of iron from the ore must be regarded as a chemical operation, whilst the rolling, forging, casting, machining, etc., to which the metal is subsequently subjected, belong distinctly to the domain of mechanical technology.

It will be seen that mechanical technology may be sub-divided into sections, each of which is concerned with the working of some particular kind of raw material, as of metal, or of wood,

or again, of some textile material, etc. In every case, however, the same distinguishing characteristic is observed, viz.: that the external form only undergoes alteration, the chemical composition of the material operated upon remaining unchanged.

Strictly speaking, mechanical technology embraces all mechanical trades or handicrafts, for each of which some special technical knowledge is required. But there are many simple operations, and many tools the use of which is common to a number of widely differing trades. The subject may therefore be treated in either of two ways. Firstly, as a description of methods of manufacture from the raw material to the finished product, or secondly, as an explanation of general principles underlying the action of machines and processes without reference to any particular trade. In all branches of engineering and the allied industries, the chief requirement is a knowledge of mechanical technology on specialised lines according to the first method of treatment, but in the most useful arrangement of the subject, it is desirable to retain as far as possible a scientific classification of the means of production to admit of the general application of the principles involved.

Articles of utility and the various parts of machines and structures are manufactured from the raw material by taking advantage of some property which such material possesses in a marked degree. Thus, by virtue of the property of plasticity, some substances may be moulded into shape merely by the application of external force as in the manufacture of pottery, and in the case of metals in stamping, embossing, coining, etc. Many materials, especially when heated, may be reduced from one form to another by hammering, thus bringing into play the property of malleability, on which the process of forging depends. Again, some substances when raised to a high temperature possess sufficient fusibility to admit of being cast into moulds, thus giving rise to the process of founding. Further, there are many manufacturing processes which depend upon the cutting away or removal of superfluous material by means of shears, saws, chisels, drills, lathe and planer tools, etc. In such cases it is important that the strength, elasticity, hardness and toughness of the material operated upon should receive full consideration.

The most useful treatment of the subject would therefore appear to be that which proceeds along lines corresponding to the successive operations which are followed in the workshop, commencing with the raw material, which is first subjected to processes of casting, rolling, forging, etc., and is finally reduced to the required form by cutting or "machining." In this way the subject is naturally divided into four parts, as follows:—

- I. The preparation and properties of the raw material.
- II. The production of castings, by taking advantage of the property of fusibility.
- III. The production of bars, plates, forgings, etc., by utilising the properties of malleability and ductility.
- IV. The finishing of castings, forgings, etc., by machining.

It is proposed to deal with the first three parts in the present volume, the fourth being of sufficient importance to warrant separate treatment.

PART I.
PRODUCTION AND PROPERTIES
OF THE CHIEF MATERIALS OF CONSTRUCTION.

CHAPTER II.

PHYSICAL, CHEMICAL, MECHANICAL, ETC., PROPERTIES
OF MATERIALS.

THE properties of the various raw materials may be classified as (1) physical, (2) chemical, and (3) mechanical.

The **Physical properties** include (a) specific gravity; (b) specific heat; (c) fusibility; (d) conductivity for heat and electricity; and (e) magnetic properties.

(a) *Specific gravity* is the ratio which the weight of a cubic inch of the body bears to the weight of a cubic inch of distilled water at the normal temperature of 60° F. Or, instead of a cubic inch a cubic foot may be taken. Thus, a cubic foot of cast iron weighs 452 lbs., and of water 62·425 lbs. The specific gravity of cast iron is then $452 \div 62\cdot425 = 7\cdot23$.

(b) *Specific heat* is the ratio which the quantity of heat required to raise 1 lb. of the given substance through one degree bears to the quantity of heat required to raise the temperature of 1 lb. of water one degree. In measuring the quantity of heat the unit employed is the British Thermal Unit (B. Th. U.), which is the amount of heat required to raise the temperature of 1 lb. of water 1° F.

Of all known substances, water has the greatest specific heat. To raise the temperature of 1 lb. of water 1° F. requires one unit of heat. But it is found that one unit of heat is capable of raising the temperature of 7·7 lbs. of cast iron through 1° F. The specific heat of cast iron is therefore $1\cdot0 \div 7\cdot7 = 0\cdot1298$.

(c) *Fusibility* is the property of becoming liquid at high temperatures. In melting, most metals and alloys pass at once from the solid to the liquid state. There are, however, a few exceptions—notably white cast iron and platinum—which pass through an intermediate or pasty condition shortly before fusion. Almost all metals expand on melting, and contract on solidification. The exceptions are antimony and bismuth, which expand on solidifying, and impart the same property to their alloys. Fusibility must not be confounded with fluidity, which is quite a different property. The degree of fluidity of different metals when melted varies widely, and plays an important part in the production of castings.

(d) *Conductivity for Heat and Electricity*.—As a rule, metals are good conductors of both heat and electricity, in which respect they differ from non-metallic bodies. Electrical conductivity is seriously affected by the presence of impurities, and falls off rapidly with a rise in temperature. The relative conducting power is therefore given for metals in a pure state and at normal temperature (60° F.), and is referred to silver as standard, that metal being the best known conductor of both heat and electricity.

(e) *Magnetic properties*.—What are termed magnetic metals, viz., iron, steel, nickel, cobalt, chromium and manganese, are attracted by a magnet. The magnetic power of nickel is very slight compared with iron and steel, and the other metals still less so. A number of substances, including bismuth, phosphorus, antimony, zinc, lead, silver and copper, are repelled, although feebly, from the poles of a magnet, and are therefore said to be diamagnetic. It is well known that steel, and, to some extent, cast iron, can retain permanently the magnetism imparted to it. Soft wrought iron, on the other hand, is temporarily magnetic, i.e., only so long as it remains under the influence of a permanent magnet, or of magnetic induction.

As already explained, a consideration of the **Chemical properties** of the various substances used for industrial purposes falls within the province of chemical, rather than mechanical, technology. At the same time, it is scarcely possible to draw a strict line of demarcation, and a knowledge of chemistry will be found extremely useful in almost all manufacturing operations.

The **Mechanical properties** comprise:—(f) tenacity;

(g) elasticity ; (h) hardness ; (i) toughness ; (j) malleability ; and (k) ductility.

(f) *Tenacity* is that property which enables a substance to resist fracture under the action of tensile stress. In practice, it is expressed in tons per square inch of sectional area. The tenacity of any given material is ascertained by actual experiment in the testing machine, a specimen of known dimensions being pulled asunder and the load noted. The tenacity of metals is considerably affected by the presence of impurities, by mechanical treatment, as in forging and rolling, and by variation in temperature. A consideration of the strength of materials is not limited to the action of tensile stress, but must also include compression or crushing stress, shear, bending, and torsion. For this part of the subject, the reader must be referred to a separate text-book.

(g) *Elasticity*.—Under the action of stress, material undergoes a change in shape, and is said to be strained or deformed. Elasticity is that property which causes a body to spring back to its original form on the removal of the straining force. Up to a certain point, termed the *limit of elasticity*, the material remains perfectly elastic, and recovers itself completely when the load is removed. If, however, the stress be carried beyond the limit of elasticity, the body fails to return to its original form when relieved, and is said to have taken a *permanent set*. The limit of elasticity may therefore be defined as the maximum stress which can be resisted without producing permanent set.

The *modulus of elasticity* is a number or constant for any given material by means of which the amount of deformation for any load within the elastic limit may be calculated. To take an example, suppose a tie-rod of sectional area A square inches and length L inches carries a load of W tons, and let e inches be the change in length, or extension, produced by W . Then the *tensile*

stress = $\frac{W}{A}$ tons per square inch. The *strain* is defined as change in length expressed as a fraction of the original length, or strain = $\frac{e}{L}$. Now the fraction $\frac{\text{stress}}{\text{strain}}$ is called the modulus of elasticity = E , so that

$$E = \frac{\text{stress}}{\text{strain}} = \frac{W}{A} \div \frac{e}{L} = \frac{W \times L}{A \times e} \text{ tons per square inch.}$$

If E be given, and it is required to find the amount of extension, the formula becomes

$$e = \frac{WL}{EA}.$$

For example, take the case of an iron wire 10 feet long and of $\frac{1}{8}$ square inch sectional area, which is hung vertically, and has a load of 450 lbs. attached to its lower extremity. The value of E being = 12,850 tons per square inch, the stretch of the wire will be

$$e = \frac{WL}{EA} = \frac{450 \times 10 \times 12}{2,240 \times 12,850 \times \frac{1}{8}} = \cdot 015 \text{ inch.}$$

A body which does not recover its original form on the removal of the load, but retains the impression made upon it, is said to be plastic. In this sense, *plasticity* may be regarded as the absence of elasticity. Wet clay is typical of this property in a high degree, and it may be developed to a greater or less extent in many metals.

(h) *Hardness* is commonly defined as the resistance offered by a body to penetration. In the absence of any standard method of producing and measuring the amount of penetration, widely different meanings have been attached to the term, and although hardness is a property of very great importance for many practical purposes, very little concerning it is to be found in text-books. Three distinct methods of measuring hardness have been proposed, viz. :—(1) the scratch method, which in principle is that employed by a workman who makes use of a file for the purpose; (2) the indentation method, and (3) by the rebound of a small hammer or ball.

It was in the first place proposed to measure the hardness of any body by its ability to scratch certain standard substances, or of being scratched by them. This standard of hardness was devised by Mohs, who selected ten well-known minerals and arranged them in order so that any one of them will scratch all those which precede it, and be scratched by all which follow, thus :—

Mohs' Scale of Hardness.

- | | |
|---------------|---------------------------|
| 1. Talc. | 6. Orthoclase (Feldspar). |
| 2. Gypsum. | 7. Quartz. |
| 3. Calcite. | 8. Topaz. |
| 4. Fluorspar. | 9. Corundum. |
| 5. Apatite. | 10. Diamond. |

Thus the diamond will scratch all other substances, but is scratched by none. Suppose a body is not scratched by, nor is able to scratch, topaz, its hardness is said to be 8. If a certain substance will scratch quartz, but not topaz, then its hardness is said to be between 7 and 8. Professor Turner, of Birmingham, has elaborated the *scratch method* for the determination of hardness, and has devised for the purpose an instrument termed the sclerometer. A diamond is carried upon one end of a balanced arm, and is caused to make a series of scratches on the polished surface of the metal to be tested. The hardness number is taken to be the load in grammes on the diamond which is required to produce on a standard metal surface a scratch of standard width as measured by a microscope. The operation is a rather delicate one, requiring considerable skill, and scarcely seems suitable for everyday use in the workshop. According to the second method, hardness is measured by means of an *indentation test*, of which the best known and most extensively used is that due to the Swedish engineer, Brinell. It consists in pressing a hardened steel ball into the surface to be tested under a standard load. The diameter of the impression produced is measured, and from it the hardness number is calculated as follows :—

$$\text{Hardness number} = \frac{\text{Total load } P}{\text{Curved area of impression}}$$

But if D = diameter of ball, and d = diameter of impression,

$$\text{Curved area of impression} = \frac{\pi D}{2} (D - \sqrt{D^2 - d^2}).$$

$$\text{Hence, hardness number} = \text{H.N.} = \frac{P}{\frac{\pi D}{2} (D - \sqrt{D^2 - d^2})}.$$

The machine used is shown in Fig. 1. A small hydraulic ram acting downwards carries a standard ball of 10 m.m. diameter, which is pressed into the test piece under a standard load of 3,000 kilogrammes for iron and steel, and of 500 kilogrammes for softer metals. The test piece is placed on the table, the height of which is adjustable by screw and hand wheel. The pressure produced by means of a small hand pump may be read off directly from the gauge, but a dead weight control is also provided as shown, which limits the maximum pressure to

that required for the test. It is very important that the pressure should be maintained on the specimen for exactly the standard time of 15 seconds in the case of iron and steel, and

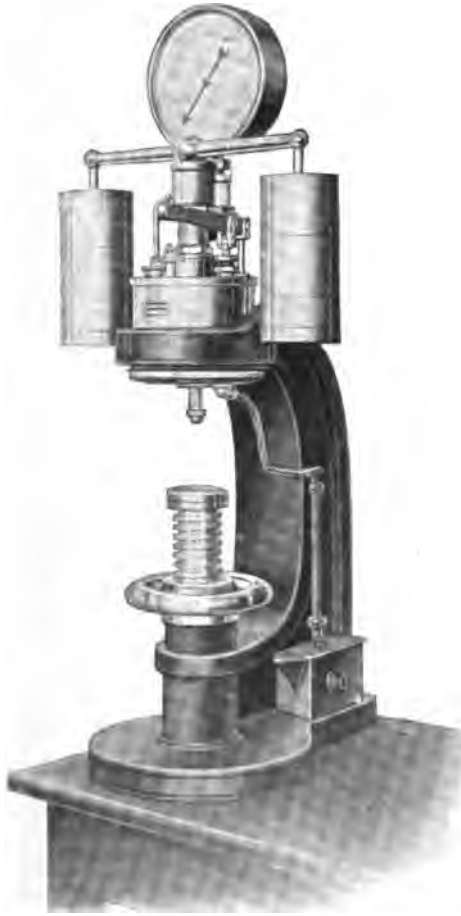

FIG. 1.—Brinell's Hardness Tester.

of 30 seconds for softer materials. The diameter of the impression is measured by means of a microscope capable of reading to $\frac{1}{20}$ millimetre. The machine has been largely adopted, and has given good results.

In the third type of instrument invented by Mr. A. F. Shore, and known as the *Scleroscope* (Fig. 2), hardness is taken to be proportional to the rebound of a small hammer which is allowed to fall by its own weight upon the surface the

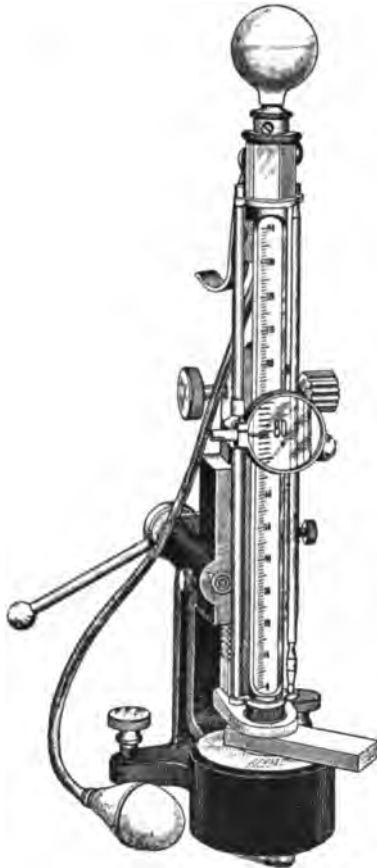

FIG. 2.—Shore's Scleroscope.

hardness of which is to be measured. The hammer takes the form of a small cylindrical plunger, the lower end of which is pointed, and fitted with a small diamond of standard size. The hammer is guided in a vertical tube of glass, at the top of which it is held in position by a catch. This is released and the hammer allowed to fall, by compressing a rubber bulb which may be held in the hand. By pressing the rubber bulb at the top of the tube and releasing it suddenly, the hammer is sucked up the tube, engaging with the catch at the top. The height of fall, and therefore the velocity of impact, is a constant quantity, and the height of fall (about 10 inches), the weight of the hammer (40 grains), and the area of contact are so adjusted that the force due to impact exceeds the elastic limit of all substances. The degree of hardness is given by the height of the rebound of the hammer, which is read off on a scale graduated on the glass tube. With a little practice, this may be done quite accurately, a lens being provided to read slight differences quite positively. The scale adopted is an arbitrary one, on which hard steel has a value of 100. There would seem to be no doubt that under certain conditions the scleroscope is capable of furnishing valuable

hardness of which is to be measured. The hammer takes the form of a small cylindrical plunger, the lower end of which is pointed, and fitted with a small diamond of standard size. The hammer is guided in a vertical tube of glass, at the top of which it is held in position by a catch. This is released and the hammer allowed to fall, by compressing a rubber bulb which may be held in the hand. By pressing the rubber bulb at the top of the tube and releasing it suddenly, the hammer is sucked up the tube, engaging with the catch at the top. The height of fall, and therefore the velocity of impact, is a constant quantity, and the height of fall (about 10 inches), the weight of the hammer (40 grains), and the area of contact are so adjusted that the force due to impact exceeds the elastic limit of all substances. The degree of hardness is given by the height of the rebound of the hammer, which is read

PHYSICAL, ETC., PROPERTIES OF MATERIALS. 11

results, and of giving the relative hardness in certain groups of material, although a comparison can only be instituted between individual members of the same group. The scleroscope has the great advantage that no specially prepared surface or specimen is required, and that it may be applied directly to any actual object the hardness of which is to be measured, without in any way damaging the surface. It must, however, be admitted that in certain cases, the scleroscope test is not reliable. Thus, indiarubber is found to give a hardness number 23, *i.e.*, greater than mild steel; soft pine will give 40, or twice the value for grey cast iron; and glass, 130, a value higher than the hardest steel. On the other hand, for most ordinary metals a fairly close coincidence with other methods has been found to exist, as the following table, due to Professor Turner, will show.

Comparison of Hardness Scales.

Metal.	Turner.	Brinell ÷ 6.	Shore.
Lead	1·0	1·0	1·0
Tin	2·5	2·5	3·0
Zinc	7·5	6·0	7·0
Copper (soft)	—	8·0	8·0
Copper (hard)	12·0	—	12·0
Softest Iron	14·5	15·0	—
Mild Steel	16 to 24	21·0	22·0
Soft Cast Iron.	24	21 to 24	24·0
Rail Steel	26 to 35	24·0	27·0
Hard Cast Iron	35·0	36·0	40·0
Hard White Iron	75·0	72·0	70·0
Hard Steel	93·0	—	95·0

Order of Hardness of Common Metals.

- | | | |
|------------------|---------------|-----------|
| 1. Steel. | 4. Copper. | 8. Gold. |
| 2. Wrought Iron. | 5. Aluminium. | 9. Tin. |
| 3. Platinum. | 6. Silver. | 10. Lead. |
| | 7. Zinc. | |

(i) *Toughness* is the resistance offered to fracture by repeated bending or twisting. A common test for wire is to ascertain the number of times a short length can be bent to and fro through a certain fixed angle before breaking.

(j) *Malleability* is the property which enables a body to be extended in all directions by hammering or rolling. The degree of malleability is gauged by the thinness of the leaf or foil which it is possible to produce. Gold is the most malleable of all metals, and it is stated that gold leaf $\frac{1}{300,000}$ of an inch in thickness may be obtained. Malleability depends partly on hardness and partly upon tenacity, and is much affected by the presence of impurities and by temperature. The relative order of malleability for the commoner metals at ordinary temperatures is as follows:—

Order of Malleability by Hammering.

- | | | |
|---------------|--------------|-------------|
| 1. Gold. | 4. Copper. | 8. Zinc. |
| 2. Silver. | 5. Tin. | 9. Iron. |
| 3. Aluminium. | 6. Platinum. | 10. Nickel. |
| | 7. Lead. | |

Order of Malleability by Rolling.

- | | | |
|----------|---------------|--------------|
| 1. Lead. | 4. Silver. | 7. Platinum. |
| 2. Tin. | 5. Aluminium. | 8. Iron. |
| 3. Gold. | 6. Copper. | |

(k) *Ductility* is usually defined as the property which enables a body to be drawn out in the direction of length, or in other words, to be drawn into wire. This property depends very largely upon tenacity, and to some extent upon hardness. The ultimate strength or tenacity of the wire when formed must always exceed the resistance encountered in pulling the metal through the hole in the draw plate. The ductility of a metal is usually much less hot than when cold, hence all wire is drawn cold. Glass, on the other hand, is extremely ductile when hot, and may be drawn out into very fine thread. Gold is the most ductile of all metals, and it is on record that an ounce of gold has been drawn into a wire 1,300 miles long. At ordinary temperatures the scale of ductility is as follows:—

Order of Ductility (Wire-drawing).

- | | | |
|--------------|---------------|-----------|
| 1. Gold. | 4. Iron. | 8. Zinc. |
| 2. Platinum. | 5. Copper. | 9. Tin. |
| 3. Silver. | 6. Aluminium. | 10. Lead. |
| | 7. Nickel. | |

Table of Physical and Mechanical Properties of Metals.

Substance.	Specific gravity.	Weight in lbs.		Specific Heat at 60° F.	Melting Point. F.°	Coefficient of Linear Expansion per 1° F. Temperature between 32° and 212° F.	Conductivity. Silver 100 at 60° F.		Tenacity in tons per sq. in.	Modulus of Elasticity. Tons p. sq. in.	Ductility. Elongation per cent.
		Per cub. ft.	Per cub. in.				Heat.	Electricity.			
Aluminium.	2.56	160	.092	.2143	1160	.0000231	32	66	8	5,500	15 in 8"
Antimony . . .	6.72	420	.243	.0508	1120	.00000602	4	3.5	.5	—	—
Bismuth . . .	9.7	606	.35	.0308	480	.00000773	1.8	1.3	1.45	—	—
Copper . . .	8.9	556	.32	.0965	1900	.00000955	74	96	13.5	7,250	48 in 8"
Gold . . .	19.3	1,206	.698	.0324	1950	.00000830	53	70	9	—	—
Iron, Cast (grey).	7.23	452	.26	.1298	2250	.00000618	12	—	7.5	7,500	Nil.
Iron, Wrought . . .	7.87	491	.284	.1146	2900	.00000656	10	16	22	12,000	20 in 8"
Lead . . .	11.36	710	.41	.0314	650	.0000158	8.5	7.6	1.5	320	55 in 8"
Mercury . . .	13.6	850	.49	.0333	-39	.00003333	1.3	1.7	—	—	—
Nickel . . .	8.9	556	.32	.1086	2640	—	—	8	—	—	—
Platinum . . .	21.5	1,343	.777	.0324	3200	.00000530	8.4	8	21	10,200	—
Silver . . .	10.5	656	.37	.0570	1750	.00001060	100	100	16	4,500	—
Steel (mild) -12 % C.	7.87	491	.284	.1165	2900	—	10	16	28	13,500	25 in 8"
Steel (strong) .4 % C.	7.85	490	.283	—	2700	—	—	12	40	14,000	15 in 8"
Steel (crucible) un- hardened .9 % C.	7.83	488	.282	.1184	2500	—	—	10	60	14,500	3 in 8"
Tin . . .	7.29	455	.263	.0662	450	.00001207	15	13	2.2	1,560	79 in 8"
Zinc . . .	7.1	443	.256	.0956	770	.00001633	28	27	3.3	5,980	—

Another definition of ductility is very generally adopted in practical work, especially in drawing a distinction between *ductile and brittle materials*. In making a tensile test, ductile material will show quite an appreciable amount of stretch or elongation before fracture takes place. Brittle material, on the other hand, exhibits no perceptible increase in length under similar circumstances. A convenient measure of ductility is obtained by expressing the increase in length as a percentage of the original length of the specimen. For instance, upon a piece of mild steel, two centre punch marks are made at a distance of 10 inches apart. The piece is then broken in the testing machine, and the distance measured after fracture is found to be (say) 12·5 inches. The amount of elongation is therefore 2·5 inches, which is expressed as $\frac{2\cdot5}{10} \times 100 = 25$ per cent. of the original length.

Occurrence of the Elements in Nature.

According to a careful estimate by the American naturalist, Professor Vogt, the composition of the earth's crust, including also air and water, may be taken as follows:—

	Per cent.		Per cent.
Oxygen	50	Carbon	$\frac{1}{2}$
Silicon	26	Chlorine.	$\frac{1}{8}$
Aluminium	$7\frac{1}{2}$	Phosphorus	$\frac{1}{2}$
Iron	$4\frac{1}{2}$	Manganese	$\frac{1}{4}$
Calcium	$3\frac{1}{2}$	Sulphur	$\frac{1}{8}$
Sodium	$2\frac{1}{2}$	Barium	$\frac{1}{33}$
Magnesium	$2\frac{1}{2}$	Fluorine	$\frac{1}{33}$
Potassium	$2\frac{1}{2}$	Nitrogen	$\frac{1}{50}$
Hydrogen	1	Chromium	$\frac{1}{100}$
Titanium	$\frac{1}{2}$	Nickel	$\frac{1}{200}$

The other elements are present in exceedingly small proportions only.

Of the metals, aluminium is by far the most widely distributed, but although of late years the cost of its production has been considerably reduced, it has quite failed to realise the expectations which were at one time formed concerning its value as a material of construction, and there is every reason to believe that iron, which, after aluminium, occurs most plentifully, will continue to occupy the most prominent position in the useful arts.

CHAPTER III.

IRON.

Smelting of Iron Ores.

Iron is met with in commerce as an alloy of the chemical element iron with carbon and other elements. The three varieties of commercial iron, viz., cast iron, wrought iron, and steel, are distinguished from one another chiefly by the amount of carbon they contain. Iron rarely occurs in the free state in nature, but is smelted from various ores found in many parts of the world. In making either iron or steel, the first process is almost invariably the production of pig iron in the blast furnace.

Ores of Iron.—The chief workable ores are :—

(1) *Magnetic iron ore*, or magnetite, Fe_3O_4 , a very pure and rich ore occurring abundantly in Norway and Sweden, and from which the celebrated Dannemora iron is smelted, charcoal being used as fuel.

(2) *Red Hematite*, consisting of anhydrous ferric oxide, Fe_2O_3 , found in the Furness district, and in Spain, Germany, Canada, and the United States.

(3) *Brown Hematite*, a hydrated ferric oxide of the formula $2\text{Fe}_2\text{O}_3 + 3\text{OH}_2$, is probably the most widely distributed ore of iron, occurring in this country in Lincolnshire, Northamptonshire, and the Forest of Dean, and also at Bilbao in Spain, and in France and Germany.

(4) *Spathic iron ore*, clay ironstone, blackband, or Cleveland ironstone, is more or less pure ferrous carbonate, FeCO_3 , and is found in Durham, Yorkshire, Staffordshire, Somerset, Derbyshire, South Wales, and Scotland, and abroad in Germany, Hungary, Carinthia, Russia, etc.

Hence it will be seen that the only ores used on a large scale are impure oxides and carbonates of iron. In the preparatory process of calcining or roasting, which is carried out in large kilns, moisture, volatile or combustible matter, sulphur and

Composition of Common Ores of Iron.

Name of Ore.	Chemical Composition.	Formulas.	Percentage of Iron.	
			Pure Compound.	Ore.
Magnetite . . .	Black Oxide of Iron . . .	Fe_3O_4	72.4	62
Red Hematite . . .	Anhydrous Ferric Oxide	Fe_2O_3	70.0	60
Brown Hematite . . .	Hydrated Ferric Oxide . . .	$2 \text{Fe}_2\text{O}_3 \cdot 3 \text{OH}_2$	59.89	42
Clay Ironstone } Spathic Iron Ore }	Ferrous Carbonate . . .	FeCO_3	48.27	35

carbonic anhydride, CO_2 , are largely expelled, and any ferrous carbonate is reduced to ferric oxide thus:—

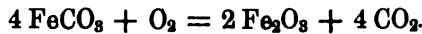

The chemical reaction which takes place in the smelting of iron is consequently very simple, and consists of the reduction of ferric oxide by means of carbonic oxide at a high temperature, thus:—

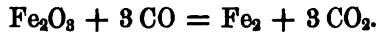

The combustion resulting from the action of the blast upon the lower layers of fuel produces carbonic anhydride, CO_2 , which ascending through the mass of incandescent fuel above, is reduced to carbonic oxide, CO , thus:—

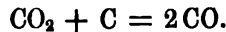

This carbonic oxide then becomes the active reducing agent in the blast furnace. The "gangue" or earthy matter contained in the ore, and the ash left from the combustion of the fuel, must at the same time be got rid of. This is accomplished by adding to the charge a flux, such as limestone, which, at the high temperature of the furnace, produces with the earthy matter a fusible slag consisting of the double silicate of lime and alumina. The slag, being lighter, floats upon the molten metal which collects at the bottom of the furnace, and is allowed to run away continuously during the working of the furnace through a hole or *cinder notch* situated at the proper height.

Blast Furnace.—The form generally given to the blast furnace has been derived from the outline section shown in Fig. 3. It consists of two truncated cones joined together at their bases,

with a smaller cylindrical portion below. The upper conical part is known as the *stack or body*, the lower being termed the *boshes*, and the junction, or widest part, the *belly* of the furnace. The mouth, or opening at the top, is described as the *throat*, and the contracted portion at the bottom, the *hearth*. Near the bottom of the hearth at one side is a rectangular opening, or *tap hole*, closed with a stopping of clay when the furnace is at work. Formerly, the furnace was open-topped, the gas and flame being

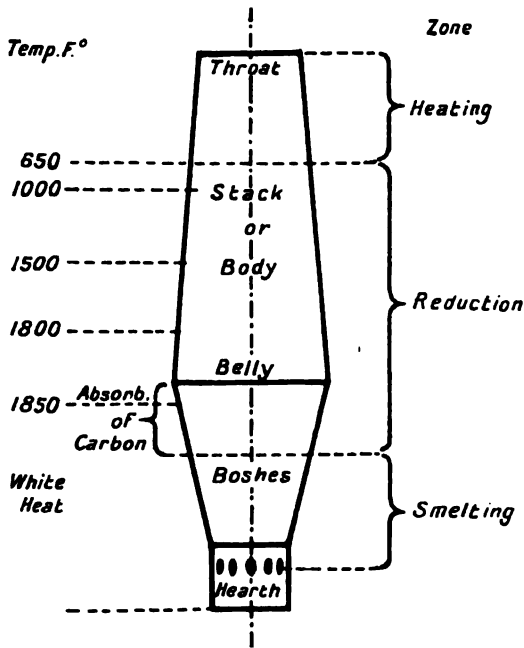

FIG. 3.—Profile of Blast Furnace.

allowed to escape directly into the atmosphere, resulting in a great loss of heat. Since the introduction of hot blast working by Neilson in 1828, some arrangement for closing the throat has always been employed, the waste gases being drawn off and utilised by burning in stoves for heating the blast blown into the furnace, or under steam boilers for raising steam, and more recently, in working large gas engines for supplying the blast.

“Cold Blast” Iron.—A high grade pig iron for special foundry purposes, or for conversion into best Yorkshire iron, as will be

subsequently explained, is still smelted with cold blast at a few ironworks.

Originally, the furnace was built of solid masonry, and even

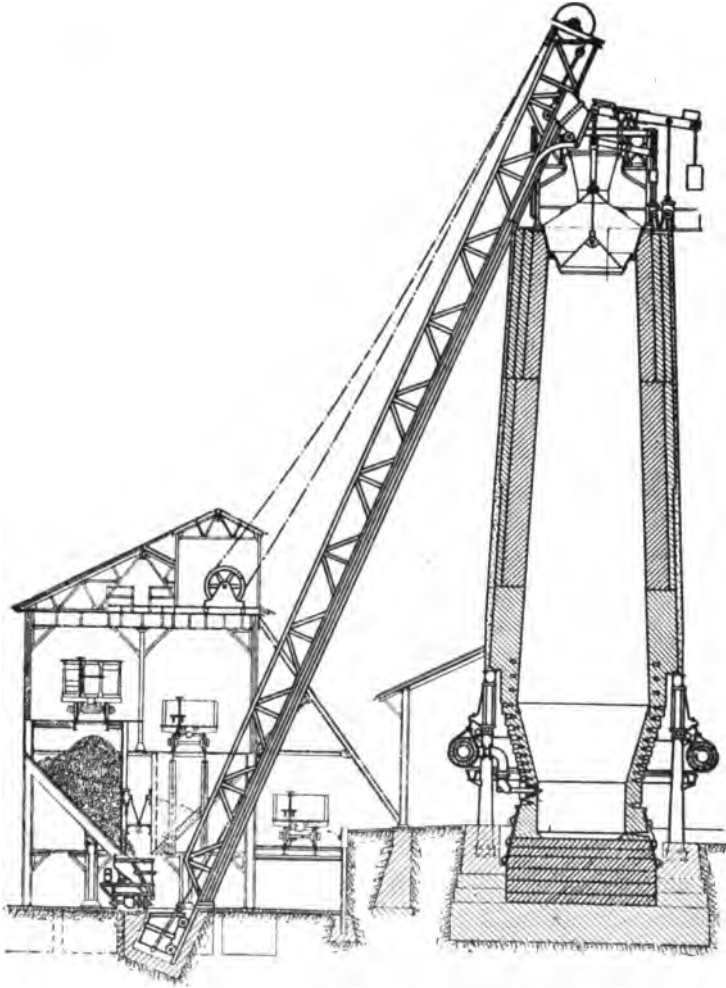

FIG. 4.—Section of Blast Furnace.

when iron-cased, had a double lining, the outer one of common brick, and the inner of firebrick, a narrow space filled with ashes being left between. This was done to prevent loss of heat, and to allow for expansion and contraction in working. It has been

found that the loss of heat has no serious consequences, and that on the other hand, the necessity for repairs is diminished by permitting reasonable cooling action. Hence the modern furnace (Fig. 4) is completely cased with steel plates, and only one lining of firebrick is employed.

The stack is carried upon a ring girder resting on steel columns, which in recent designs have been much increased in height, leaving the lower part open to facilitate cooling of the boshes. The hearth is built as an independent portion of the structure, after the stack has been completed.

On the Continent and in America, the iron casing has been abandoned, and the thickness of the lining has been so far reduced that it has become necessary to erect a lattice work tower round the furnace to carry the weight of the charging gallery, the inclined transporter for raising the charge, and the "down comer" for the waste gases. In this case, brackets from the tower, instead of steel columns, are used to support the ring upon which the stack is built, giving very free access round the hearth. The latest practice in furnaces which are to be driven hard, is to build the boshes of cast iron cooling blocks through which water is caused to circulate (see Fig. 5), and which are provided with a very thin lining of refractory brickwork.

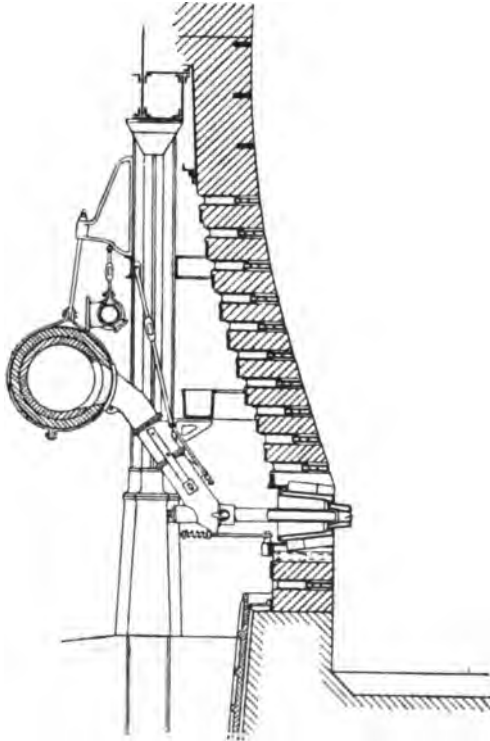
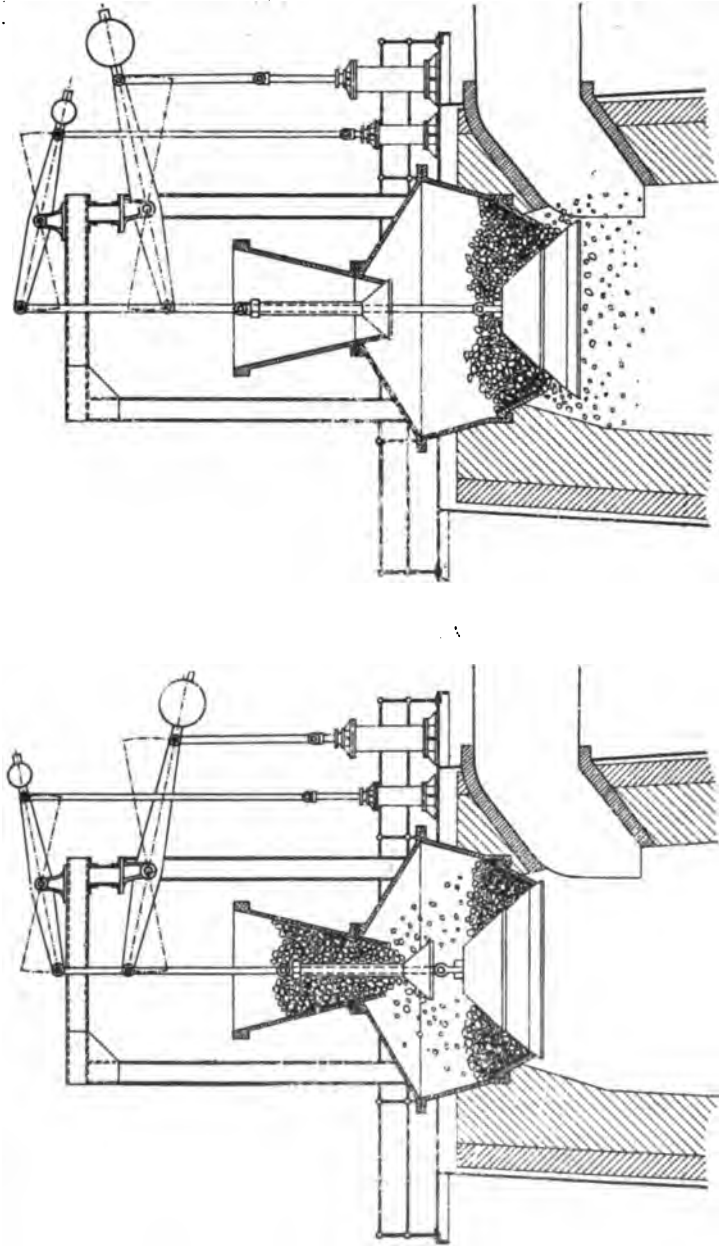

FIG. 5.—Boshes and Tuyere of Blast Furnace.

The latest practice in furnaces which are to be driven hard, is to build the boshes of cast iron cooling blocks through which water is caused to circulate (see Fig. 5), and which are provided with a very thin lining of refractory brickwork.



(a) (b)
FIG. 6.—“Cup and Cone” Charging Arrangement for Blast Furnace.

Some modification of the *cup and cone* arrangement (see Fig. 4) is now invariably used for closing the throat, the gases passing through an opening in the side above the level of the charge into a vertical pipe or *downcomer* leading to the hot-blast stoves. The cup is in the form of a hopper or funnel-shaped casting built into the mouth of the furnace. The cone or bell is suspended from a counterbalance lever, so as to project somewhat below the bottom of the cup. When closed, the arrangement practically becomes a hopper, into which the charge of ore, fuel, and limestone is deposited. Where hand feeding is adopted, the cone is lowered by means of a hand wheel operating a pinion which gears into a toothed sector on the end of the lever, or it may be allowed to fall by the weight of the charge by opening the cock controlling a hydraulic cataract cylinder. The material thus charged into the furnace is distributed uniformly round the circumference, and the counterbalance weight at the end of the lever then comes into play, bringing the cone back against the seat at the bottom of the cup. In some recent examples two cones are employed (Fig. 6) to avoid loss of gas during the interval when charging takes place. With the smaller bell closed, the charge is introduced into the inner cone. On lowering the smaller bell (Fig. 6 (a)), the charge is deposited in the space between the cup and the larger cone. The smaller bell is again raised, to prevent the escape of gas, and the material charged into the furnace as above described by lowering the main cone (Fig 6 (b)). The *blast main* is connected to the *horseshoe main*, which is a large pipe in the form of a horizontal ring almost entirely encircling the furnace, and carried by brackets on the columns which support the stack. From it, smaller pipes or *goose-necks* lead to the air nozzles or *tuyeres* (Fig. 5), through which the blast enters the furnace. The tuyeres are usually eight or ten in number, arranged at equal distances round the circumference of the hearth. Being exposed to an extremely high temperature, and also to the destructive influences of molten metal and slag, they must be *water-cooled*. For this purpose, the nozzle is made in the form of a hollow cone of wrought iron or phosphor-bronze, through which a constant stream of water circulates.

Hot-Blast.—The use of hot instead of cold blast has not only effected a great saving in fuel, but has also rendered possible a considerable increase in the “make” per furnace. The

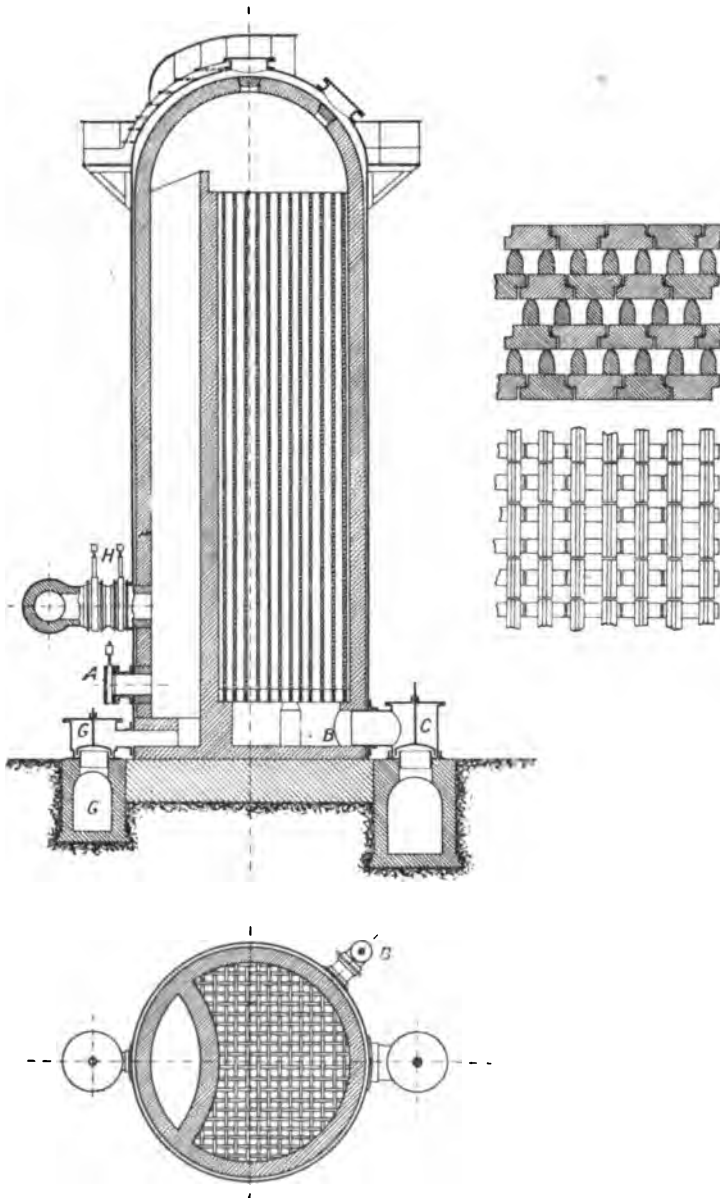

FIG. 7.—“Cowper” Hot-Blast Stove.

temperature of the blast now reaches 1,300° or 1,400° F., or a visible red heat, which is obtained in *regenerative firebrick stores*, the best known and most widely adopted arrangement being that of Cowper, shown in section in Fig. 7. The *Cowper stove* consists of an outer casing of steel plates, about 20 to 25 feet diameter and from 50 to 80 feet high, having a dome-shaped top, and lined internally with firebrick. At one side of this casing, a firebrick flame flue is built up almost to the top, the remaining space being filled with a honeycomb structure of firebrick "chequer work" for absorbing the heat. Firebricks of special shape are frequently used, as shown in the detail on the right, to expose rounded surfaces and prevent clogging up with dust. When the stove is "on gas," the blast furnace gas and the air necessary for its combustion are admitted through valves G and A respectively, at the bottom of the flame flue. The three valves G, A, and C being open, an immense volume of flame ascends through the flame flue, and is deflected by the dome through the interstices of the chequer work, passing slowly through the mass of firebrick, which thus becomes incandescent, the products of combustion escaping to the chimney flue through the valve C. To place the stove "on blast" the gas valve, the air valve, and the chimney valve are closed, the cold air valve B at the bottom of the regenerator, and the hot blast valve H at the bottom of the flame flue are opened. The cold air supplied by the blowing engine now enters the regenerator through the valve B, and taking up the heat from the incandescent brickwork has its temperature raised to about 1,500° F. before passing away to the hot blast main and thence to the tuyeres of the blast furnace. The stoves are in pairs, and are worked alternately, one being heated by the combustion of the furnace gases, whilst cold air is being sent through the other. The reversal takes place at intervals of about half an hour, and is effected by means of suitable valves.

One of these stoves containing as much as 1,000 tons of firebrick, and having about 80,000 square feet of heating surface, will supply 16,000 cubic feet of blast per minute. Cleaning is effected by discharging a small gun a few times in succession at the top and bottom of the stove. The fine dust which is brought over in the gases from the furnace, and which is gradually deposited in the passages of the regenerator, is then thrown down

by vibration to the bottom of the stove, and may be removed through suitable doors.

Formerly, two stoves were used for each furnace, but for the rapid driving now in vogue three or four stoves per furnace are required. To each furnace a dust catcher is generally applied. This consists of a cylindrical casing about 20 feet diameter and 40 feet high with a conical bottom, lined throughout with fire-brick, and having an arrangement of internal cones and baffle plates to effect a sudden change in the direction of flow of the gas. This causes the particles of dust to fall down to the bottom of the hopper, in which there is a dust outlet valve of bell type communicating with a telescope tube, so that the dust may be discharged directly into wagons.

Blast Engines are usually of the vertical direct-acting type, and the air or blowing cylinder of 80 to 100 inches diameter is placed vertically below the steam cylinder, which has a diameter of 36 to 44 inches, the stroke being about 5 feet. The arrangement is clearly shown in Fig. 8, which represents an engine of this type constructed by the Lilleshall Co., Ltd., of Oakengates, Shropshire. The steam and air pistons are on one rod, and from the crosshead, motion is taken by connecting rod to the crank-shaft, the latter being arranged to carry a heavy fly wheel on each side of the engine.

In the covers or heads of the blowing cylinder, flap valves of leather, or disc valves of indiarubber are fitted, one set for suction and another for delivery at each end of the cylinder. Flat gridiron valves mechanically operated by suitable gear from the main shaft have also been employed.

Compound engines are occasionally used, but as a rule preference is given to the single-cylinder type on the score of simplicity and reliability. This is of paramount importance, as a blowing engine is required to work continuously day and night for a long period. Internal combustion engines, working directly with waste gas from the blast furnaces, have recently been adopted with success; in some instances, however, they have not proved uniformly reliable, and trouble has been experienced with the dust and impurities in the gases, necessitating frequent stoppage for cleaning, etc. A method promising good results would seem to be the utilisation of the exhaust steam from steam engines by low pressure turbines generating electric current at



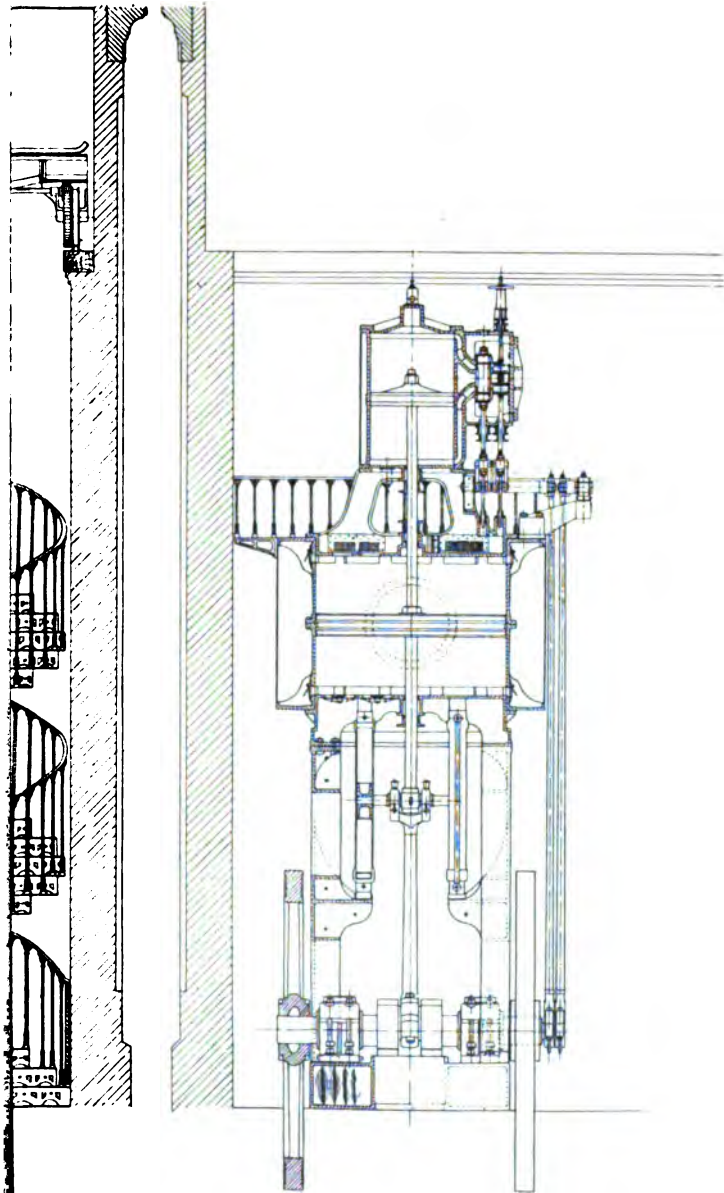

ng Engine.

[To face p. 24.]

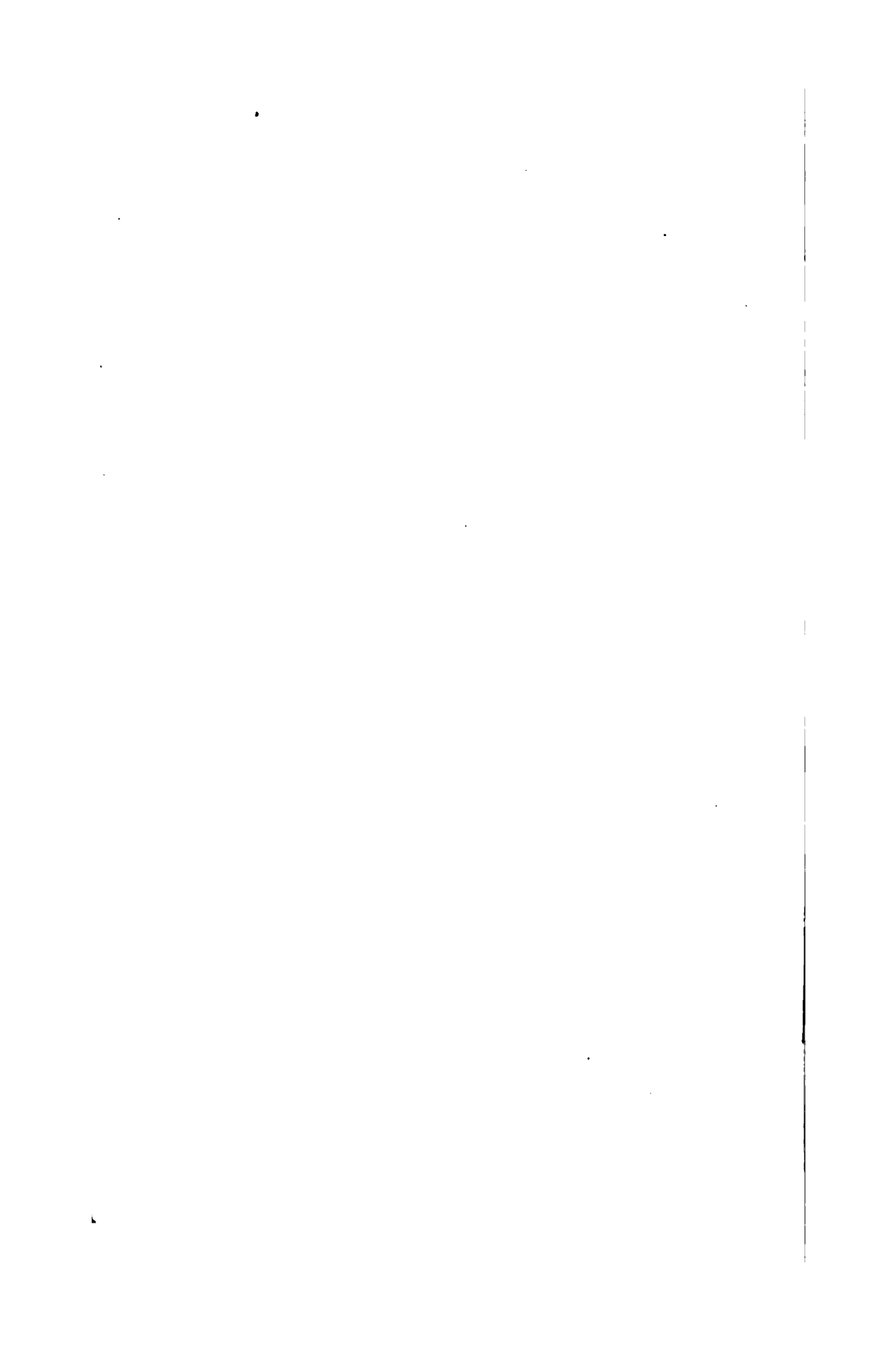

high voltage for distribution throughout the works. It has been estimated that at least 1,000 h.p. from each furnace in blast might be made available in this way.

Formerly, all the furnaces were blown from one set of engines

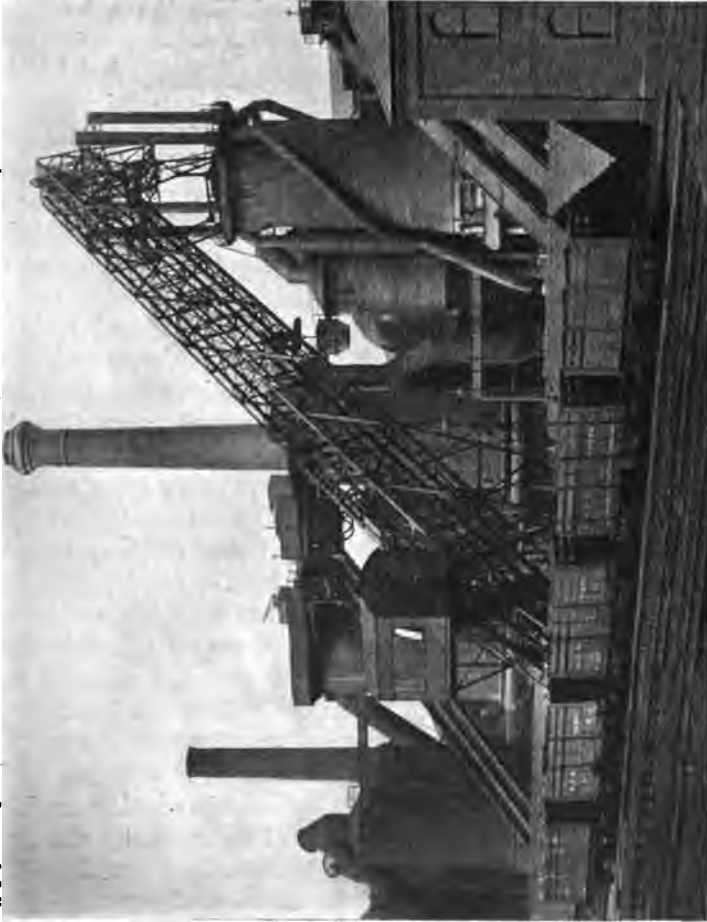

FIG. 9.—The Aumond Blast Furnace Charger, Barrow Steel Works.

on the same main. According to recent practice, one blowing engine is provided for each furnace, and further, each furnace may have its own blast main, so arranged that any engine may be used for any furnace. Depending upon the height of furnace and rate of working, the blast pressure varies from $3\frac{1}{2}$ to 7 lbs.

per square inch in ordinary practice, up to 12 or even 20 lbs. per square inch on the American plan, and each engine may have a capacity of from 20,000 to 30,000 cubic feet per minute.

Air and Gas Mains.—The cold blast main is usually about 18 inches diameter, but it is necessary to increase the size of the hot blast main from the stoves to the furnace on account of the high temperature, and an outside diameter of from 3 to 4 feet is not uncommon, the pipe being lined with 9-inch thickness of firebrick. The gas main from the dust catcher has a diameter of 6 or 7 feet, and is lined with $4\frac{1}{2}$ -inch brickwork. It is provided with expansion joints at every 10 or 12 yards, and frequently a bell and hopper arrangement, with a telescopic chute below for the removal of dust, is fixed at intervals of 6 yards.

Lifts and Elevators.—The charge of ore, flux, and fuel is raised to the top of the furnace sometimes by perpendicular lifts (Fig. 10), but now more usually by an inclined hoist (Fig. 4). With the increased output demanded in recent years, the old method of charging by means of hand-barrows has become obsolete, and when it is considered that for every 1,000 tons of iron produced, some 3,500 tons of material must be charged into the furnace, it will be readily understood that some system of automatic charging becomes indispensable. In the skip or bucket system, the ore and fuel in proper proportions are tipped into tubs or skips, each of which can hold about 120 cubic feet. Fig. 9 shows the Aumond charger erected at the works of the Barrow Hematite Steel Co., Ltd., Barrow-in-Furness, by the firm of Demag, of Duisburg, Germany. The skips are run up an inclined plane or skipway inclined at about 70° with the horizontal, by means of steam power, or an electric winding engine. Arrived at the top, the skip, which is of cylindrical form, and provided with a cone-shaped drop bottom, is lowered bodily into the furnace mouth and the bottom dropped automatically, thus allowing the charge to slide evenly into the furnace. A self-acting arrangement is provided at the top and bottom of the lift to prevent over-winding, and to bring the empty skip quietly to rest at the bottom. No workmen are required at the furnace top, except for oiling or repairs.

The Charge.—The relative proportion of the materials com-

posing the charge varies with the nature of the ore and of the fuel, and also of the pig-iron to be produced. With red hematite, 40 cwts. of ore, 20 cwts. of coke, and 8 cwts. of limestone are required to make 1 ton of pig iron. With clay ironstone, 48 cwts. of calcined ore, 20 cwts. of coke, and 12 cwts. of limestone are necessary for the production of 1 ton of grey foundry pig. The coke should be hard and compact, and able to resist crushing, and it is important that it should be free from sulphur. The ore, fuel, and limestone, are each weighed out separately, and the charge is introduced into the furnace in layers so as to keep a fairly constant level at what is known as the *stock line*. When in full blast, the bell is lowered every ten or fifteen minutes to admit a fresh charge. From eight to forty-eight hours is occupied by the material in making the complete descent of the furnace, depending on the nature of the ore and the quality of the iron produced. The *make or yield* of a furnace is usually 400 or 500 tons per week, but with larger furnaces and the modern system of hard driving, an output of from 1,500 to 2,000 tons per week has been reached.

Working of the Furnace.—A modern blast furnace plant, erected at the Redbourne Hill Iron and Coal Co.'s Works, Frodingham, Lincolnshire, by Messrs. Head, Wrightson & Co., Ltd., of Thornaby-on-Tees, and embodying the features already alluded to, is shown in the photograph, Fig. 10. The molten metal is allowed to accumulate until the hearth is full, and the furnace is *tapped* at intervals of from six to twelve hours, by driving an iron bar through the clay stopping of the tap hole, the blast being turned off meanwhile. The metal then flows along a channel to the *sand or pig bed*, clearly seen in the figure, which has a gradual slope from the furnace. Leading from the main channel at right angles are formed a number of lateral branches or feeders, termed *sows*, from each of which again runs a series of parallel furrows of semi-cylindrical section, known as *pigs*. The molten metal is allowed to run into the lowest sow first, and then into each of the others in succession, the stream being deflected in the proper direction by means of *stops* of sand placed against a spade driven down into the channel where required. When all the metal has been run off from the hearth, the tapping hole is "stopped," and the blast again turned on. As soon as solidification has taken place, the pigs, which are about 8 feet long and 3 or 4 inches

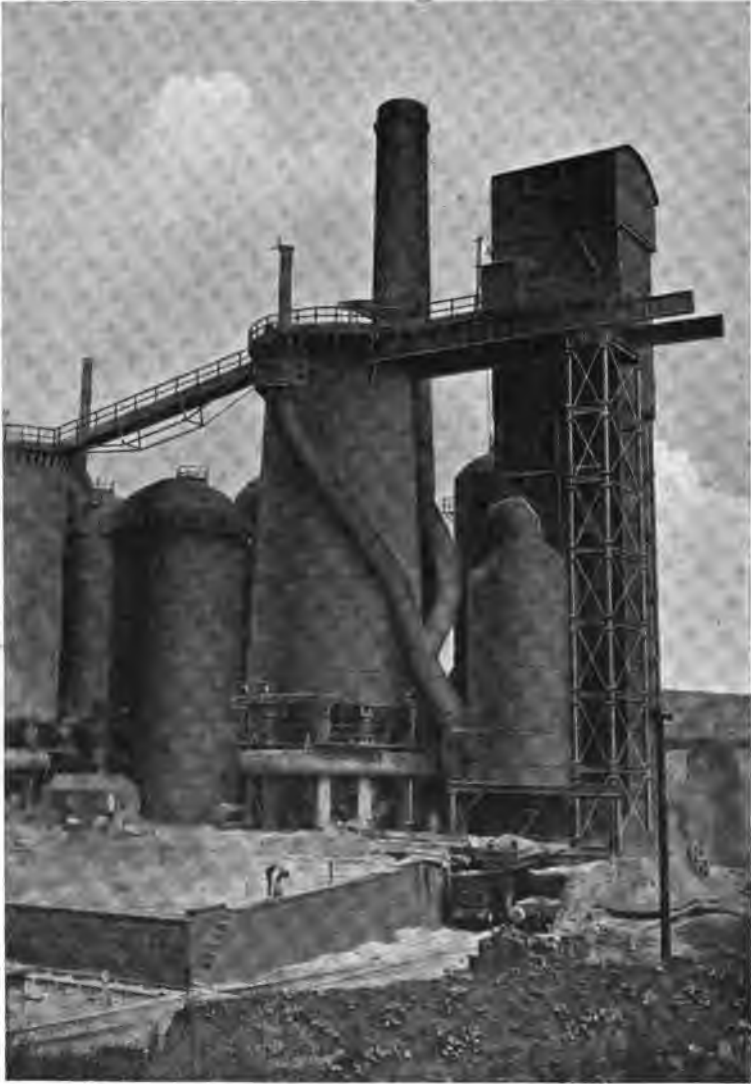

FIG. 10.—Blast Furnace Plant at Redbourne Hill Ironworks, Lincolnshire.

wide, are broken off with a heavy hammer and removed by manual labour. Pig iron casting machines are also in use, in which iron moulds carried on an endless chain are caused to move slowly past the mouth of the channel leading from the

tapping hole. The metal solidifies during the passage, which occupies about ten minutes, and is turned out of the mould into a truck as the chain commences its return journey. If intended for subsequent conversion into steel, the iron is not cast into pigs, but is run into a ladle carried on a bogie, on which it is transported to a *metal mixer*, to be distributed to the Bessemer converters or steel furnaces as required.

Slag.—The slag is allowed to run continuously from the furnace, either into small iron wagons or *slag tubs*, see Fig. 10, or into water. In the former case, it solidifies into blocks in a convenient form for transport to the tip or *cinder heap*. Sudden cooling in water reduces slag to the condition of coarse sand, which has been used for making bricks or concrete. Many attempts, more or less successful, have been made to utilise slag in the form of road metal, railway ballast, paving blocks, etc., or for the manufacture of Portland cement. The quantity produced, amounting to from 10 to 30 cwts. for every ton of iron made, is, however, so enormous, that its general utilisation would appear to be an exceedingly difficult matter.

Blast Furnace Gas.—This is always utilised to a greater or less extent, but the quantity produced is truly enormous, amounting to from 5 or 6 tons in weight for each ton of pig iron made. About 80 per cent. by volume of the gas is combustible, the average composition at the throat of the furnace when fired with coke being as follows:—

	Per cent. by volume.
Nitrogen	58
Carbonic oxide	28
Carbonic acid gas	11
Hydrogen	2
Marsh gas	1

A comparatively small portion of the gas, probably not more than 14 per cent., is used for heating the blast, and occasionally a further quantity for steam raising. There is, however, much more than is needed for these and similar purposes, and it is not surprising that after every requirement of the ironworks and even the collieries in connection has been satisfied, proposals should have been made with the object of utilising the large quantity remaining, for the purpose of supplying, by means of

large gas engines, electric light and power to the district adjoining. It is safe to say that not less than 25 per cent. of the total heat developed in the average blast furnace, which represents about 10,000 horse-power, might be made available in this way.

CHAPTER IV.

PIG IRON.

Pig Iron may be described as a compound of iron with carbon, silicon, sulphur, phosphorus, and manganese. The essential feature is the presence of from 2 to $4\frac{1}{2}$ per cent. of carbon, which exists in two distinct forms, partly in solution or *combined*, and partly distributed throughout the mass in the form of *graphitic*, or *uncombined*, carbon. According to the relative proportion of



FIG. 11.—Fractures of Pig Iron.

the two forms present, cast iron is classed in three varieties, *grey*, *mottled*, and *white* (Fig. 11). In commerce, pig iron is usually distinguished by numbers, ranging from 1 to 6, or even 8, the highest number being the cheapest. There is, unfortunately, no standard in use by means of which the various grades may be determined, the colour and general appearance of the fractured surface being the only guide.

No. 1 *pig iron* shows a highly crystalline fracture, the crystals being large and evenly distributed. It is very dark grey in colour, due to the large, lustrous flakes of graphite which are easily distinguishable on the fractured surface with the naked eye. The carbon, usually about 3 to 3½ per cent., is therefore almost entirely in the graphitic or uncombined form, the combined carbon not exceeding 0·3 per cent. The iron is very fluid when melted, and makes very fine and sharp castings suitable for ornamental work. The pig emits a dull leaden sound when broken, denoting a deficiency in strength and hardness. Unless mixed with scrap, or with other numbers, it is not suitable for engineers' castings.

No. 2 is lighter in colour, and is harder and stronger than No. 1, but does not run so fluid when melted. The combined carbon does not exceed 0·4 per cent.

No. 3 is again lighter in colour, due to the fact that the graphite is present in much smaller flakes, not readily distinguishable, and the crystals are also smaller, the fracture being smoother, more regular and compact. The carbon content is less than Nos. 1 and 2, the amount combined not exceeding about 0·6 per cent., and the metal is less fluid when melted, but it possesses much greater tenacity and hardness. It is, therefore, the most extensively used for foundry purposes.

No. 4 is still lighter in colour, and of finer grain. The flakes of graphite are scarcely discernible, and the combined carbon is now equal to 0·9 per cent. It possesses great tenacity and hardness, and can only be used alone for rough castings which do not require machining, but it is useful for mixing with lower numbers. There are two varieties of No. 4, described as No. 4 foundry and No. 4 forge respectively. The latter is almost white in colour, and is too hard for foundry work, being used solely for conversion into wrought iron in the puddling furnace.

Nos. 1 to 4 are classified as "*grey*" irons, and are the only grades in regular demand for foundry purposes.

No. 5 is known as "*mottled*" iron, its fracture resembling a matrix of white iron interspersed with spots of grey. The carbon is contained in both the free and uncombined forms, and in very nearly equal proportions. For castings of exceptional hardness, as required for engine cylinders, a small quantity of mottled iron may be added to the mixture.

No. 6 is "white" iron, which is extremely hard and brittle. The fracture is close-grained, and is almost devoid of separated graphite. The carbon is almost entirely combined, only a trace being present in the form of graphite. It melts at a lower temperature than grey iron, but before fusion, passes through a viscous or pasty condition, of which advantage is taken in the puddling process. It does not become sufficiently fluid to cast well, and is totally unsuitable for the foundry, being used only for the production of wrought iron. All grades above No. 6 are distinctly forge pigs.

Typical Analyses of Pig Iron.

Constituent.	Grey.					Mottled.	White.
	No. 1.	No. 2.	No. 3.	No. 4 Foundry.	No. 4 Forge.		
Graphitic Carbon	3.50	3.35	3.20	3.00	2.85	1.90	Nil.
Combined Carbon	0.15	0.20	0.25	0.30	0.35	1.35	3.10
Total Carbon .	3.65	3.55	3.45	3.30	3.20	3.25	3.10
Silicon .	2.85	2.60	2.40	2.10	1.75	1.10	0.96
Manganese .	1.30	1.25	1.20	1.10	1.05	0.65	0.50
Sulphur .	0.03	0.04	0.04	0.04	0.05	0.20	0.30
Phosphorus .	0.60	0.65	0.70	0.80	0.90	0.95	0.90
Iron	91.57	91.91	92.21	92.66	93.05	93.85	94.24

It will be noticed that the combined carbon increases as the numbers rise, the graphitic decreasing in a corresponding ratio. Silicon diminishes from No. 1 grey to white, the usual proportion for foundry purposes being from 2 to 2½ per cent. Manganese, sulphur, and phosphorus remain fairly constant throughout the grey numbers, the two latter showing some tendency to rise. These gradations in chemical composition are, however, not always regular, and may vary from time to time for the same brand.

Impurities in Pig Iron.—Carbon and silicon may be looked upon as essential constituents of pig iron, and are usually present

to a considerable extent, whereas manganese, sulphur, phosphorus and occasionally other elements occur in very small proportions, and are, strictly speaking, impurities, imparting more or less undesirable properties.

Silicon is almost invariably present, in quantity varying from about 1 per cent. as a minimum to as much as 3·5 per cent. or even more. The introduction of silicon in small quantities has a tendency to transform the combined into graphitic carbon, rendering the metal softer. On the other hand, with from 5 to 10 per cent. of silicon, the iron becomes extremely hard and brittle, breaking with a glass-like fracture, from which the name of *glazy pig* is derived. Silicon also tends to reduce the absorption of sulphur by pig iron. Hence white iron, which contains much less silicon than grey iron, has usually a larger percentage of sulphur.

Sulphur appears to act in exactly the opposite manner to silicon, converting the carbon into the combined condition, and rendering the metal white, hard, and brittle. A very small proportion of sulphur, as low perhaps as 0·05 per cent., will cause the iron to be quite unsuitable for subsequent conversion into steel. The quantity of sulphur present in pig iron does not often exceed 0·15 per cent., but its presence makes the metal flow sluggishly when melted.

Phosphorus is nearly always found in pig iron, in amount varying from a trace up to 2 or 3 per cent. It increases the fluidity of the metal, and for fine castings where strength is not the primary consideration, its presence in moderate amount, up to about 1·0 per cent. is decidedly advantageous. With proportions exceeding 0·5 per cent. the tensile strength of the iron is reduced.

Manganese, by increasing the power of the iron to combine with carbon, tends to make pig iron white and brittle. Its presence assists in getting rid of sulphur, or rather in preventing the sulphur present from passing into the iron. Two varieties of pig iron very rich in manganese are manufactured for use in steel making. One containing from 10 to 25 per cent. of manganese is known as *spiegelisen*, and the other containing 70 to 80 per cent. of manganese together with 6 or 7 per cent. of carbon, is termed *ferromanganese*.

CHAPTER V.

WROUGHT IRON.

The Production of Wrought or Malleable Iron.—The only process of any importance in use at the present time for the production of wrought iron is known as the *indirect* method, because pig iron must first be obtained by smelting iron ore in the blast furnace, and has then to be decarburised in the *puddling furnace* to effect its conversion into wrought iron. Pig iron for this purpose is first subjected to a preliminary process of *refining*, the object being to effect as completely as possible the removal of the silicon, together with the greater part of the phosphorus, and to convert the graphitic into combined carbon. In this way, the grey iron is first converted into white, the latter alone being suitable for use in puddling. White iron when near its melting temperature assumes a pasty condition, which readily permits the oxidising action of the oxygen of the air to take place. Grey pig iron in melting passes at once from the solid to the liquid state, and when fluid, is immediately covered with slag, which, floating upon the surface, effectually prevents the oxidising influence of the blast being felt. The removal of the carbon by oxidation cannot therefore take place until the graphitic has been converted into combined carbon, or until the grey iron has been transformed into white. At the works producing “*best Yorkshire iron*,” of which Low Moor is the best known, great importance is attached to the refining process. The author is indebted to Mr. H. B. Woodcock, forge manager, Low Moor Ironworks, for the drawings and photographs of the refinery and puddling furnace here presented. The refinery, shown in the drawing, Fig. 12, and in the photograph, Fig. 13, consists of a rectangular *hearth* about 4 feet square and 18 inches deep, three sides of which are formed of water-cooled cast iron boxes *a*, the front being an iron *dam-plate b*, through which the *tap-hole c* passes. The bottom of the hearth consists of a layer of sand about 12 inches thick. A framework of cast iron *d*, supports a low

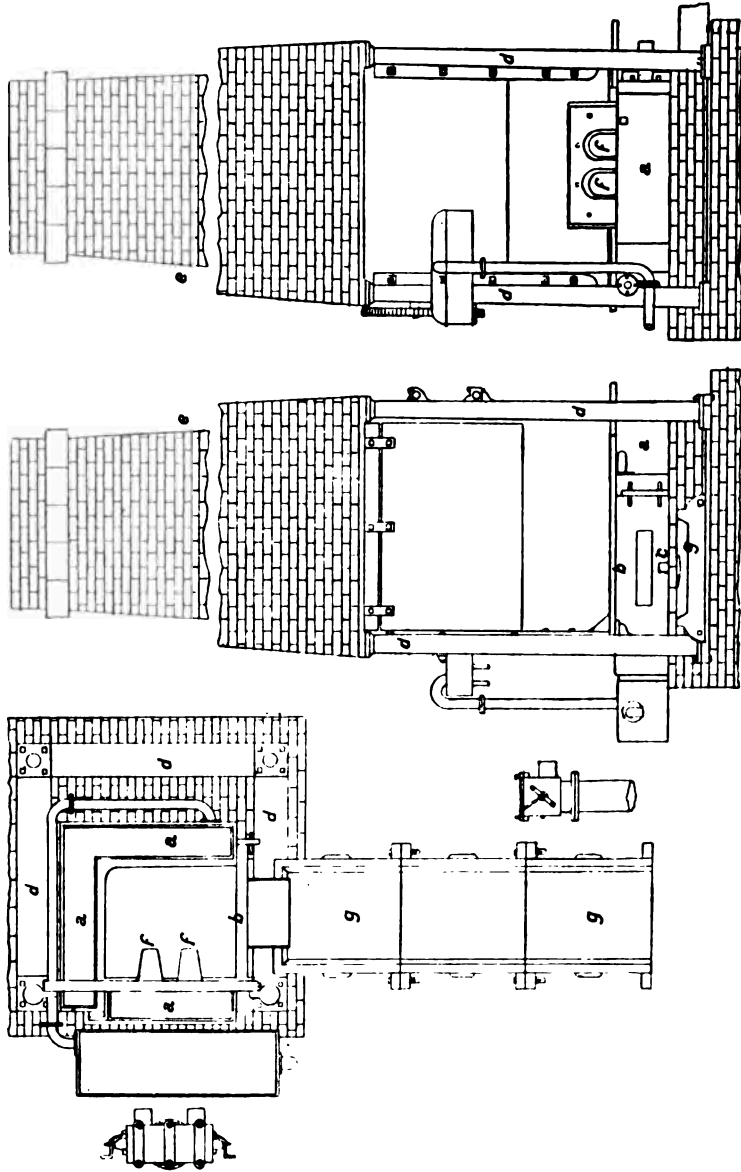

FIG. 12.—Refinery, Low Moor Ironworks.

brick chimney *e*, 16 feet high, immediately over the hearth, and also serves to carry two water-cooled tuyeres, *f, f*, of $1\frac{3}{4}$ inches diameter, placed on one side of the fire and inclined downwards



FIG. 13.—Refinery, Low Moor Ironworks.

at an angle of 30° . The blast is supplied at a pressure of about 2 lbs. per square inch, and is directed upon the surface of the molten metal so as to produce a constant oxidising action. A coke fire having been lighted and the blast turned on, the charge of about 80 cwts. of pig iron is put on in layers alternating

with coke. More fuel is piled all round and on the top, and the full blast allowed to act from one and a half to two hours. When the operation is judged to be complete, both metal and slag are tapped out into a long cast iron trough, or *pig-mould g*, about 2 feet wide by 6 feet long. The slag, which is very rich in iron, floats upon the surface, and is run off into moulds, leaving a plate of metal about $3\frac{1}{2}$ inches thick, upon which water is sprayed to facilitate rapid cooling. The slab thus becomes very brittle, and is easily broken into pieces of suitable size for introduction into the puddling furnace. The slab on being broken exhibits a bright silvery-white fracture and is known as refined iron. The most striking feature is the almost entire removal of the silicon, as shown by the following:—

Analyses of the Original Cold Blast Pig Iron and the Refined Metal produced from it.

Constituent.	In Original Pig.	In Refined Iron.
Carbon—graphitic . . .	2.90 per cent.	—
Carbon—combined . . .	0.60 "	3.50 per cent.
Silicon	1.50 "	0.30 "
Sulphur	0.20 "	0.05 "
Phosphorus	0.50 "	0.13 "
Manganese	0.50 "	—

Puddling is in reality a continuation of the operations occurring in the refinery, carried out upon the hearth of a reverberatory furnace, the object being to permit the use of coal or coke as fuel by burning it out of contact with the iron. In this way the possibility that sulphur, which is almost always present in the fuel, may find its way into the finished product is largely avoided. The original process introduced by Henry Cort in 1784, and still employed at the Low Moor Works, makes use of white iron, which, as already noted, does not become actually fluid. The method, which depends entirely upon the oxidising effect of the oxygen of the air, is, therefore, known as *dry puddling*, in contradistinction to the process of *wet puddling* or *pig-boiling*, in which grey unrefined iron is melted in contact with materials rich in oxygen, such as hematite, forge scale, oxide of iron, etc., and which

themselves supply the oxygen necessary for decarbonisation. The *puddling furnace*, Figs. 14 and 15, consists of two distinct

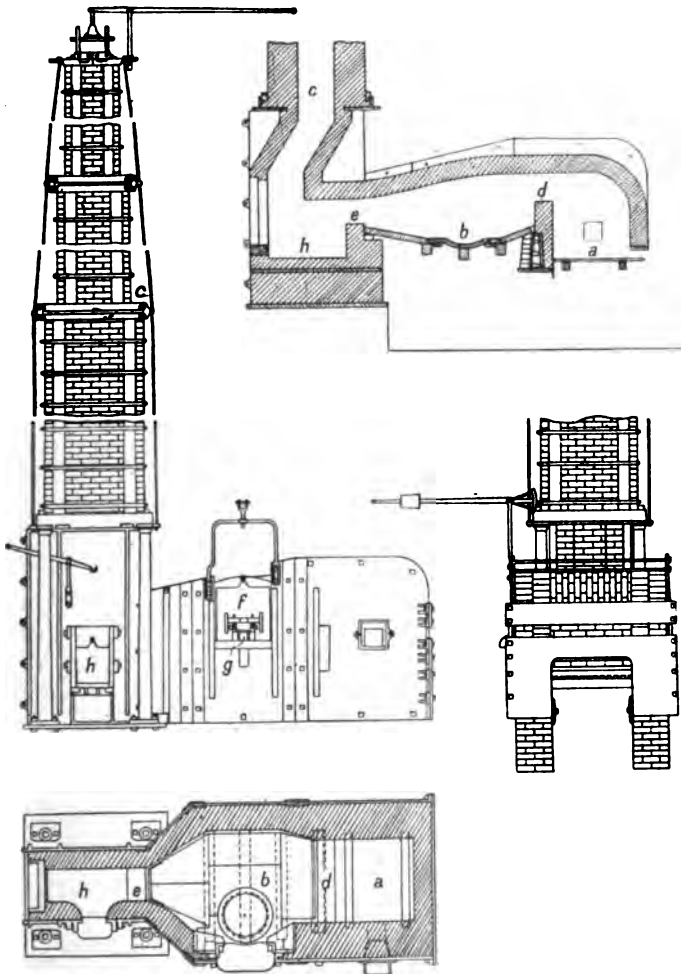

FIG. 14.—Puddling Furnace, Low Moor Ironworks.

parts, the *fireplace* or grate *a*, and the *working hearth* *b*, with a low flat arched roof covering both, and sloping down towards the flue leading into the chimney or *stack* *c*, which has a height of about 40 feet. A damper at the top of the stack, operated by

lever and chain, is provided for the purpose of adjusting the draught as may be required during the working of the furnace. The furnace is built entirely of firebrick, the walls being



FIG. 15.—Puddling Furnace, Low Moor Ironworks.

encased with cast iron plates, or *buckstaves*, secured together with tie rods. The hearth is about 6 feet long, and 3 feet 6 inches wide, tapered towards the ends. The bottom is in the form of a tray, and consists of cast iron plates arranged so as to afford

a free circulation of air beneath and around them. The fire and flue bridges *d* and *e* respectively are hollow cast iron bars encased in firebrick and kept cool by air circulating through them. The *working door f* in front, constructed of firebrick in an iron frame,



FIG. 16.—Shingling Hammer.

is suspended by a chain from the end of a counterbalanced lever, and is only opened when the charge is introduced, or the puddled ball withdrawn. The stirring and working of the charge is effected by means of a long iron rod or *rabble*, inserted through the *stopper-hole g*, in the bottom of the door. The working *bed*

or *furnace bottom* was formerly a lining of sand, but it is now usual to employ a covering of oxide of iron or hammer scale about $1\frac{1}{2}$ inches in thickness. The charge of refined iron, weighing about 3 cwts., is first placed in a heating chamber at the chimney end of the furnace, known as the *dandy, h*, and when red hot is removed to the hearth, where it is ranged round the sides, leaving the centre open. After about twenty-five minutes the metal begins to soften, and when in a pasty condition, it is drawn towards the centre and is stirred or rabbled continuously for about an hour. During this time the carbon and other impurities are oxidised by being brought constantly into contact with the oxygen of the air, the carbonic oxide liberated burning in jets of blue flame known as "puddler's candles." At this stage, the slag begins to sink or "drop," and granules of malleable iron in the form of bright spots gradually increasing in size appear on the surface of the metal as it "comes to nature." The *balling up* of the charge then commences by working together the spongy mass of malleable iron and collecting it into three or four *puddled balls* weighing from 90 to 100 lbs. each. The puddled ball is a spongy mass of malleable iron, the pores of which are filled with slag. It is therefore removed on an iron bogie to the *shingling hammer*, Fig. 16, which expels the slag or shingle, and welds the particles of iron together into a puddled bloom or *noblin* 10 or 12 inches square and about 2 inches thick. These are broken, and the fracture examined, the slabs being classified according to the purpose for which they are to be utilised. For bars, the harder and more crystalline varieties are chosen, whilst for rivets, plates, etc., softer and more fibrous slabs are selected. The noblins are piled one on the other not exceeding four high, and are re-heated and welded under the steam hammer into rectangular billets, which are re-heated and rolled down into bars or plates.

At Low Moor, for making chain or rivet iron, the noblins are taken to the re-heating furnace, heated and hammered twice, and rolled down in the mill into faggots, which are then cut into convenient lengths for re-piling. The piles so obtained are again raised to a welding heat, and hammered twice or three times, and finally rolled into bars of the required size. Exactly the same process is applied in slab making for boiler plates, with the exception that the faggots are cross piled, so that the grain

of the iron may run fairly equally in both directions of the finished plate.

The "best Yorkshire" ironworks—viz., Low Moor, Farnley, Monkbridge, and Taylor's,—produce one variety only, the greatest care being taken to maintain a constantly uniform quality. In Staffordshire and other ironmaking centres, several grades are turned out from the same works, of which the commonest, known as "crown" or merchant, is once piled and re-heated. This is followed by "best," which has received an additional piling and re-heating, "best best" which has been twice so treated, and "treble best," which has undergone the process three times. The repeated hammering, rolling, and working of wrought iron much increases its strength and ductility, and



FIG. 17.—Fracture of Low Moor Iron, showing "fibre."

develops its fibrous character. It is true that the *fibre*, Fig. 17, is due to the presence of slag which has not been completely expelled during the shingling process, and which is subsequently broken up and distributed throughout the iron in the form of innumerable fine filaments running in the direction of rolling. Fibre cannot be regarded as an indication of strength, being due to the presence of a substance weaker than iron. It may, however, be asserted that fibre does denote quality, because it affords evidence that the iron has been worked to such an extent as to distribute the slag uniformly throughout the metal. In this sense a rod of wrought iron may be likened to a bundle of exceedingly fine wires which have been welded together, the small interstices being partially filled with slag. It is frequently asserted that wrought iron will withstand corrosive action due to atmospheric influences, etc., for a greater length of time than

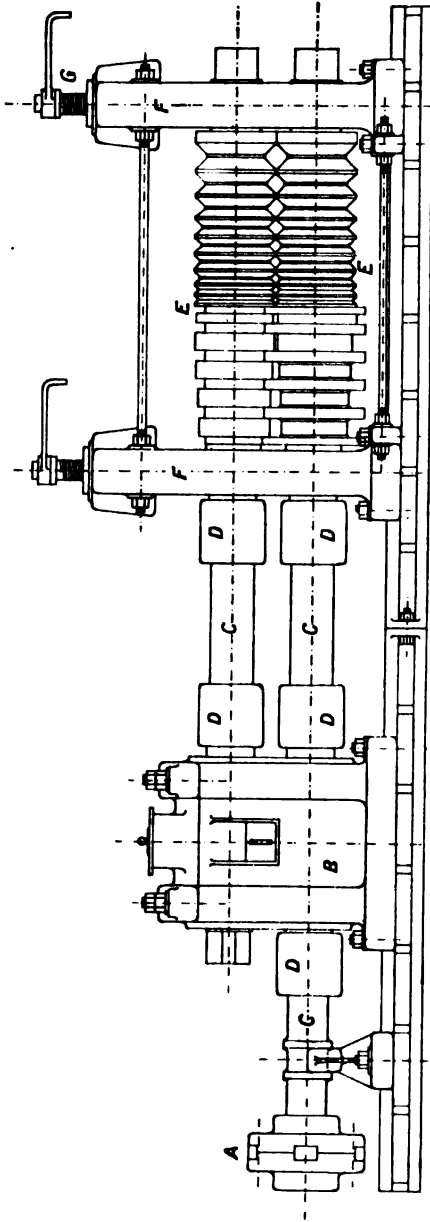

FIG. 18.—Puddle Rolls or Forge Train.

the more homogeneous mild steel. The explanation may be due to the fact that each fibre of wrought iron is surrounded by a protective covering of glass-like slag, which must first be broken down before the metal is attacked, whereas in the case of steel a fresh surface of the metal itself is constantly exposed as the oxide or rust formed falls off by expansion and contraction.

The Forge and the Mill.—By the “*forge*” is understood that portion of the works in which are situated the puddling furnaces, and the machinery employed in the production of the puddled bar. The latter operation comprises two distinct processes:—(1) *Shingling*, to expel the slag or cinder and consolidate the spongy mass of iron received from the puddling furnace into a rectangular slab or “bloom,” and (2) *rolling*, to convert the bloom into a “puddled bar” about 15 feet

long, 3 or 4 inches wide, and $\frac{3}{4}$ inch thick, suitable for subsequent reduction into bars or plates. Shingling is effected by means of blows from a hammer, or by direct compression in some form of mechanical *squeezer*. The latter is, however, not so effective as the steam hammer (for description see p. 41), which is now generally employed. The blooms produced in this way are passed forward, without re-heating, to the *puddle rolls* or *forge train*, which usually consists of two pairs of cast iron rolls about 18 inches diameter

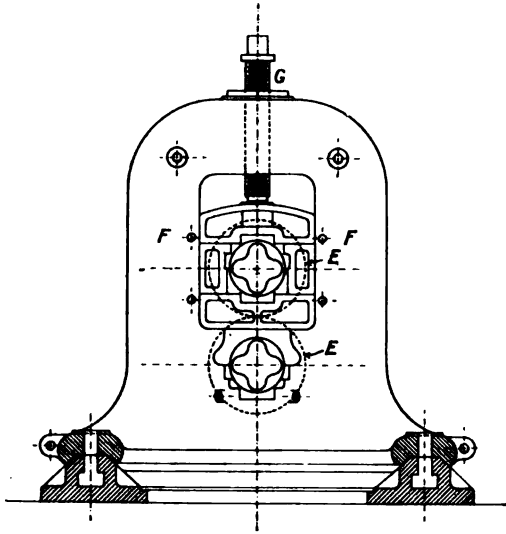

FIG. 19.—Housing for Rolling Mill.

and from 4 to 5 feet long, arranged in one line, and driven directly by means of a steam engine. The *roughing or cogging rolls* are, as a rule, placed on the left and are provided with a series of gothic or diamond-shaped grooves of diminishing depth, the surface of the grooves being notched or indented to give a better hold upon the bloom. The author is indebted to Messrs. Akrill, Ltd., of West Bromwich, for the drawing, Fig. 18, of a forge train of their manufacture. The flange coupling, A, connects to the steam engine, from which the rolls, E, are driven through a pair of *double-helical pinions* contained in the housing or casing, B. The connection between the lower pinion and the engine, and also between the pinions and the rolls, and between

the rolls themselves, is made by means of *breaking-spindles*, C, and coupling boxes or *wobblers*, D, as shown in detail in Fig. 434, p. 566. This is in reality a safety device, the spindles being designed to break first should any sudden or unusual resistance be encountered in rolling, and fracture of the rolls themselves is thus avoided. The ends of the rolls are turned down to form necks, which run in brass bearings in massive cast iron standards or *housings*, F, shown in detail in Fig. 19. Large *setting down screws*, G, operated by hand, and working through nuts fixed in the top of the housings, regulate the position of the upper bearings and enable the distance between the rolls to be adjusted. The *finishing rolls* on the right of the forge train resemble the roughing rolls except in the form of the grooves, which are rectangular or flat, diminishing in size towards the right. The bloom received from the shingling hammer is first inserted in the largest groove of the roughing rolls, and is passed through all the grooves in regular succession, being returned over the top of the upper roll after each pass. The *puddled bar* shows a crystalline fracture, with some appearance of lamination, due to the contained slag, which has not yet been uniformly distributed throughout the mass. In this form it is sent to the *Mill*, which comprises that section of the works where the puddled bar is cut up, piled, re-heated, and rolled out into various sections of "merchant" iron. The puddled bar is *cropped* or cut up in a shearing machine into pieces of from 1 to 4 feet long, depending upon the purpose for which it is intended. These pieces are arranged in alternate layers at right angles to form a rectangular *pile* or *faggot* from 4 to 12 inches square, which is raised to a welding heat in a *balling* or *re-heating furnace*, now usually fired by gas and provided with a regenerator, of the type shown in Figs. 299 and 300. Some oxidation takes place during heating, the oxide formed combining with the sand bottom of the furnace to produce a slag, known as *mill-furnace slag*, which flows to the bottom of the flue and is removed occasionally as required. When the welding temperature is reached, the pile is removed from the furnace on an iron bogie, or by means of tongs supported from an overhead run-way, and is taken to the *mill-train* for rolling into merchant iron. A good example constructed by Messrs. T. Perry & Son, Ltd., of Bilston, is shown in the photograph, Fig. 20. This, as in the case of the forge train,

consists of two sets of rolls, the *roughing rolls*, in which the pile is first "cogged down" or reduced, and the *finishing rolls*, in which it is converted into the form of section required. The housings and bearings in which the rolls run are similar to those of the puddle train, and the two sets are connected together and to the engine in the same manner. The bottom roll is provided with a *stripping plate* (see Fig. 435, page 566) one edge of which is carried upon a bar fixed to the end frames, the other edge resting upon the roll itself, and having suitable teeth or projections fitting into the various grooves. Any tendency to stick in the groove is thus overcome, and the possibility of the bar wrapping round the

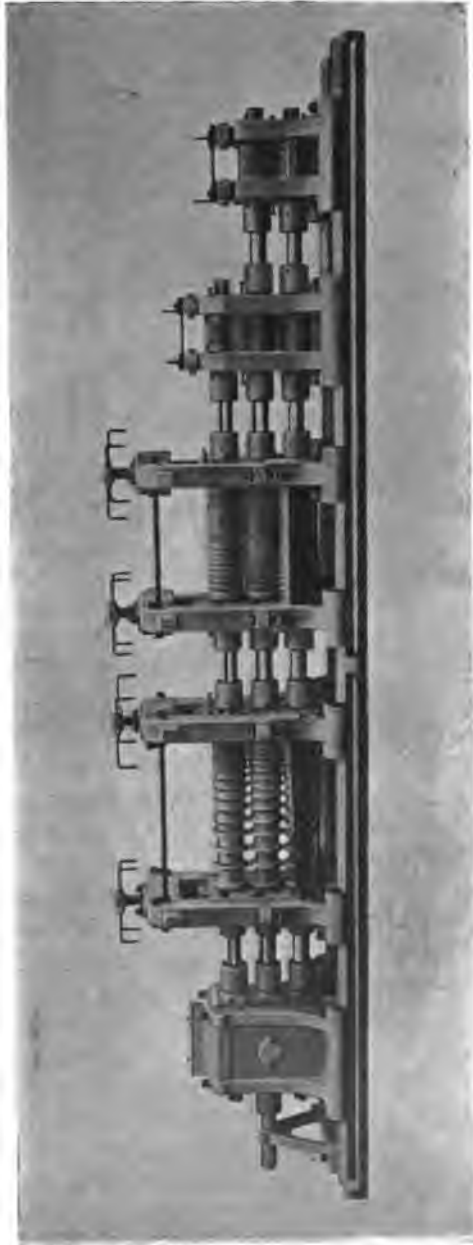

FIG. 20.—Mill Rolls, or Mill Train.

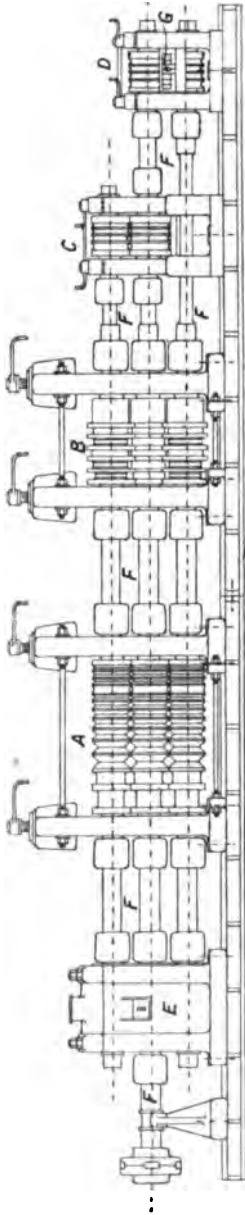

FIG. 21.—Bar Mill, or Guide Train.

bottom roll, or "collaring," as it is termed, is prevented. A *fore-plate* fitted with *guide jaws* for guiding the bar straight into the rolls is provided when rolling very light sections, which when hot, would otherwise be liable to bend and twist. This arrangement is seen applied to the small rolls on the right of the figure. The train so arranged is known as a *guide train*, and the product is spoken of as *guide iron*. The details of construction are clearly shown in the drawing, Fig. 21, which represents a bar mill or guide train made by Messrs. Akrill, Ltd., of West Bromwich. The first and second roughing rolls are seen at A and B respectively, and the guide rolls at C and D. The rolls are driven through double helical pinions contained in the enclosed housing, E, by means of coupling spindles, F. The guide rolls, C, are provided with oval grooves and the oval section produced passes through the guide jaws, G, into the round groove of the finishing rolls, D. The rolls shown at B are for flats, and when working on rounds these would be taken out, and another set with oval and diamond-shaped grooves substituted. The whole mill stands on a heavy girder section bed, of the same type as shown in Fig. 19. With *two high rolls*, still frequently employed, the work is returned over the top roll after each pass (see p. 566). This results in a great loss of time and labour, and as no work is done during

the return, the metal is allowed to cool down to no purpose. Two methods have been proposed to overcome the difficulty: (1) By the adoption of *three high rolls*, as in Fig. 20; and (2) by



FIG. 22.—Plate Mill, Low Moor Ironworks.

reversing the rolls after each pass. *Three high rolls* are often used not only for light work, such as hoop or guide iron, but are now being adopted for heavier sections, such as rails, girders, etc. Roughing and finishing sets are provided in each train, each

M.T.

E

consisting of three rolls placed one above the other, the middle roll being driven from the engine, and the others geared to it. After passing in one direction through the middle and bottom rolls, the bar is returned through the next groove between the middle and upper rolls. In a *reversing mill* the direction of rotation may be reversed either by means of some form of clutch operating alternately a direct and an intermediate gear drive from a continuously rotating engine, or the engine itself may be reversed, on the plan first introduced by Ramsbottom. For a *plate mill*, plain rolls are of course, employed, arranged as before in pairs for roughing and finishing respectively. Fig. 22 is from a photograph of the plate mill at Low Moor Ironworks, which is one of the largest in the country. The rolls are 32 inches diameter, and 11 feet long. Roughing rolls are usually of grain iron cast in sand, but those for finishing are chilled by casting in iron moulds. The top roughing roll is counterbalanced by levers and weights to permit the ready insertion of a bloom or slab of from 3 to 6 inches in thickness. In the mill described, the top finishing roll is driven through pinions, but, in some cases, revolves merely by friction with the plate in passing through. After each pass the distance between the rolls is reduced by means of setting down screws acting upon the bearings of the top roll. To enable both screws to be set down to the same amount, the wheel keyed upon the end of each screw is provided with a pointer moving round a notched or graduated ring fixed on the housing. In some cases, the screws are turned together by means of a shaft with bevel gearing, and in many recent examples a self-acting motion, driven by a small steam engine, or electric motor, is employed. With the large extent of surface exposed in the case of a plate, it becomes most important to avoid loss of time, and for this reason reversing mills have been extensively adopted. The engine, which is reversed each time the plate passes through the rolls, is fitted with slotted link-motion reversing gear, moved by small auxiliary steam cylinder and oil cataract. This is seen in the photograph of the engine at Low Moor, Fig. 23, which has a pair of cylinders, each 50 inches diameter, with a stroke of 5 feet, and is arranged to run at a speed of 50 revolutions per minute. The valves are of the piston type, 20 inches in diameter. This photograph, and also that of the plate mill, have been kindly supplied by

Mr. H. B. Woodcock, of Low Moor Ironworks. The reversing lever, and a second lever which controls an equilibrium stop valve in the main steam pipe, are placed outside the engine house, in

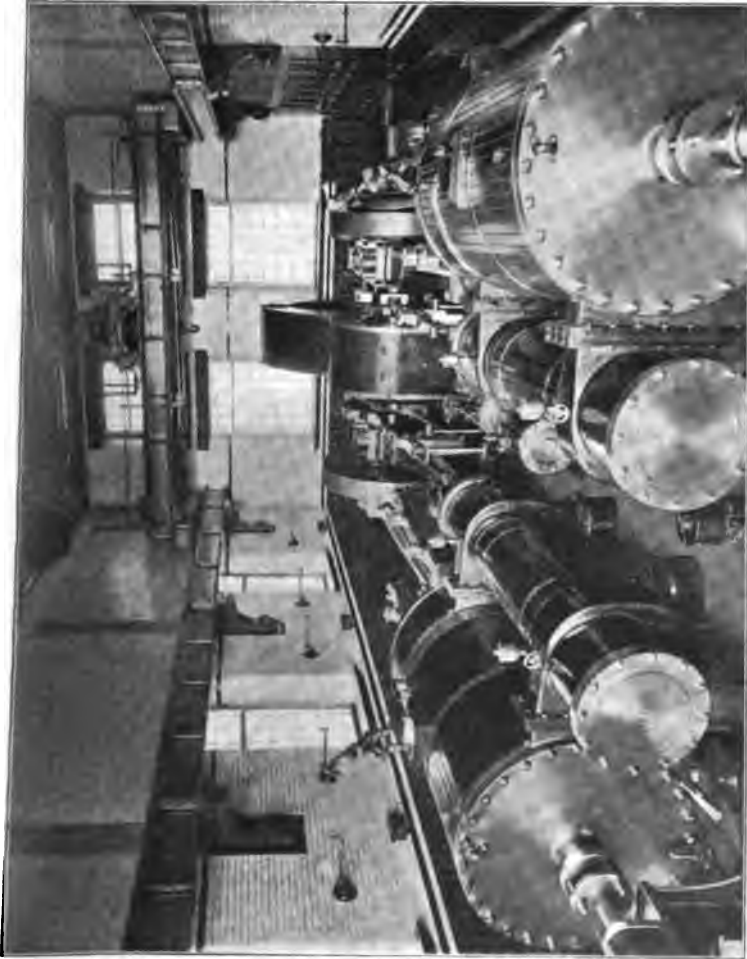

FIG. 23.—Reversing Plate Mill Engines, Low Moor Ironworks.

order that the man in charge may have the rolls constantly in sight when in operation. Feeding gear, consisting of friction rollers driven from the outer ends of the bottom roll, is fixed both front and back to assist in passing the plate backwards and forwards through the mill. On the front side, the end of the

plate is received upon a bogie, which is run out to afford the necessary support. In rolling plates, the slab is first passed between the roughing rolls always in the same direction until the required width is obtained, when it is turned at right angles and again rolled to effect the necessary reduction in thickness. The exact thickness is then given in the finishing rolls, the surface of which being maintained hard and true, imparts also a fine finish to the plate.

Consumption of Fuel in Iron-making.—To produce 1 ton of best iron from the ore, including calcination, smelting, refining, puddling, and re-heating, requires the consumption of about 4 tons of coal, the amount being increased to about 6 tons in the case of treble best quality. The total loss of iron from the pig to the merchant bar will average about 20 per cent. It will be seen later that the consumption of fuel and the loss of metal are both very much less in making steel.

Properties and Defects of Wrought Iron.—Wrought iron is almost chemically pure iron, containing only very small proportions of impurities, which, however, exercise a most important influence on its properties. Its chief characteristic is that it contains the smallest amount of carbon of any of the commercial varieties of iron. The carbon, which does not exceed from 0·1 to 0·25 per cent., is present entirely in the combined form, and the smaller the proportion the softer the iron will be. Wrought iron is practically infusible and cannot be cast in a mould. At a bright red heat, it may be hammered or rolled into various shapes, the former operation being termed forging. Raised to a white heat it becomes plastic, in which condition if two clean surfaces are placed in contact and subjected to pressure by hammering, they will unite or *weld* together, forming a perfect joint. Wrought iron does not harden when heated to redness and suddenly cooled by quenching in water. It ranks as one of the most ductile metals, and it may be drawn into very fine wire, or rolled out into sheets of extraordinary thinness. The presence of a small amount of phosphorus is very injurious, 0·25 per cent. sufficing to render the iron *cold short*, that is, the metal may be quite malleable and easily worked at a red heat, but is brittle and liable to crack when cold. Sulphur has the opposite effect, and it is most important that it should be excluded. As low a proportion as 0·03 per cent. causes decided *red shortness*, the iron

becoming brittle and unforgeable at a red heat, although possessing the usual properties when cold. Silicon is often present in



FIG. 24.—Crystalline Fracture of Wrought Iron when broken suddenly.



FIG. 25.—Cold Bending Test for Wrought Iron.

small quantity, and tends to produce hardness and brittleness, 0.35 per cent. being sufficient to render the iron cold short and deficient in strength. Hot or red shortness due to the presence



FIG. 26.—Drifting and "Ram's Horn" Tests for Wrought Iron.

of sulphur is perhaps the most potent defect which can exist in wrought iron, and is fatal to safe welding or difficult forging. If required for any important purpose, wrought iron should

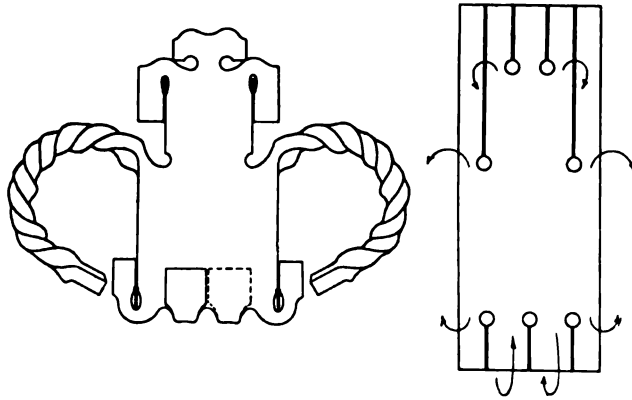

FIG. 27.—“Ram's Horn” Test for Plate.



FIG. 28.— Forge Tests for Rivets.

be subjected to *cold bending*, and also to forge or *smithing tests*. If a bar be nicked on one side with a chisel and bent over cold, it should display a fibrous fracture as shown in Fig. 17. The same quality round bar nicked all round and broken with a blow from a hammer shows a crystalline fracture, Fig. 24, the small size and appearance of the crystals being an indication of quality. Bar iron either square or round from $\frac{3}{8}$ to 1 inch thick, if of best Yorkshire quality, may be bent cold close upon itself without fracture, as in Fig. 25, and if from 1 to 3 inches thick should bend to an inner radius = half thickness of bar without fracture. As an example of a bending test, a knot may be tied on a round bar 1 inch in diameter in the cold state, but this cannot be considered as a severe test of quality. The same remark applies to a cold bend on a round bar $2\frac{1}{2}$ inches diameter, but a bend on a $2\frac{1}{2}$ -inch square bar, or on a bar 3 inches by 2 inches, which displays the curved edges due to compression on the inside of the bend, without showing any sign of fracture on the outside, can only be made with samples of excellent quality.

Bars and plates of any thickness may be bent and hammered close when hot without any appearance of fracture. In the hot forge test stipulated by the British Admiralty for wrought iron branded "best best," "a bar is punched with holes the diameter of which is $\frac{1}{3}$ the width of the bar, at distances of $1\frac{1}{2}$ and 3 diameters from the end of the bar, the holes being at right angles to each other. The holes are then drifted out to $1\frac{1}{2}$ times the width of the bar. The sides of the holes are then split, and the ends must admit of being turned back without fracture." The distension produced by drifting a punched hole is a severe test of quality. The so-called "ram's horn" test, Fig. 26, of splitting open the hole, and bending outwards the two sides, which in addition have perhaps been previously twisted, has been modified



FIG. 29.—Forge Test of Low Moor Rivet.

in an endless variety of ways, and is recognised as a useful proof of soundness. Fig 27 shows a "ram's horn" test on a piece of best Yorkshire iron plate by the Farnley Iron Co., Ltd., of Leeds.

The ductility of rivet iron is well shown by the manner in which it will endure flattening, as in Fig. 28. A very striking, though somewhat unusual, test carried out on a Low Moor iron rivet as shown in the photograph, Fig. 29, well displays the high

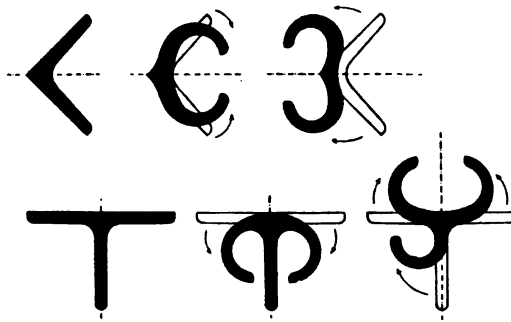

FIG. 30.—Forge Tests for Rolled Sections.

quality of the material. Angles, tees, channels, and other rolled sections are similarly subjected to hot forge tests as suggested in Fig. 30.

Analyses of Wrought Iron.

Constituent.	Ordinary Merchant.	Low Moor.
Carbon	0·1 to 0·25	0·081
Silicon	trace „ 0·10	0·104
Manganese	trace „ 0·25	trace
Phosphorus	0·04 „ 0·20	0·041
Sulphur	0·02 „ 0·10	trace
Arsenic	—	0·008
Iron	99·1 „ 99·7	99·766

CHAPTER VI.

CLASSIFICATION AND METHODS OF MANUFACTURE OF STEEL.

Definition of Steel.—Chemically, ordinary steel is defined as an alloy of iron with a small proportion of carbon, varying from 0·1 to 1·25 per cent. Other elements may be present to greater or less extent, but are, strictly speaking, impurities. It has become necessary to refer to this material as “carbon” steel. Small quantities of certain other metals, such as manganese, silicon, nickel, chromium, tungsten, etc., may be alloyed with iron and carbon, imparting valuable properties to the metal, which is then known as manganese steel, nickel steel, etc. Formerly, steel was defined as an alloy of the chemical element iron with carbon, capable of being hardened by heating to redness and then quenching in water, in which respect it was distinguished from wrought iron. At the present time, an enormous quantity of steel is made containing not more than 0·2 per cent. of carbon, and this material will not harden appreciably on sudden cooling. To this product, the name of *mild, or low carbon steel* has been given. With more carbon, say up to 0·5 per cent., a variety known as *medium steel* is obtained, which is suitable for rails, tyres, etc., and which becomes perceptibly harder by quenching in cold water. Beyond this, with carbon up to 1·25 per cent., *hard or high carbon steel* results, which possesses the property of hardening and tempering in a marked degree, and is suitable for tools, files, etc. The influence of carbon content on the strength and ductility of steel is shown clearly in the diagram Fig. 31. There is, however, no line of demarcation between these varieties, which merge gradually one into the other. Still, all the numerous varieties of material now known as steel, have one peculiarity which serves to distinguish them from both wrought and cast iron. They are all produced in a molten condition, and are at once cast into ingots, which are afterwards rolled or hammered. Briefly, cast iron may be cast, but cannot be forged; wrought iron may be forged, but cannot be cast;

and steel in process of manufacture is cast, and afterwards may be forged. The melting point depends upon the proportion of carbon present, ranging from 2500° F. for hard steel to 2900° F. for the mildest varieties. If heated beyond a certain temperature, steel assumes a friable condition, and is known as "burnt," which results in permanent injury to the metal. Hence steel must be worked at a lower temperature

INFLUENCE OF CARBON CONTENT ON THE STRENGTH & DUCTILITY OF STEEL.

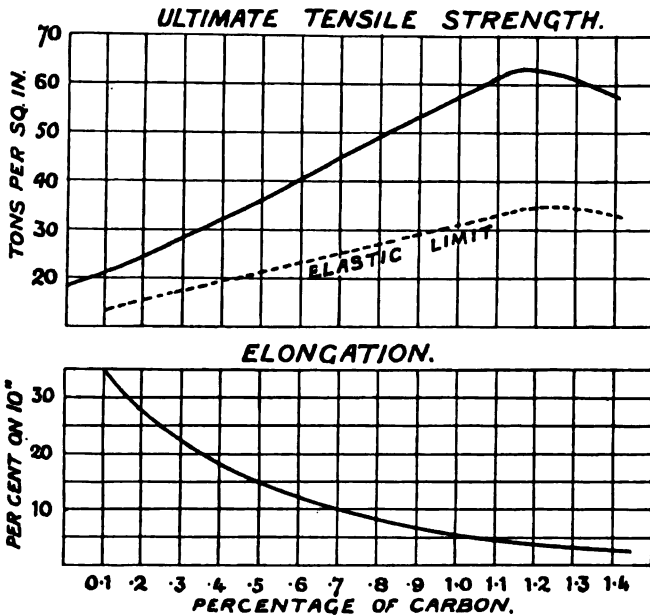

FIG. 31.

than wrought iron, and greater care, especially in the case of the harder varieties, must be exercised in its treatment. Mild steel is easily forged when heated, and if the carbon content does not exceed 0.3 per cent. it may be welded, although not so easily as wrought iron, because the latter, on account of the higher temperature at which it may be safely worked, becomes much softer than steel. Indeed, the safe range of temperature for steel is much narrower than for wrought iron, and welds cannot be relied on with so much certainty. This explains why steel has

not been able to take the place of wrought iron for chain making, and why best Yorkshire iron is still preferred for difficult smith-work where repeated heating may be necessary. The strength and elasticity of mild steel exceeds that of the best wrought iron, and much larger pieces in the form of forgings, bars, plates, rails, etc., can now be produced, at one-half the price of best Yorkshire iron. For structural purposes, as in bridgework, etc., where smithing and welding are easily avoided, steel has entirely displaced wrought iron. The superior ductility and flanging properties of steel plates have rendered the use of wrought iron for boiler-making obsolete, and in fact the thick plates required for marine boilers of large diameter could not possibly be produced in iron. On the other hand, experience seems to have established the fact that best wrought iron is less susceptible to "fatigue," and to suddenly applied and oft-repeated stresses, and is better able to resist continued percussive action. Thus, in stationary engine practice, crank pins of Low Moor iron have worked quite successfully for many years, where steel of the highest quality has fractured repeatedly after running only a few weeks. Steel is also seriously affected by such action as shearing or punching. Steel plates should on no account be punched, but must be drilled. The crushing stress exerted upon the edge of a plate in shearing, is found to be much less prejudicial in the case of wrought iron than with steel. It is dangerous to work steel at a blue or a black heat, the resulting injury being much greater than if the steel had been strained when cold. This property is known as "blue shortness." Steel which has been injured by working at a blue heat may be restored to its original condition by proper annealing. Similarly, steel plates which have been punched, or subjected to local action as in flanging, must afterwards be annealed. The annealing furnace must allow of the entire piece or plate being heated at one time to full redness, after which the article treated is allowed to cool down gradually under a layer of ashes or other badly conducting material.

Classification of Steel.—The different varieties of steel may be very conveniently classified according to the process of manufacture. The dominant factor in the composition of steel is the amount of carbon contained, and as in this respect steel occupies a position intermediate between wrought iron and cast iron, it

will be readily understood that the methods employed for the production of steel are based upon either (1) the addition of carbon to wrought iron, or (2) the decarburisation of cast iron. Another method is (3) by the direct reduction of the ore, but although no doubt possible, this process is very uncertain and impracticable, and is not at present in use. Grouped according to the first two methods, it will be found that steel is being made on a large scale at the present time by the following processes:—

(1) *The Cementation Process*, in which wrought iron bar is heated for some time in contact with carbon. This is still the most important, and practically the only method of producing the “crucible cast steel” used for cutting tools.

(2) *The Bessemer Process*, in which cast iron is decarburised by blowing air through the molten metal.

(3) *The Siemens Process*, in which the decarburisation of cast iron is effected by adding rich oxides in the form of iron ore to the molten metal in an “open-hearth” gas-fired furnace. In a modified form, known as the Siemens-Martin process, pig iron is melted with wrought iron scrap, no ore being added. On account of the difficulty in obtaining wrought iron scrap at the present time, this process is now no longer used. The terms “Siemens” and “Siemens-Martin” are employed very loosely, and are often understood to mean one and the same thing. The “Siemens” is essentially the “pig and ore” process, the “Siemens-Martin” being just as fundamentally that of “pig and scrap.” In either case, the furnace is always of the gas-fired Siemens type, worked on the regenerative system. In the ordinary Bessemer and Siemens processes, pig iron containing phosphorus cannot be treated, on account of the acid nature of the siliceous lining.

(4) *The Basic, or Thomas-Gilchrist Process*, in which the Bessemer converter, or the Siemens open-hearth furnace, as the case may be, is lined with basic material such as dolomite or magnesite, to effect the removal of phosphorus.

CHAPTER VII.

CRUCIBLE CAST STEEL—CEMENTATION PROCESS.

The Cementation Process.—This is the oldest of all the commercial processes of steel-making, and was first established in Sheffield during the 18th century. Hammered bars of refined Swedish iron, 3 inches wide, $\frac{5}{8}$ inch thick, and from 8 to 10 feet long, are embedded in charcoal, and the air being excluded, are kept at a yellow heat for a period of eight to ten days. The *converting or cementation furnace*, Fig. 32, resembles a glass-house furnace in external appearance, having a *hovel* or conical chimney, A, about 40 feet high, inside which is a rectangular chamber of firebrick, B, arched over at the top, and containing two long troughs, or *pots*, C. The latter are built of firestones, supported on narrow piers or *benches* of masonry or brickwork, which are arranged to leave a series of flues, D, all round the sides and ends of the pots. Running down the centre between the pots is a narrow fireplace, E, having a firing door at each end. A man-hole, F, is left at the end of the chamber, through which the bars are charged into and withdrawn from the pots, the opening being bricked up when the furnace is at work. The pots are charged with about 20 tons of bar by first spreading a layer of charcoal nibs, $\frac{1}{2}$ inch deep, over the bottom, and upon this is placed a layer of bars, leaving spaces $\frac{1}{2}$ inch wide between them to be filled with charcoal. Alternate layers of charcoal and bars are introduced in this way until the pots are full, leaving a covering of charcoal on the top. The whole is then luted over with "wheelswarf," the material obtained from the slow wearing away of grindstones, and which, under the action of the high temperature, fuses and renders the pot air-tight. After lighting the fire, the temperature is gradually got up in about a couple of days to full redness, at which it is maintained for about a week, until the process has gone sufficiently far. This is known by withdrawing trial or *tap bars* left purposely so as to be accessible from a small opening or *tap-hole*, G, in the end of each pot,

which can be reached through an opening in the outer wall of the furnace. The degree of carburisation can be judged from the appearance of the fracture of the trial bar, the steel produced being classified under six or seven numbers, or "tempers." No. 1 or "spring heat" containing $\frac{1}{2}$ per cent. carbon, exhibits an outer skin of steel surrounding a core of iron, called the

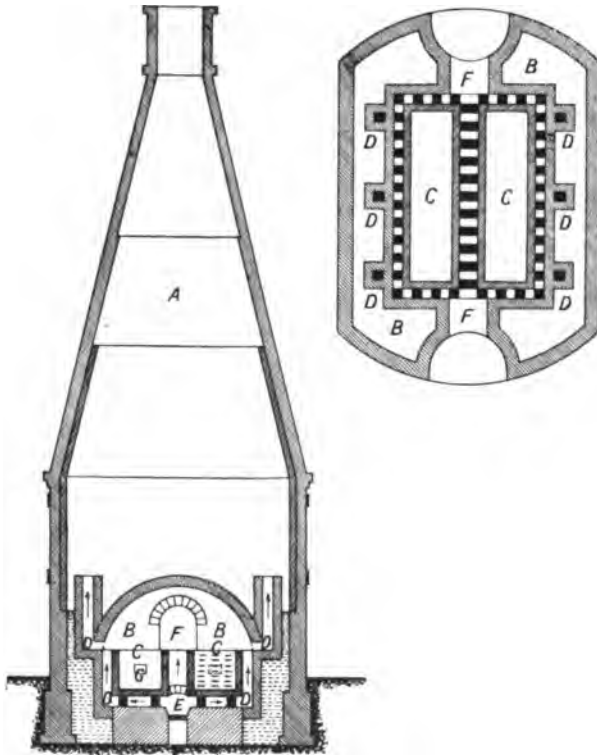

FIG. 32.—Cementation Furnace.

"sap." In No. 3 or "single shear" heat, containing $\frac{3}{4}$ per cent. carbon, the fracture shows more steel on the outside, and less iron in the centre, whilst in No. 4 or "double shear" in which the carbon has reached 1 per cent., the steel and sap are present in about equal amounts, until in No. 5 or "steel through" heat, when the carbon has increased to $1\frac{1}{4}$ per cent., the sap has been "killed," and all traces of iron are lost. The desired "temper"

having been reached, the fire is withdrawn, and the pots are allowed to cool slowly, the operation of "drawing the heat," as it is termed, lasting about a week, so that the whole process occupies about three weeks. When cool, the pots are opened, and the surface of the bars which originally was quite smooth, is found to have become very rough, and covered with blisters,

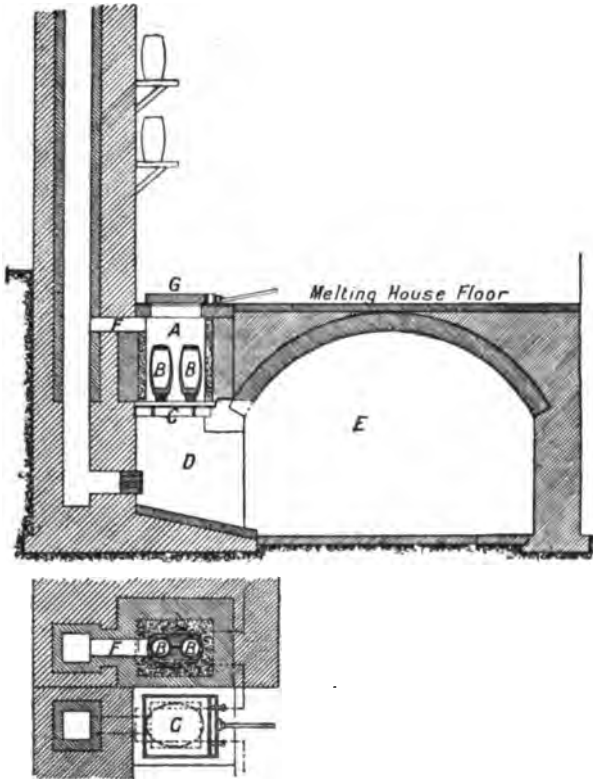

FIG. 33.—Crucible Cast Steel Melting House.

which, if of small size and uniformly distributed, indicate good quality of metal. The bars of *blister steel*, as it is now called, are broken into short lengths and sorted out according to the fracture. To obtain greater homogeneity the pieces are piled, re-heated, welded together, and drawn down under the hammer, the product being known as *single shear steel*. This is again cut up, re-heated, welded and drawn down into bars of *double shear steel*,

which although fairly uniform in composition, is never quite homogeneous and still contains impurities. These defects can only be removed by fusion, or by melting the blister steel in crucibles, the molten metal being poured or cast into iron moulds to obtain sound and perfectly homogeneous ingots of *crucible cast steel*. This process was introduced into Sheffield by Huntsman in 1740, and is still in use with very little modification. The *melting holes*, A, are simple air furnaces, Fig. 33, consisting of a series of rectangular pits of brickwork arranged below the level of the melting house floor, and along one side of the building. The holes are lined with ganister or firebrick, brought up to an oval shape and capable of holding two pots or crucibles, B, which stand upon the grate bars, C, the ash pit, D, communicating with the cellar or vault, E, formed beneath the floor. Each fire has its own flue, F, leading into a chimney stack which is about 40 feet high, the draught being regulated by a damper controlling an opening into the ashpit. The "hole" is covered with a square quarry of firebrick, G, about 3 inches thick fixed in an iron frame provided with a handle. The crucibles for melting steel are almost invariably made of fireclay, although graphite has been used to a limited extent. They are made by hand in cast iron moulds from mixtures of fireclays obtained from the coal-measures, and usually a special department of the works is constantly engaged in their production. The crucibles are allowed to season for a fortnight on shelves fixed round the sides of the melting house, and before use, are slowly raised to redness in annealing ovens. They are then placed each on a fireclay stool, about 4 inches thick, resting on the grate bars in the melting holes, and a coke fire is filled up level with the top. The charge of about 60 to 80 lbs. of blister steel cut up into small pieces is now introduced by means of an iron funnel, the cover or lid, also of fireclay, is put on, the fire made up to the top with coke, and the furnace closed. The fire is usually made up three times, and the melting is complete in three or four hours. It is important that the metal should be "dead melted" or "killed" before casting, *i.e.*, it must be heated for a sufficient length of time after fusion has actually taken place, otherwise it will teem "fiery," throwing off sparks, and the ingots will be unsound or honeycombed. The metal must also be "skimmed" before teeming, the slag floating on the top being removed by means of a "mop," which is a lump

of slag attached to the end of an iron bar. Gas furnaces on the Siemens regenerative principle (to be described later) have been employed for melting steel in crucibles, but although using much less fuel, they have never met with extended use. The workman who lifts the crucibles from the fire is known as the "puller-out." The "lifting out tongs" have half-round jaws which grasp the belly of the crucible, and when the pot has been withdrawn, it is seized by the "teemer," by whom its contents are poured at once into an ingot mould. The moulds are of cast iron, and are constructed in halves, held together by rings placed round them, and tightened by keys or wedges. Just before using, the interior of the mould is "reeked" or thickly coated with lampblack from the smoky flame of burning coal tar or resin, to prevent the ingot "sticking."

The changes which occur during the production of crucible cast steel are shown in the following analyses:—

	Swedish Bar Iron.	Blister Steel.	Crucible Cast Steel.
Carbon	Per cent. 0·10	Per cent. 0·5 to 1·5	Per cent. 0·7 to 1·6
Silicon	0·03	0·03	0·12
Manganese	Trace	Trace	0·20
Sulphur	0·003	0·003	0·005
Phosphorus	0·02	0·02	0·02

CHAPTER VIII.

THE BESSEMER, AND THE BASIC BESSEMER PROCESSES.

The Bessemer Process.—In 1855, Sir Henry Bessemer patented the method of producing steel by blowing air through molten pig iron, whereby carbon, silicon, and manganese are oxidised and burnt out, sufficient heat being developed by their combustion to keep the metal in a fluid condition, so that finally it may be cast directly into ingots. The operation is carried out in a vessel termed the *converter*, Fig. 34, which consists of a casing, A, of thick plates rivetted together, and fixed to a strong cast steel frame or *trunnion ring*, B, at the centre. The trunnion ring has two arms or trunnions supported in suitable bearings, upon which the converter may be rotated. This is effected by making one of the trunnions, C, solid, and fixing upon it a pinion, D, which gears with a rack attached to a double-acting hydraulic ram, E. The trunnion, F, on the opposite side is hollow, and through it the blast is conducted down a flat pipe or “goose-neck,” G, at the side of the converter to the *blast box*, H, at the base. This forms a removable *bottom*, J, to the converter, to which it is attached by bolts and cotters. Fixed to the upper side of the box is the *guard plate*, K, having 18 or 20 circular holes spaced at equal distances apart to contain the cylindrical fireclay tuyeres, L, which are about 2 feet long and are perforated longitudinally with 16 or 18 holes five-sixteenths of an inch in diameter. Through these the blast is introduced in small jets into the liquid metal. The *neck or throat*, M, of the converter is fixed at an angle of about 30° with the body, so that when the vessel is in an upright position, as in Fig. 34 (a) and (b), the sparks and flame discharged during the “blow” are directed into an open chimney-stack. The neck also serves the purpose of a spout when the converter has been rotated into the horizontal position for pouring the metal into the ladle as shown at (d). A hood is fixed above the converter to receive the stream of sparks discharged during

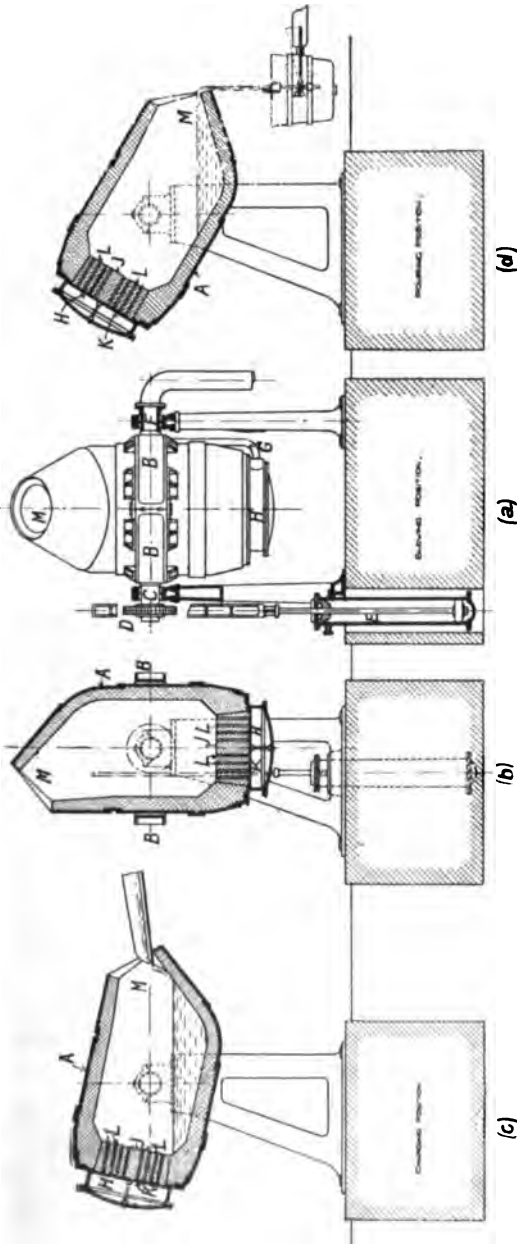

FIG. 34.—Bessemer Converter.

the passage from the horizontal to the vertical position. The converter is lined with refractory material, usually ganister, to a thickness of 10 or 12 inches at the sides, and about 18 inches at the bottom. Ganister is a highly siliceous sandstone found

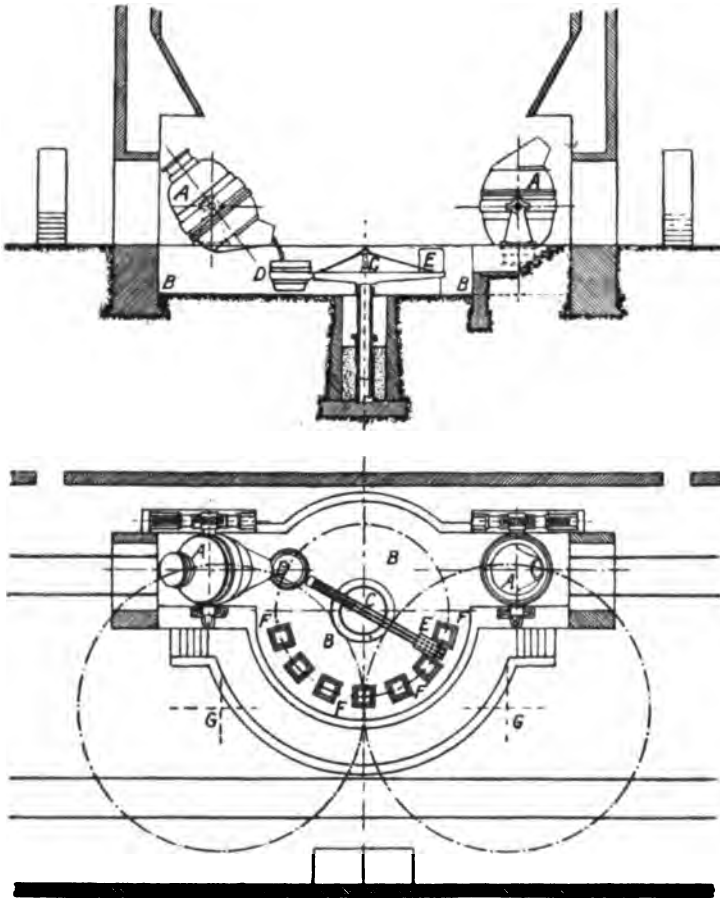

FIG. 35.—Arrangement of Bessemer Plant.

below the coal measures in the neighbourhood of Sheffield. It contains about 90 per cent. silica, and from this fact the process is often spoken of as the *acid process*, and the product as *acid steel*. The ganister is ground to a coarse powder, and is mixed with sufficient water to render it plastic. It is then rammed

in between the shell of the converter and a wooden core of the same shape as the interior. As the bottom wears out much more rapidly than the lining it is now always made detachable, so that it may be easily removed when worn, and replaced in a very short time. In preparing the bottom, wooden dummies of the same size and shape as the tuyeres are inserted in the holes of the bottom plate, and fluid ganister is well rammed between them. The bottom having been dried, the dummies are removed, and the tuyeres put in the holes left. The converter is now generally made of 10 tons capacity, measuring 7 or 8 feet diameter inside the lining, the body being about 10 feet high, and the hood 5 or 6 feet in addition. What is known as a *single Bessemer plant*, Fig. 85, as arranged on the British system, consists of a pair of converters, A, A, placed on opposite sides of the circumference of a circular *casting pit*, B, about 30 feet in diameter and 3 feet below floor level. At the centre of the casting pit is fixed vertically the cylinder of a hydraulic crane, C, the ram of which carries a narrow platform or stage, composed of two horizontal girders. At one end of the platform is the ladle, D (of the type shown in section in Fig. 286, page 842), built up of steel plates, and lined with ganister. The ladle is poured from a fireclay nozzle or *tap-hole* in the bottom, the flow of the metal, free from slag, being regulated by a fireclay *stopper* fixed upon the end of an iron rod covered with a *sleeve* of fireclay. The rod or *swan's-neck* is bent over the top of the ladle, and connected at the side to a lever, by means of which the stopper may be raised or lowered. Mechanism is also provided for rotating the ladle on trunnions, so that it may be turned over to empty out slag, etc., into the slag pit. The ladle is counterbalanced by an iron poise weight, E, at the opposite end of the platform, and is capable of being raised or lowered by the hydraulic ram, or of being rotated round the centre by means of gearing on the platform of the crane. Arranged in a circle round the outer edge of the casting pit are the *ingot moulds*, F, F, of cast iron, either of octagonal or square form, tapering upwards. To permit of their ready removal or "stripping" from the ingots, as soon as the latter are sufficiently solidified, the moulds are open top and bottom, and stand on iron blocks. Two hydraulic cranes, G, G, are placed at opposite corners of the casting pit for stripping the moulds from the ingots and afterwards removing the ingots

from the pit. The *blowing engines* are usually of the direct acting horizontal type, arranged as a pair. The pressure at which the air is supplied is from 20 to 25 lbs. per square inch,

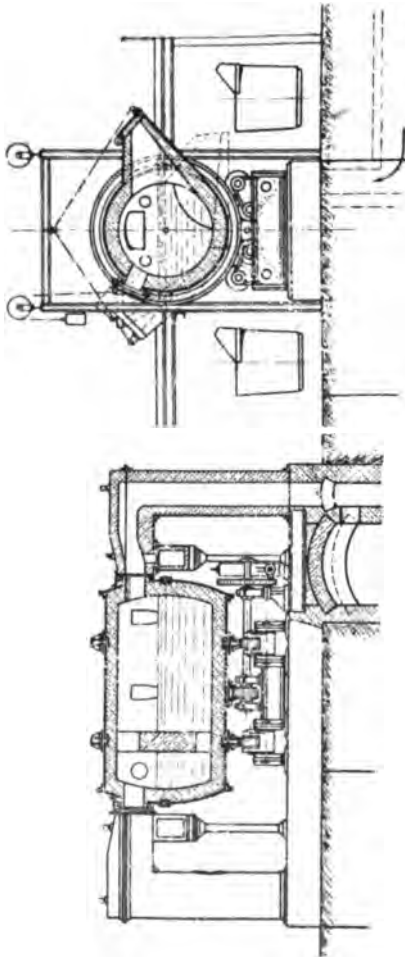

FIG. 36.—Metal Mixer.

and must be sufficient to overcome the head of fluid metal in the converter. The blast is used cold, but the oxidation which takes place, especially of the silicon in the iron, produces a very high temperature, which is imparted to the contents of the converter. The molten pig iron from the blast furnace is not taken directly to the converter, but a quantity of from 150 to 250 tons is kept constantly stored in a large vessel termed a *metal mixer*, Fig. 36, which is lined with fire-brick, and may be tilted on rockers by means of a hydraulic ram in order to discharge a portion of its contents into the ladle in which it is transferred to the converter. The use of the mixer not only ensures greater regularity in the iron, especially if supplied from several blast furnaces, but it is

found that by allowing the metal to stand for some time, the percentage of sulphur present is much reduced, sulphide of manganese being separated in the form of slag. In a works not connected with a blast furnace, the pig iron is melted in a cupola exactly as in the foundry.

Method of Conducting the "Blow."—The converter, with its lining previously raised to a red heat, is brought to the horizontal position, and the charge of from 10 to 15 tons of molten metal is introduced by means of a clay-lined trough entering the mouth of the vessel. The shape of the converter is such that when in the horizontal position it can hold the charge without reaching the level of the tuyeres, Fig. 84 (c). The blast is first turned on, and the converter then raised to the vertical position, Figs. 84 (a) and (b), the liquid metal being in this way prevented from running into the tuyeres. At first, a shower of sparks is ejected from the mouth of the converter, but with very little flame, and that of a faint yellowish-red colour. This lasts for three or four minutes, and constitutes the first stage of the blow, comprising changes similar to those which occur in the first part of the puddling process, *i.e.*, the graphitic carbon passes into the combined form, and the silicon is oxidised to silica, which combines with oxides of iron and manganese to form slag. The temperature now rises very rapidly, and the flame becomes larger in volume, and more luminous, and finally of a brilliant dense yellow colour. This is the second stage, or "boil," which lasts about ten minutes, and is equivalent to the boiling stage of the puddling process. The metal is now in a state of violent agitation, due to the escape of large quantities of carbon monoxide produced by the oxidisation of the carbon by the blast. The pressure of the blast is now reduced, the intensity and volume of the flame gradually giving place to a pale transparent amethyst tint, with fewer sparks. The third, or "fining," stage, in which the remainder of the carbon and manganese is removed, is now reached, and in about twenty minutes from the commencement of the blow the flame suddenly "drops," indicating that the decarburisation of the charge is complete. The converter is at once turned down to the horizontal position, and the blast shut off. The proper quantity of ferromanganese, previously weighed out, is thrown into the converter, which is allowed to stand for a few minutes until all agitation has subsided. Ferromanganese is a variety of pig iron very rich in manganese and containing also from 6 to 7 per cent. of carbon. In practice, it is not possible to stop the blow with the required amount of carbon remaining in the metal. It is found preferable to remove the whole of the carbon during the blow, and then "recarburise,"

or add the exact amount of carbon to convert the charge into mild, medium, or hard steel of the desired quality, by the addition of ferromanganese, or spiegeleisen. Until this is done, the decarburised metal may be described as burnt iron, being red-short and unweldable, or "rotten," as it is termed. During the blow, some oxidation of the iron is inevitable, and the oxide of iron produced dissolves in the metal, rendering it brittle and unworkable. The manganese in the ferromanganese decomposes the oxide of iron, forming manganese oxide, which passes into the slag. The converter is next turned down, and its contents discharged into the ladle, Fig. 34 (*d*), followed by a layer of slag to protect the molten steel and prevent radiation. After the ladle has been moved away, the converter is turned mouth downwards and the slag run out, the blast being turned on for a few seconds to facilitate the operation. The ladle is rotated and brought over each of the ingot moulds in succession, Fig. 35, and the molten steel is run in at the top. When full the surface of the liquid metal is covered with sand, and the moulds are stripped from the ingots as soon as the latter are sufficiently set. As the ingots are still much too hot in the interior to admit of immediate rolling, they are placed in *soaking pits* for about an hour. Each pit is somewhat larger than an ingot and of ample depth to contain it. It is thickly lined with firebrick, and is closed with a lid or cover to exclude air. The excess of heat in the interior of the ingot passes through the outer layers, and is taken up by the brickwork, from which it is radiated back again. This results in a uniform temperature being obtained without the use of fuel. The ingot can then be rolled in the cogging mill without re-heating.

As neither sulphur nor phosphorus are removed during the blow, the pig iron employed in the "acid" Bessemer process must be free from these impurities. At the same time, as the high temperature required in the converter is obtained mainly by the combustion and oxidation of silicon, that element must be present in the proportion of about $2\frac{1}{2}$ per cent. What is known as "Bessemer pig," because it is specially suitable for the Bessemer process, is smelted from hematite ores free from phosphorus and sulphur.

The Basic or Thomas-Gilchrist Process.—Phosphoric pig irons, such as those smelted from Scotch or Cleveland ores, and also largely produced on the Continent, are not suitable for con-

version into steel by the original Bessemer process, carried out in a siliceous or acid-lined converter. Although phosphorus is readily oxidised, the resulting phosphoric acid (P_2O_5) must be combined with a basic substance to effect its removal in the slag. The addition of lime might accomplish this object, if it were not for the fact that it would enter into combination with, and would thus rapidly destroy, the acid lining. This led to the introduction by Thomas and Gilchrist in 1878 of the "basic process," in which a strongly basic, and at the same time highly refractory, lining, prepared from dolomite or magnesian limestone, is substituted for the ordinary ganister lining of the Bessemer converter. The dolomite, after being burnt and ground, is mixed with anhydrous tar, and is pressed in cast iron moulds into the form of bricks, which are burnt at an intense white heat. The converter is lined with these *magnesian bricks*, laid in a cement of

anhydrous tar, the thickness at the sides being about 15 inches. The *bottom* is made about 2 feet thick, of the same materials as the bricks, and is similarly formed in an iron mould by hydraulic pressure, a number of holes about $\frac{1}{2}$ inch in diameter being left as tuyeres. The mould is then placed in a kiln and gradually raised to a red heat, which drives off the tar, and leaves a hard compact mass. The arrangement of the plant

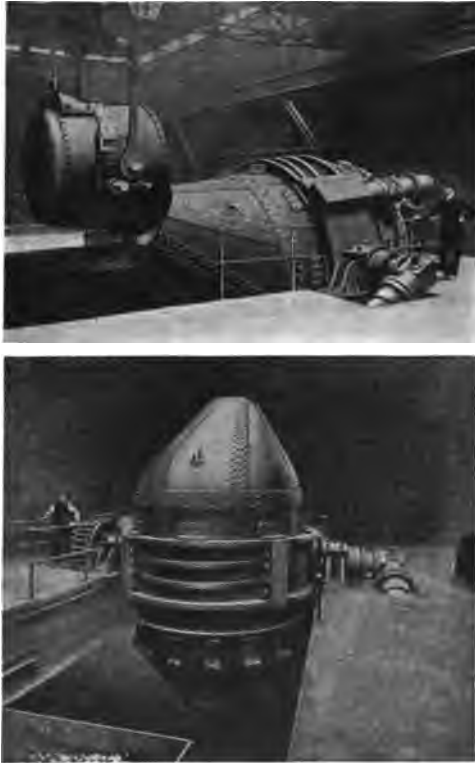

FIG. 37.—Basic Converter.

is in general the same as for the acid process. Fig. 87 shows two views of a 15-ton basic Bessemer converter supplied to Messrs. Walter Scott, Ltd., Leeds Steel Works, by the Lilleshall Co., Ltd., Oakengates, Shropshire. The pinion of the tipping gear is seen on the left of the lower view, in which will also be noticed the removable bottom, connected by hinged straps to the body of the converter. Owing to the nature of the process, the basic lining wears out very rapidly, and there is also considerable accumulation of slag after each blow. Frequent repairs are therefore necessary, which are greatly facilitated by the use of the "loose bottom." The upper view shows the method of charging the converter, and the hollow trunnion with the blast pipe is clearly seen. The converters used in the basic process are frequently of the concentric type, *i.e.*, the neck is not fixed at an angle to the body, but is concentric with it, the mouth being parallel to the bottom. In this way readier access is afforded for the removal of any refractory slag. The converter after lining is gradually warmed up, and a quantity of lime, equal to about 15 per cent. of the weight of pig iron, is put in, and is strongly heated by slight blowing. The charge of about 10 tons of molten iron is then run in from the ladle, the blast turned full on, and the converter rotated into the vertical position. The blow takes from fifteen to twenty minutes, and is attended with the same changes as in the acid process, until the removal of the carbon is indicated by the "drop" in the flame. The "after blow," as it is termed, now commences, and is continued for about three minutes longer. This is the peculiar feature of the basic process, resulting in the removal of the phosphorus. It is very important that the amount of silicon in the pig iron for the basic process should be small, not exceeding 1 per cent., as otherwise the silicon would attack and rapidly destroy the basic lining, and a much larger quantity of lime would be necessary. Moreover, silicon is no longer to be regarded as the chief heat-producing element, its place in this respect being taken by phosphorus. This is especially the case during the "after blow," when the temperature rises rapidly to about 3200° F., dense red-brown fumes being emitted. The flame does not, however, give any indication as to the completion of the process, and when it is judged that the phosphorus has been eliminated, the converter is turned down and the blast shut off. By means of a small

spoon-like ladle with a long handle, a sample is taken, and after casting in a mould, is hammered out flat, cooled in water and broken. With practice the extent to which dephosphorisation has been carried can be judged from the fracture. If still incomplete, the converter is turned up and blowing is continued, until finally a satisfactory sample is obtained. The slag is then immediately run off, the proper quantity of spiegeleisen or of ferromanganese is added to effect the necessary recarburisation, and the metal run into the ladle in the usual way. The remaining operations are conducted exactly as in the acid process. The slag, which may contain as much as 30 per cent. of phosphates of lime and magnesia, is of considerable value as a fertiliser for agricultural purposes, and is ground up and sold as manure. In spite of the great advantage that it permits of the use of cheaper pig iron, the basic process is in itself more costly to work than the ordinary or acid process, the quantity of lime used being very large, and the output per converter much less. It is generally contended that basic steel is neither so reliable nor so uniform in quality as the acid product, due in all probability to the fact that it is extremely difficult to know exactly when the process is completed. For such uses as rails, rolled joists, and other sections the basic process is nevertheless largely employed in this country, and in Germany it forms the chief means of production.

Comparing the acid with the basic Bessemer process, it will be noticed that the heat-producing agent in the former case is the silicon, and in the latter the phosphorus. The chemical composition of the pig iron used must therefore be adjusted to these requirements, and on the average may be taken as follows:—

Constituent.	Acid Process.	Basic Process.
Carbon	3·6	3·4
Silicon	2·5	1·5
Manganese	0·3	0·5
Phosphorus	0·05	2·2
Sulphur	0·05	0·06

CHAPTER IX.

THE SIEMENS OR OPEN-HEARTH PROCESS—ELECTROTHERMIC MANUFACTURE OF STEEL.

The Siemens or "Open-Hearth" Process.—Although several modifications of this process are in use, all of them are conducted in *gas-fired regenerative furnaces* of the type originally introduced by Sir W. Siemens with the object of obtaining a high temperature and at the same time of effecting economy in fuel. For this purpose, the principle of the Cowper hot-blast stove (p. 23) was applied in the construction of the *regenerators* for raising to a high temperature both the gas and the air required for its combustion. The arrangement may be best described by reference to a recent example by Messrs. Wellman-Seaver and Head, Ltd., of London. The *furnace*, A, Fig. 38, is of the reverberatory type, with the hearth carried upon cast iron *bath plates*, B, kept cool by allowing the air to circulate freely beneath them. The plates are first covered with a course of firebrick on edge, upon which the *bottom*, C, is formed of successive layers of refractory sand about an inch thick, each layer being "fritted" or vitrified by heating with gas before the next is put on. When a total thickness of about 15 inches has been reached, a quantity of slag and hammer scale is introduced and melted, and is spread over the bottom until no more is absorbed. The hearth slopes in all directions towards the *tap-hole*, D, at the back of the furnace, and from this a spout or *lander*, E, is arranged to run the metal into the ladle. Three openings, F, (see also Fig. 39), are usually provided in the furnace front, through the two outer of which the charge of pig iron is introduced; the ore or scrap is added during the process through the central or working door when the furnace is at work. The openings are closed by doors, which consist of iron frames enclosing a slab of firebrick, and the doors are suspended by chains from counter-balanced levers, by which they are raised and lowered. The end walls or *blocks*, G, of the furnace are made

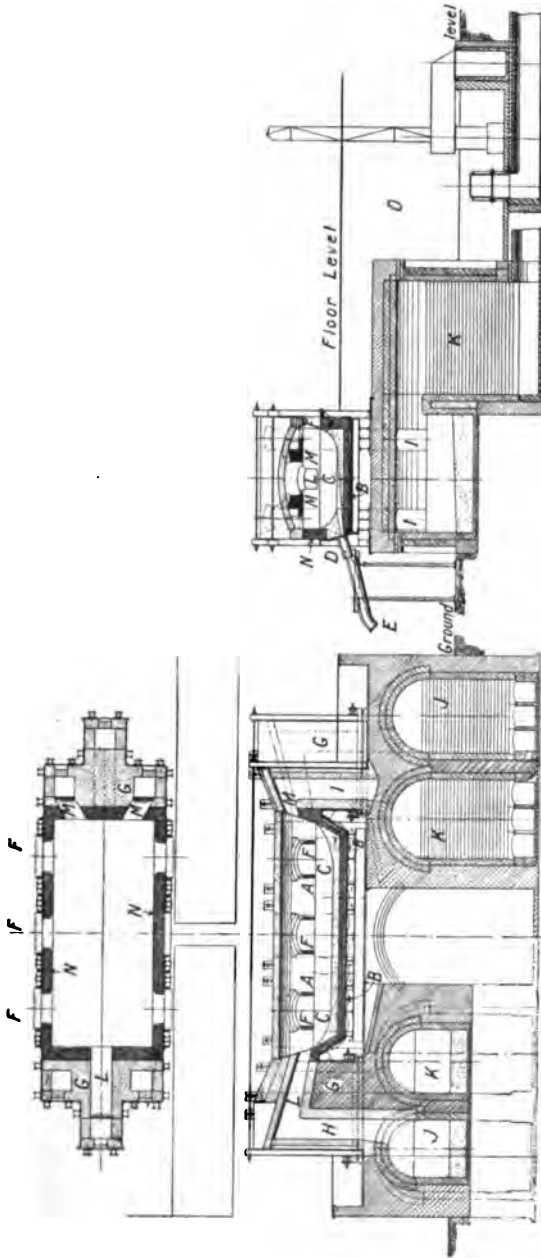

FIG. 38.—Siemens "Open-Hearth" Furnace.

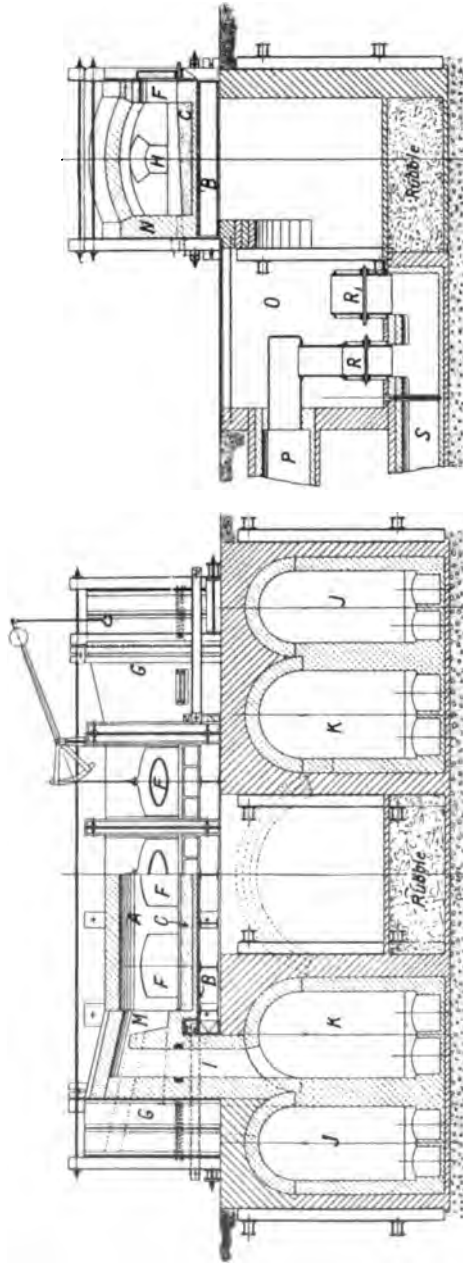
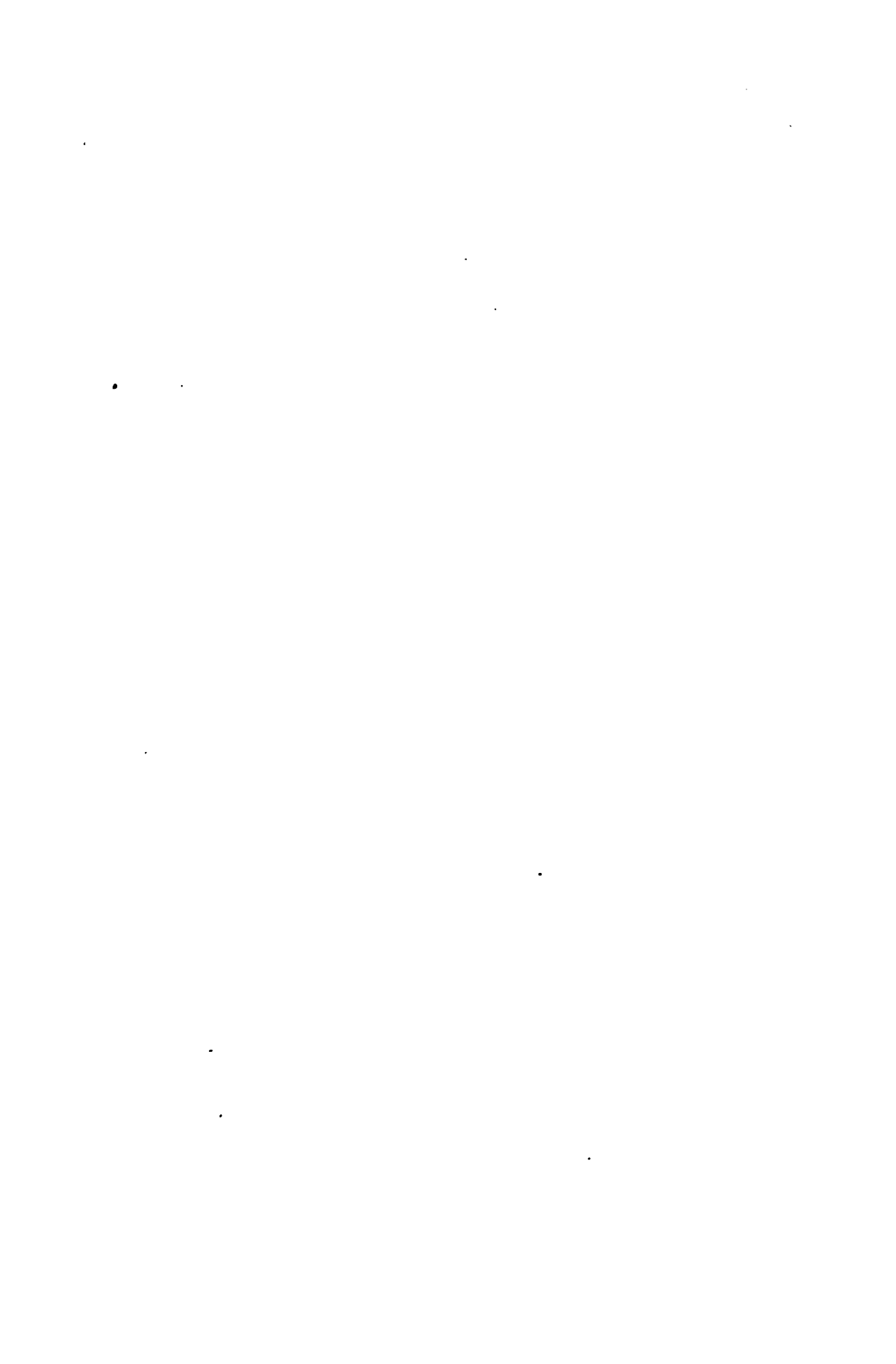
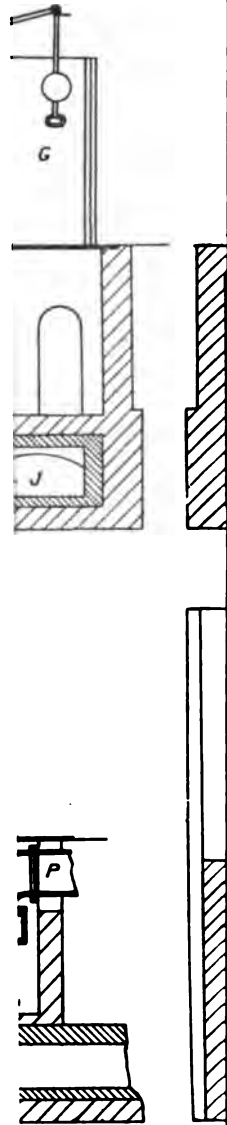

FIG. 39.—Siemens "Open-Hearth" Furnace.





-Diagram of Siemen

from 4 to 6 feet thick, as in them have to be formed the flues or passages, H, I, from the regenerators, J, K. These passages are turned horizontally, and open into the furnace through *ports*, three in number, arranged in two rows. The gas enters through one of these ports, L, placed at the level of the doors, the remaining two, M, which are placed above, serving to admit the air, at about the level of the roof. The side walls, N, of the furnace are about 15 inches thick, and are enclosed in steel plates supported by buckstaves of rolled joist or rail section connected together by tie-rods. Below the furnace are placed the *regenerators* arranged in two pairs, the gas and air being heated in separate chambers, J and K respectively, each filled with a chequer work of firebrick. The pairs of regenerators are heated alternately by conducting through them the hot gases from the furnace on their way to the chimney. The heat absorbed by the brickwork in this way is afterwards given up again to the air and gas on their way to the furnace. The method of reversing the direction of flow through the regenerators is shown in the diagram Fig. 40, to which also reference may be made in connection with the previous figures. Separate valves, placed in the cave, O, immediately in front of the furnace and below the floor level, are provided to adjust the supply and control the direction of both air and gas. The gas enters from the culvert, P, through the *inlet* or mushroom valve, Q, which regulates the quantity passing, and then through a *butterfly reversing valve*, R, which can be turned over to direct the flow into either of the gas regenerators. A similar arrangement of admission and reversing valves is employed for the air, which is thus conducted to one or other of the air regenerators. After traversing their respective regenerators, the air and gas enter at one end of the furnace by way of the ports already described, and the resulting flame and waste gases pass out at the same time through the ports in the opposite end, and are drawn down through the other pair of regenerators into the flue, S, leading to the chimney. The direction in which the air and gas pass through the regenerators is reversed about every half hour, thus maintaining the brickwork at a very high temperature. In this way the heat produced by the combustion of the gas is added to that taken up from the regenerators, and the furnace is filled with flame of intensely high temperature. By varying the proportion of air to gas, the

flame may be made reducing, neutral, or oxidising at will, giving great facility in controlling the various stages of the process. The regenerative system of working has enabled very considerable economy in fuel to be effected, as compared with the ordinary furnace. The temperature of the products of combustion on leaving for the chimney does not much exceed 300° F., proving that the heat generated is almost entirely retained in the furnace and regenerators. The working capacity of the Siemens furnace has been increased in recent years from 10 up to 50 tons or even more, the most economical and most easily managed size being probably about 25 tons. In working the Siemens open-hearth process, the charge of pig iron is distributed over the bed of the furnace, and a quantity of steel scrap, such as rail ends, shearings, etc., is added. When completely fused, pure hematite iron ore in lumps is added at intervals to effect the oxidation of the silicon, carbon, and manganese of the pig iron, the bath of molten metal being caused to boil violently from the escape of carbonic oxide, as in puddling. To melt a 25 or 30-ton charge, the time taken is four or five hours, a "short, sharp" oxidising flame being employed. If a hard steel for rails is required, the metal will be tapped soon after boiling has subsided, but for softer metal the heat will be prolonged, extending to eight or ten hours. This permits of perfect control over the process, and constitutes the great advantage of open-hearth working. Samples are taken from time to time with a long spoon-like ladle, and are tested for malleability and toughness, the fracture being examined, and the percentage of carbon rapidly ascertained by chemical analysis. When the carbon has been sufficiently reduced, say to 0.1 per cent., the metal is allowed to stand awhile, and the temperature is increased, to keep it fluid and clear out the slag. Spiegel is then added, and the furnace is *tapped* by driving an iron bar into the taphole. As the metal runs out, a small quantity of ferromanganese previously heated to redness is added in the ladle, T (Fig. 40), which is of the same construction as that used in the Bessemer process. The ingot moulds, U, are placed in a row in the casting pit, V, which is usually arranged parallel to the length of the furnace at the rear or tapping side, and along which the ladle, mounted on a bogie, may be run on rails to bring it over the moulds in succession. Immediately below the taphole is the

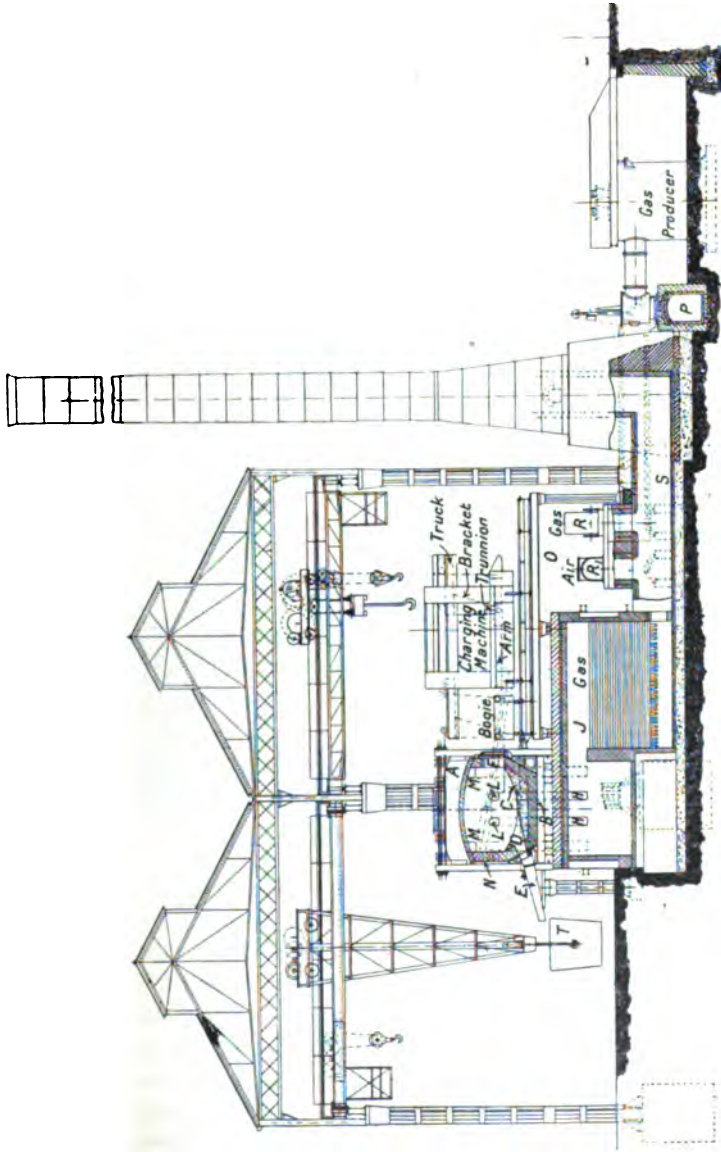

FIG. 41.—Charging Machine for Open-Hearth Furnace.

slag pit, W, so that after the whole of the charge has been run off into the ladle, the lander may be removed, and the slag allowed to flow into the tub, X, carried on a bogie. The Siemens open-hearth process is more costly in operation, and the rate of production is less than the Bessemer, but any pig-iron free from sulphur and phosphorus may be employed, with the further advantage of using up large quantities of scrap by remelting. The great point in favour of the open-hearth acid process is that perfectly uniform composition of the steel produced may be ensured.



FIG. 42.—Charging Bogie for Steel Furnace.

The *basic open-hearth process* is carried on in a Siemens furnace lined with dolomite, lime being added to the charge to keep the slag strongly basic. Phosphoric pig may be thus treated in a manner similar to the basic Bessemer process.

Modifications of the Siemens Process.—The modern tendency to work with very large charges of 50 or even 100 tons has been responsible for the introduction of two important improvements. The difficulty of working heavy charges has been overcome by the use of *charging machines*, of which the Wellman, Fig. 41, is the best known. The author is indebted to Messrs. Wellman-Seaver and Head, Ltd., of London, for drawing and illustrations

of their electric open hearth charger referred to in the following description. The charge is placed in boxes capable of holding about a ton of pig iron, scrap, or ore. Four of these boxes may be carried on the charging bogie shown separately in Fig. 42, which runs on a narrow-gauge line close to the front of the furnace. A second set of rails outside the first and about 12 feet gauge is provided for the charging machine itself, which is mounted on wheels, and is operated in all its motions by electric motors, taking current from a trolley-wire overhead. Fixed to the frame of the machine at the top are two girders which project close



FIG. 43.—Charging Machine for Steel Furnace.

up to the front of the furnace, and which carry a four-wheel truck running on rails after the manner of an overhead travelling crane. Projecting downwards from the truck is a strong arm or bracket, with a trunnion bearing at its lower end in which the *charging bar* rotates. A platform is slung from the charging bar for the man operating the machine, who is thus in a position to see the charge deposited in the furnace. By means of motors of about 25 H.P. the charging bar may be raised or lowered bodily, or moved right or left, and a smaller motor of $3\frac{1}{2}$ H.P. is employed to rotate the bar for the purpose of emptying the boxes. The latter are provided with sockets into which a flange on the end of the charging bar fits, and passing through

the charging bar, which is hollow, is a locking bolt actuated by a lever for securing the box in position. The bogie with the charging boxes is placed in front of the machine, and the end of the bar is lowered into the socket on one of the boxes, which is then locked upon the bar. The whole is raised, and with the truck, is run forward on the upper girders of the machine to bring the box inside the furnace to the spot where the charge is to be deposited. The bar is then rotated, turning over the box and allowing its contents to fall into the furnace, when the truck is run back to withdraw the box, which is replaced on the bogie



FIG. 44.—Charging Machine for Steel Furnace.

and released by drawing back the bolt. The whole operation of lifting, discharging, and replacing the box occupies about a minute, and in this way some 50 tons of material may be charged into the furnace in an hour, with a very considerable saving in labour. Fig. 43 shows a machine of the overhead crane type, installed at the Britannia Works of Messrs. Dorman, Long & Co., Ltd., Middlesbrough. In this view, the machine, which is operated by six electric motors, is slewed round away from the furnace, just after picking up a loaded box containing 4 tons of pig iron. Fig. 44 shows the lower part of the trolley with the motors and the driver's platform, and the charging arm in the lowest position.

A second difficulty incidental to the working of large furnaces is that of tapping a very heavy charge. This has been overcome

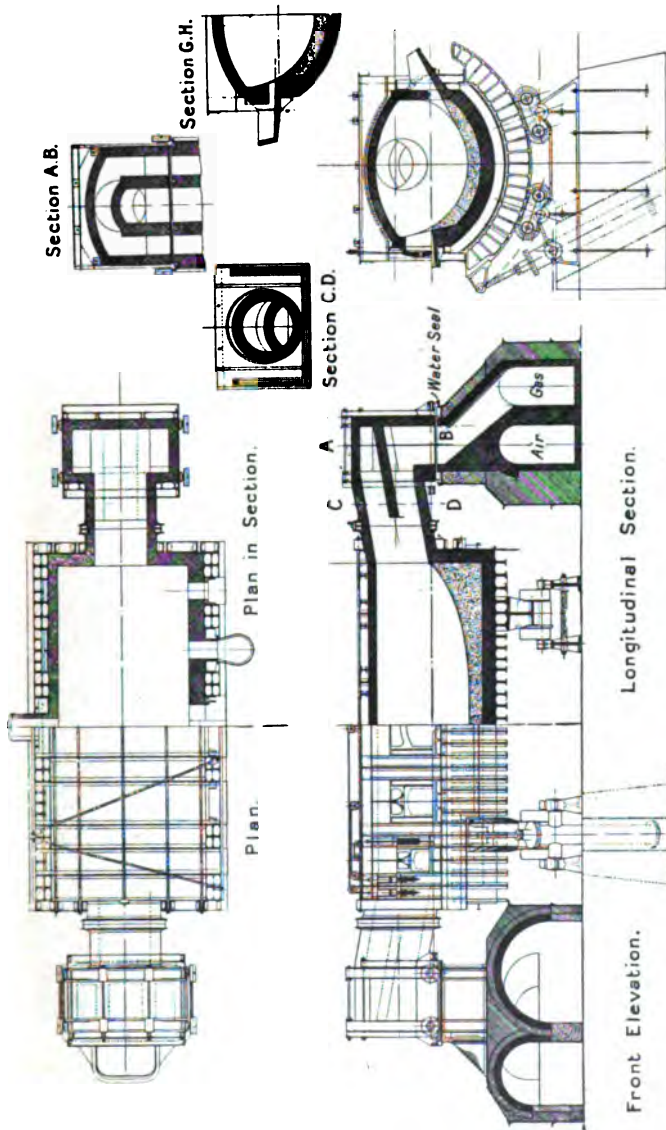

FIG. 45.—Talbot Tilting Furnace for continuous working.

by the employment of the *tilting or rolling furnace*, the body of which is carried on strong girders of curved form, so that the

furnace may be rocked bodily by means of hydraulic rams. This enables the metal to be poured from a spout, and as pouring may be started or stopped at any moment, the loss of time in tapping through a tap hole in the usual way is avoided. Slag



FIG. 46.—Talbot Furnace at work.

may also be drained off during the working, if required. The outcome of this idea has been the introduction of *continuous working*, the best known example of which is probably found in the *Talbot Furnace*, Fig. 45, constructed by Messrs. Wellman-Seaver and Head, Ltd., London. At the commencement of the

THE SIEMENS OR OPEN-HEARTH PROCESS. 87

week's work, the furnace is charged with pig-iron and steel scrap, which with additions of ore and lime is converted into steel of the desired quality in the ordinary manner. About one-third of the



FIG. 47.—Talbot Furnace tilted for pouring.

metal so produced is then poured off into a ladle by tilting forward the furnace, and is distributed into ingot moulds as previously described. The furnace is rolled back, and after adding a quantity of oxide of iron to the slag in the furnace, molten pig-iron is run in from a cupola to replace the steel taken out. A vigorous boiling

action resembling the Bessemer blow now commences, due to the discharge of large quantities of carbonic oxide, which burns with an intensely hot flame. The heat evolved being sufficient to raise the temperature of the bath, gas is cut off from the furnace during this period. At the end of ten to fifteen minutes, the slag, which has been deprived of its iron oxide, is partly poured off, and the bath reduced to steel of the required quality by fresh additions of ore and lime. When this has been effected about one-third of the charge is again poured off, and so the process is repeated again and again, the furnace being emptied only at the end of the week. Fig. 46 is from a photograph of a furnace of this type when at work. The port ends are mounted on wheels, and are fitted with a water seal (seen in Fig. 45) so that they may be moved laterally a short distance before tilting the furnace, the supply of gas and air being first cut off. Fig. 47 shows the furnace tilted for pouring.

Another important improvement consists in dispensing with the ordinary ladle, or rather, in attaching the ladle direct to the taphole on the side of the furnace. This is known as the *fore-hearth*, and it is clearly seen at the rear and near the top of the furnace in Figs. 46 and 47. It is constructed of steel plate lined with firebrick, and is provided with two pouring holes and stoppers of the same pattern as those used for an ordinary ladle, so that the metal may be tapped direct into ingot moulds, with a great saving in time and with much less cooling than when a ladle is used. It will be noticed that the molten metal only enters the forehearth when the furnace is tilted, and for pouring off the slag the forehearth is easily removed and a spout substituted.

The continuous method has now been extensively adopted, and amongst other striking examples, a large furnace of 100 tons capacity, which has been installed at the Frodingham Steel Works in Lincolnshire, is producing 650 tons of ingots per week from liquid pig-iron only, without scrap. In this way it is being sought to bring the output of the open-hearth up to that of the Bessemer process without sacrificing facility of control.

Gas Producer.—An important part of the plant required for the open-hearth or Siemens process, is that for supplying the large quantity of gas with which the furnace is fired. Such gas, known as *producer gas*, is made by passing air and steam through a thick layer of incandescent fuel, the oxygen of the air being

converted into carbonic oxide, and the steam decomposed, with the production of hydrogen and carbonic oxide. The gas also contains some carbon dioxide, together with the nitrogen of the air and the volatile hydrocarbons evolved in the distillation of the burning fuel. Three types of producer have been evolved, viz.: (1) The grate or "bar bottom" producer, as originally introduced by Siemens, the use of which has been practically abandoned on account of the difficulty of keeping the bars clear, and of the loss of fuel falling into the ashes. (2) The cupola, or "solid bottom" producer, of which the Wilson is one of the best known examples. The disadvantage of this type is the frequent

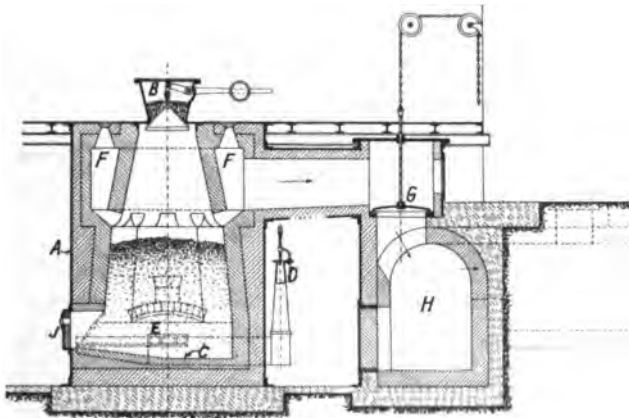

FIG. 48.—Wilson Gas Producer.

stoppage necessary for cleaning out ashes, etc. This has been overcome in (3) the "water bottom" producer, which is built on an iron ring, dipping into a shallow trough containing water, to act as a seal. The ashes thus fall into water, and can be raked out below the casing, no heat being lost. The Wilson producer, Fig. 48, or some modification of it, has been very extensively adopted. It consists of a cylindrical shell, A, of steel plates, lined with firebrick, and having a hopper, B, at the top through which the fuel is charged. The hearth, or bottom, C, is also of brickwork, without grate bars. The air necessary for combustion is forced in by a steam jet blower, D, through the distributor, E, or flue of brickwork in the centre of the hearth. The gas passes through ports into a circular passage, F, round the upper part of

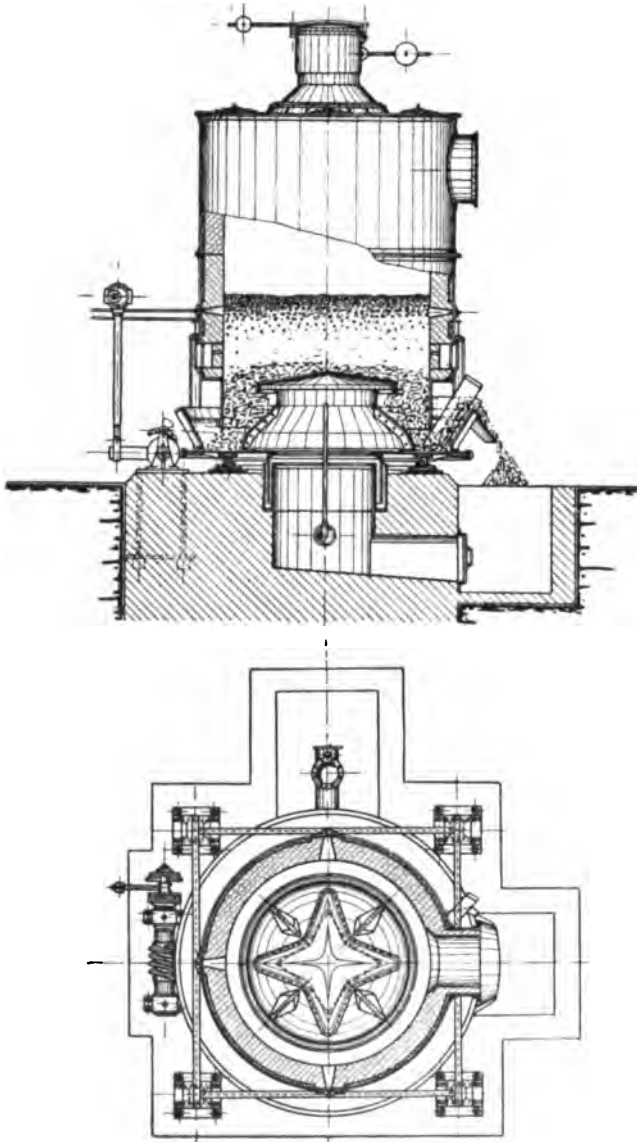

FIG. 49.—Section of "Hilger" Gas Producer.

the producer, from which it is conducted by the downtake to the gas culvert, H, leading to the furnaces. One advantage of the gas producer is that inferior kinds of fuel may be utilised, washed coal slack being generally employed. Slow combustion is maintained by the oxygen of the air blown in through the red-hot fuel at the bottom, carbon dioxide CO_2 being formed, which



FIG. 50.—External View of "Hilger" Gas Producer.

rising through the mass of incandescent fuel above, is reduced to carbonic oxide CO , thus: $\text{C} + \text{O}_2 = \text{CO}_2$, and $\text{CO}_2 + \text{C} = 2\text{CO}$. The steam is also decomposed in passing over the incandescent fuel, thus: $\text{C} + \text{OH}_2 = \text{CO} + \text{H}_2$. The best proportion of steam to air would appear to be about 1 to 20. As the fuel chamber is always kept quite full, the volatile hydrocarbons distilled from the freshly-charged fuel are compelled to pass downwards through the burning mass below, and in this way

tarry matter is decomposed. Inspection doors are provided round the top of the producer and at the side, the latter also serving for the introduction of bars for breaking up the fuel and clinker. The ashes are withdrawn through cleaning out doors, J, about every twelve hours, and a valve, G, is fixed in the downtake to shut off the producer when cleaning, or for repairs.



FIG. 51.—“Pilgrim's Step” Mechanism for “Hilger” Gas Producer.

As already mentioned, the usual form of solid bottom producer entails some difficulty in cleaning out ash and clinker. This has been overcome in the “Hilger” producer, Fig. 49, constructed by Messrs. D. Hunter & Co., of Leeds. The shell is of the ordinary cylindrical form, lined with firebrick, but without water-jacket, and is provided with a double-closing charging hopper at the top. The body of the producer is carried upon a framework

of steel girders and columns (Fig. 50), so as to leave a clear space at the lower end. In this space is arranged a pan-shaped hearth, capable of being rotated on a ring of balls by means of worm gearing. A double-acting ratchet, or "pilgrim's step" mechanism, Fig. 51, imparts to the worm a forward and backward rotation alternately, the amount of which is capable of adjustment in either direction. This enables the quantity of ash thrown out by the stationary shovel (see Fig. 49) to be regulated. Upon the rotating hearth is fixed a star-shaped grate carrying a similar star-shaped upper portion, the blast opening being formed between them, as will be evident from the plan Fig. 49, which shows the grate as seen from above. The ash in the producer is kept constantly in motion by the to-and-fro rotation of the hearth and grate, thus preventing the formation of clinker. If the forward and backward motions are adjusted so as to be equal, the removal of the ash may be stopped entirely, while still subjecting the contents of the producer to considerable agitation. In this way, when using a fuel poor in ash, or when not working to full capacity, it is not necessary to stop the rotating movement, as is the case with producers having grates which rotate in one direction only. The constant returning of the ash and fuel in the Hilger producer brings new surfaces into contact with the blast, with the result that gasification is much hastened.

The average composition of gas from a Hilger producer, and of ordinary coal gas for comparison, is as follows:—

—	Producer Gas.	Coal Gas.
Carbon Monoxide	29 per cent.	7½ per cent.
Carbon Dioxide	3¼ "	—
Hydrogen	13 "	47½ "
Marsh Gas	1⅞ "	41½ "
Hydrocarbons	—	3¼ "
Nitrogen	52 "	—
Combustible Gases	44 "	100 "

Complete Plant for Steel Making.—An ideal arrangement of steel-making plant, to which, however, it is not always possible to conform in practice, is shown in Fig. 52, due to Mr. J. E.

Stevenson, of Middlesbrough. The blast furnace, A, worked in conjunction with the hot blast stoves, B, supplies molten cast iron to the metal mixer, C, from which it is taken as required direct to the tilting furnace, D. The open-hearth steel so produced is tapped into ingot moulds, E, which, when the metal is sufficiently solid, are stripped by the crane, F, the ingots being at once transferred on bogies to the soaking pits, G. After heating uniformly to the proper temperature for rolling, the ingots are lifted out by the crane, H, and carried on live rollers, I, to the cogging mill, J. Here they are reduced to blooms, slabs, or billets of suitable size and section for subsequent treatment.

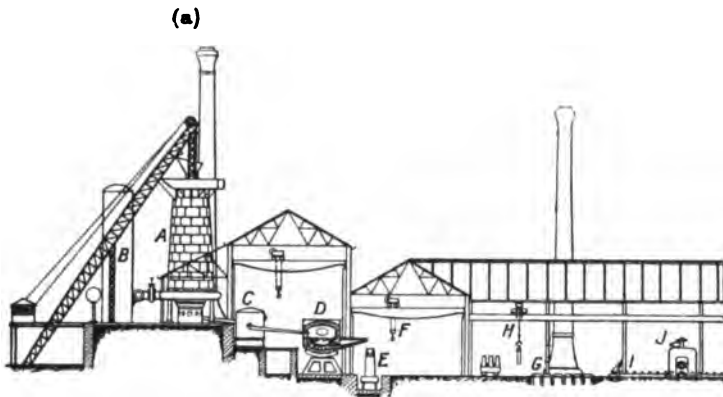

FIG. 52.—Continuous Steel-making Plant.

From the cogging mill the steel proceeds to the roughing rolls, in which it receives approximately the shape of section desired, and then finally to the finishing rolls, in which it is brought down to exact dimensions. The great difference in the treatment of wrought iron and steel will be noticed. The cutting up, piling, re-heating, and welding, necessary for wrought iron is not required for steel. With the latter, the ingot, no matter by which method it may be produced, is subject to a continuous process of rolling only, usually without re-heating. The process of reduction from the ingot to the finished section is well illustrated by reference to Figs. 448, 449 and 450, in which are shown the form of the rolls and the number of grooves or passes required in rolling out a tramrail, Fig. 448 being the cogging,

Fig. 449 the roughing, and Fig. 450 the finishing rolls for this purpose.

Defects in Casting Steel.—Ingots produced by pouring steel into moulds necessarily much colder than itself are always found to be more or less unsound, and it may be said that the milder the steel the more pronounced the defects become. It is found that molten steel dissolves or occludes a considerable quantity of gas, consisting principally of hydrogen and nitrogen to the extent of 85 and 15 per cent. respectively. These gases are given out very largely during solidification, but are liable to remain imprisoned in the form of bubbles of very irregular size and shape as at B, Fig. 53, giving rise to *blowholes* and *honeycombing*. The ingot also contracts considerably on cooling, and as solidification commences at the surface of the mould, a conical depression at the top, or a hollow cavity in the interior, may be formed as at P, Fig. 53. This is known as *piping*, and its existence is most marked in the harder grades of steel. A third defect is that known as *segregation*, or the tendency to separate into portions of different composition, due to the fact that the various constituents of the steel possess different degrees of fusibility, some remaining liquid after the rest have solidified. The action is thus similar to that of a salt in expelling the mother-liquor when crystallising. Hence, as slow cooling is productive of segregation, rapid solidification is desirable as securing homogeneity.

Several methods have been proposed for overcoming the above defects with a view to producing sound ingots. The addition of silicon, in the form of silico-ferromanganese, immediately before pouring the metal into the moulds has long been known to yield good results, and more recently it has been found that a small quantity of aluminium, introduced in a similar manner, has a

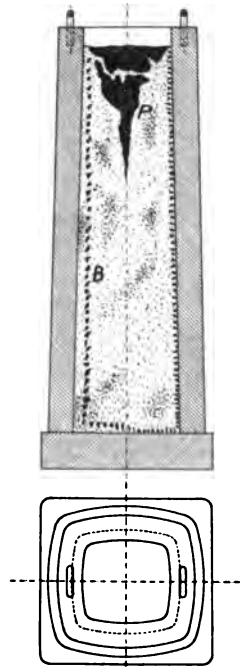

FIG. 53.—Section of Steel Ingot and Mould.

very marked action in assisting to produce sound castings. An important process for consolidating steel ingots by subjecting the metal to hydraulic pressure while in the fluid state was introduced by Sir Joseph Whitworth in 1865, and has since been employed in the production of the celebrated Whitworth *fluid-compressed steel*, largely used in the manufacture of ordnance and heavy marine shafting. Other methods of compression have been devised, but the process is at best somewhat difficult of practical application, and the use of a *sinking head* (pages 245 and 259) is still commonly resorted to. The mould is made about 25 per cent. longer than the size actually required, so that the metal

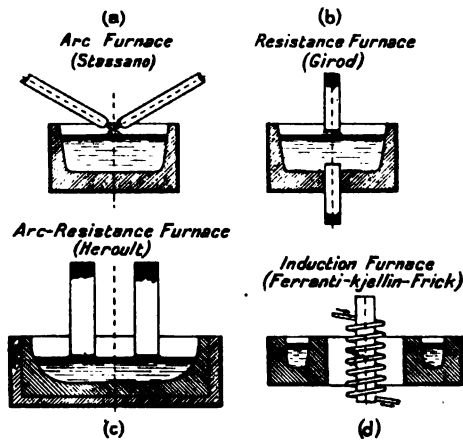

FIG. 54.—Types of Electric Smelting Furnaces.

comprising the true ingot solidifies under the pressure due to the head above. The portion forming the head is largely honey-combed, due to the bubbles of gas which rise into it, and is usually found to contain the pipe. It is afterwards cut off and scrapped for remelting, the ingot proper thus remaining comparatively sound.

Electrothermic Manufacture of Steel.—This is an important process of great promise in the future, in spite of the high cost of the electric current and of the electrodes used to convey it to the molten metal.

The electric furnace for the manufacture of crucible cast steel and for the preparation of alloys of iron with other metals, such as nickel, chromium, tungsten, vanadium, etc., undoubtedly

possesses great advantages over the older processes. Hitherto its use has been confined to localities where water power is available for the production of the necessary current, but the utilisation of blast furnace gas in large-power gas engines driving electric generators should admit of its adoption in any large steel-works.

The advantages of the process are (1) that any desired temperature may be maintained and controlled with the greatest ease, and (2) that the introduction of impurities inseparable from the use of solid or even gaseous fuel is avoided.

Electric furnaces are of three types, Fig. 54: (1) Arc furnaces (A); (2) resistance furnaces (B) and (C); and (3) induction furnaces (D), according to the method employed for converting the electric energy into heat.

The best example of the *arc furnace* is that of Stassano, Fig. 55, which takes the form of an iron-clad circular chamber with dome roof, the whole lined with refractory material. Through the side project two or three adjustable carbon electrodes, between which the arc is formed. The charge is melted by the heat radiated from the arc, and the molten metal is set in motion and thoroughly incorporated by causing the whole furnace to revolve. Tap holes are, of course, provided for the removal of the metal and

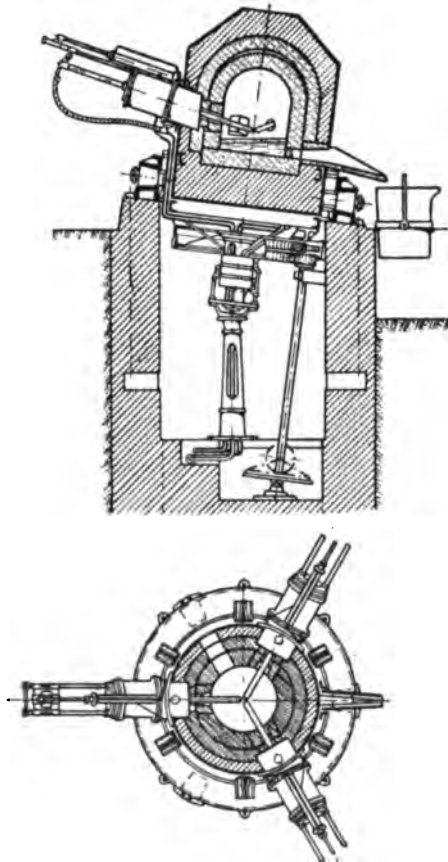

FIG. 55.—Stassano Furnace.

the slag. The arc furnace is said to be capable of producing a temperature of 7000° F., and is especially suitable for any operation requiring a high temperature.

The most successful form of *resistance furnace* is probably the Hèroult, Fig. 56, which in construction closely resembles the open-hearth tilting furnace already described. The charge, consisting of pig iron with the addition of steel scrap, is melted on the hearth of the furnace and is treated in all respects as in the open-hearth process, except that heat is produced by electrical means instead of by burning gas. The source of heat is the resistance offered to the passage of the electric current in traversing the bath of molten metal. The electrodes are not,

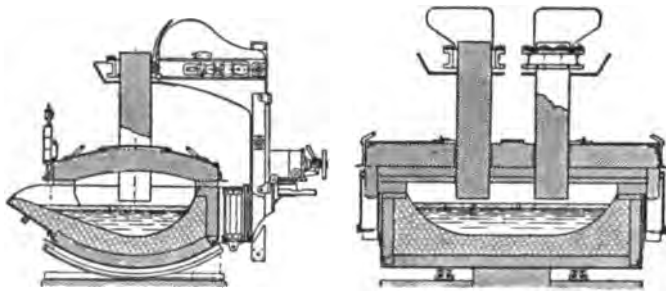

FIG. 56.—Hèroult Furnace.

however, brought into actual contact with the bath, but an arc is formed from the positive electrode to the bath, through which the current passes, causing a second arc to the negative electrode.

The *induction furnace*, first proposed by Ferranti, is constructed upon the principle of the transformer, or induction coil. A successful example is that of Frick, Fig. 57, employed on a large scale at Krupp's works in Essen, and recently by Messrs. John Brown & Co., Ltd., and Messrs. William Jessop & Sons, Ltd., of Sheffield. The hearth of the furnace is a ring-like or annular channel left in the body of refractory material, and fitted with a movable cover. The core of the transformer is laminated, and is built up of soft iron plates insulated from each other. The core is approximately rectangular, forming a closed magnetic circuit, one limb of which, surrounded by the primary

coil of many turns of insulated copper wire, passes down vertically through the space at the centre of the hearth. The secondary

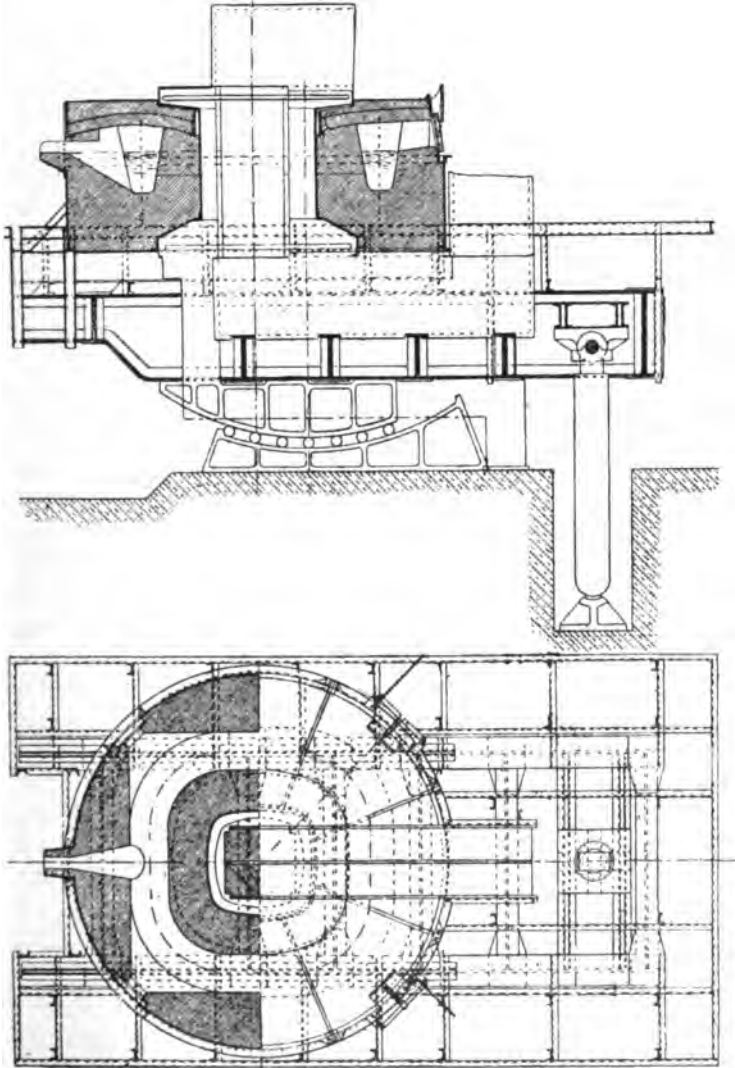

FIG. 57.—Frick Furnace.

circuits is formed by the ring of molten pig-iron, which is first run into the hearth, when the furnace becomes a transformer.

An alternating current of 80 ampères is supplied to the primary at a pressure of 3,000 volts, and the number of turns in the coil is so arranged that a current of 30,000 ampères at a pressure of 7 volts is induced in the secondary. The great resistance offered to the passage of this heavy current sets up a considerable heating effect, the action being one of melting only. The charge of pig-iron and scrap in proper proportion can thus be melted down to give steel of any required composition. A furnace having a capacity of 10 tons has a power consumption of 1,000 H.P., and the efficiency of the different stages is stated to be:—Gas engine, 30 per cent. ; alternator, 91 per cent. ; electric furnace, 82 per cent. ; total efficiency of electric melting, 22 per cent.

CHAPTER X.

ALLOYS.

THE properties of any one metal may be considerably modified by the addition of a small quantity of another element, and in this way it is often possible to improve the quality, or remove some defect, which may exist in the purer metal. It may, for instance, be desired to bring about any of the following objects : (1) to produce sound castings ; (2) to lower the melting point ; (3) to increase the hardness ; (4) to increase the strength and toughness ; (5) to resist oxidation or corrosion ; (6) to improve the appearance, either as regards colour, or ability to take a high polish. For such purposes, one metal is frequently added to another, the result being known as an *alloy*. Viewed in this light, cast iron may be regarded as an alloy of iron and carbon, which becomes more and more difficult to melt and to cast with each reduction in the proportion of carbon below 2 per cent. Copper alone is extremely difficult to cast, but the addition of zinc enables sound castings to be produced quite readily. Gold and silver for coinage must be hardened by the addition of a small quantity of copper. The strength of copper is greatly increased by alloying with tin. The appearance of gold may be closely imitated by adding aluminium to copper, and even a deep violet colour may be obtained by alloying equal parts of copper and antimony.

All substances other than chemical elements are classified either as chemical compounds or mechanical mixtures. It is well known that elements can combine only in certain fixed proportions to form compounds. In the production of alloys, however, the constituent metals need not be present in definite chemical proportion, and in fact, it will frequently occur that two metals will alloy equally well in widely differing proportions.

The modern theory of the constitution of alloys has been built up very largely from the work done by the late Sir W. C. Roberts-Austen for the Alloys Research Committee of the

Institution of Mechanical Engineers. The reports will be found in the Proceedings of that body for the years 1891, 1893, 1895, 1897, 1899 and 1904, and together with several important papers which were read before the Institute of Metals in 1908 (see *Engineering*, Nov. 20th, 1908), may be consulted by the reader with advantage, as only a brief outline of the subject can be attempted here.

Almost all metals mix well together when melted, but on solidifying, the difference in density or in fusibility may tend to bring about a separation to a greater or less extent. Melting at too high a temperature, and slow cooling, are each particularly liable to increase any tendency to separation. It cannot therefore be said that alloys are chemical compounds. On the other

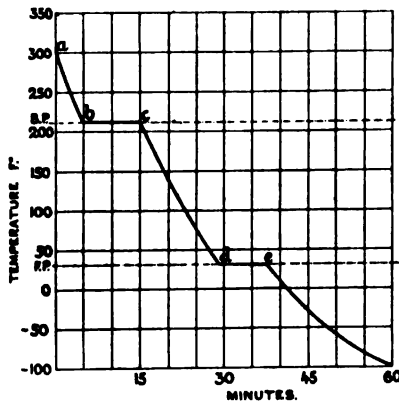

FIG. 58.—Freezing Curve of Water.

hand, it is characteristic of a mechanical mixture that the smallest particles of each of the substances composing it retain their original properties unimpaired. Hence, any property of a true mechanical mixture, specific gravity for instance, will be simply a mean of the properties of its components. Alloys do not, however, follow this rule, and are frequently found to possess properties

differing considerably from those of their constituents. According to the modern theory of the constitution of alloys, they are to be regarded as "solid solutions" of one metal in another, or it may sometimes happen, of a definite chemical compound of the metals in the metal which is in excess. In this light, the structure of an alloy is very similar to that of an igneous rock, such as granite, which is built up of widely differing constituents, viz., felspar, quartz, and mica. These exist in the form of crystals, cemented together by the solidified "mother-liquor" from which the crystals were deposited during cooling. It is therefore necessary to study the phenomena which occur during the cooling and solidification of a single substance and also of a solution. This is best shown by means of a diagram in which

ordinates represent temperatures, and abscissæ times of cooling. The "freezing curve" of water, in Fig. 58, is taken to commence with steam which cools down from *a* to *b* at a regular rate to 212° when condensation commences, and the temperature remains constant during *bc* minutes. At *c*, condensation is complete and the temperature again falls regularly to freezing point from *c* to *d*. Solidification then commences, and the temperature remains constant at *de* until the whole mass has become solid, after which it will continue to fall so long as further cooling of the ice proceeds. With a single substance, the melting or freezing point, as the case may be, is fixed and invariable, and in changing from the solid to the liquid state, or *vice versa*, the temperature is always arrested at this point until the change is complete. Proceeding next to consider the behaviour of a solution, it is instructive to note what happens when a solution of common salt in water is frozen. It is well known that a solution always freezes at a lower temperature than the freezing point of the solvent, the "depression" of the freezing point depending upon the quantity of the substance in solution. Suppose, Fig. 59, a

solution of 10 per cent. of salt in water is cooled down slowly by some external agency. At a temperature of 21° , solidification commences, ice free from salt being first formed. The temperature now falls more slowly as solidification continues, and a small quantity of salt separates with the ice, causing the remaining mother-liquor to become more and more concentrated. Hence the freezing point is continuously lowered, until at -8° F. solidification is complete. A solution has therefore no definite freezing point. The temperature at which solidification commences, known as the initial freezing point, depends upon the quantity of matter in solution, but the second freezing point, when solidification is complete, always remains constant whatever the strength of the solution may

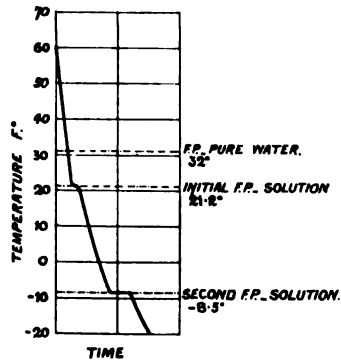

FIG. 59.—Freezing Curve for Solution of Salt.

be. Thus, for a solution of salt in water, the lower freezing point is always -8°F . The portion of a solution which is the last to solidify at the lower freezing point is termed the

eutectic, and it has always a certain definite composition. In the case of salt and water, for instance, the eutectic always contains 23.5 per cent. of salt, and in freezing, the crystals of ice and of salt are simply mixed in very close contact.

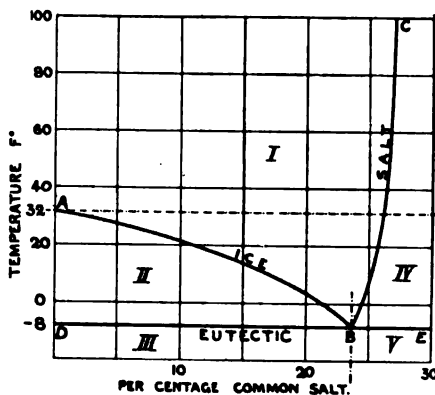

FIG. 60.—Freezing Point Curve for Salt Solutions.

diagram, for ice (AB), salt (BC), and eutectic (DE) respectively. Taking a 10 per cent. solution as before, it will be noticed that

freezing commences at 21°F . as shown by the ice line, and is complete at -8°F . as indicated by the line marked eutectic. When the solution contains 23.5 per cent. of salt, both freezing points coincide on the eutectic line at -8°F ., as before explained. The steepness of the salt line is accounted for by the fact that the melting point of salt is 1800°F . Taking a solution which is more highly concentrated than the eutectic, and which contains, for example, 25 per cent. salt, it will be seen from the salt line that

the first solid to separate on cooling is pure salt, at an initial freezing point of 10°F . The second freezing point is that for the eutectic of salt and ice, which always has the same

The freezing point curves for salt solutions of various strengths are shown in Fig. 60. There are three lines in the

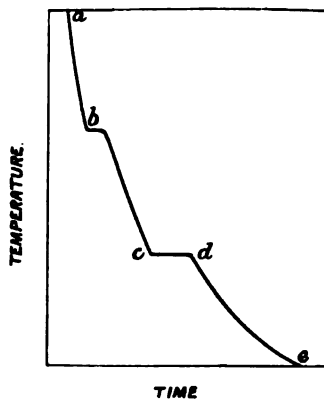

FIG. 61.—Freezing Curve for Alloy.

composition and always freezes at the same temperature, viz., -8° F.

An alloy of two metals will be found to behave in a similar manner, and if a diagram be plotted showing the temperature during the time of cooling down from the molten state, a curve is obtained which, speaking generally, exhibits the same characteristics as Fig. 61. As before, the temperature falls gradually from *a* to *b*, after which, for some little time, cooling proceeds at a less rapid rate, one of the constituents crystallising out at *b*, leaving the liquid portion weaker in that constituent. As the curve *bc* is traced, more and more of this constituent solidifies, the "mother-liquor" becoming correspondingly poorer, until at *c* it begins to solidify.

The temperature now remains constant from *c* to *d*, at which latter point solidification is complete. The further cooling of the solid proceeds gradually, as shown by the line *de*. Distinguishing the two constituents of the alloy as A and B respectively, it may be said that the crystals first deposited

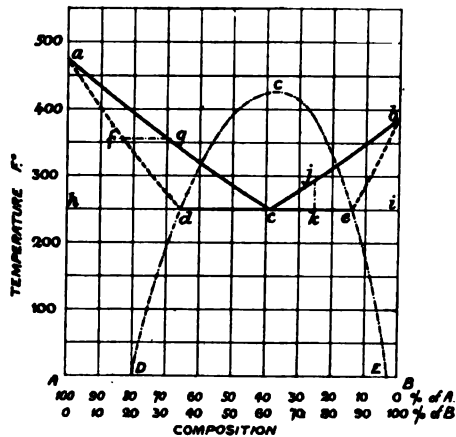

FIG. 62.—Freezing Point Curves for Alloy.

at *b* are of large size and consist entirely either of A or of B, but during the period of freezing, *cd*, the solid formed, *i.e.*, the eutectic, consists of very small crystals of A deposited in juxtaposition with very small crystals of B. No matter what the proportion of A to B in the molten alloy, the eutectic, although by no means a chemical compound, always contains exactly the same proportion of the two metals, and always solidifies at the same temperature. In the molten alloy, the solubility of each metal in the other depends upon the temperature, which, for alloys of the two metals A and B, is shown in the diagram, Fig. 62, in which ordinates denote temperatures of the molten alloy, and abscissæ the percentage of

each metal present. Thus, at a temperature Ah , the alloy would be composed of two solutions, one containing hd per cent., and the other he per cent., of the metal B. An alloy containing more than hd per cent. and less than he per cent. of the metal B must be regarded as consisting of a mechanical mixture, in some proportion, of the two solutions named. As the temperature increases, the solubility of each metal in the other increases, until at C a single solution is formed. In the diagram the melting points of the pure metals are shown at a and b , and of the intermediate alloys by the lines ac and bc , which are "freezing point curves" for the metals A and B respectively, meeting in c on the eutectic line de . An alloy consisting of 70 per cent. A and 30 per cent. B remains in a perfectly fluid condition until the temperature has fallen to the point g at the intersection of the 70 per cent. line with ac , in the diagram. Here crystals of the metal A begin to be deposited, reducing the quantity of that metal in the "mother-liquor." With a further reduction in temperature, more of the constituent A is thrown down, until finally when the temperature is represented by the line hi the whole mass solidifies, A and B crystallising out together in the proportion of ic , $ch = 38$ per cent. and 62 per cent. respectively. Again, from an alloy of 75 per cent. B and 25 per cent. A, crystals of B commence to form at the temperature shown at j , complete solidification taking place at k on the eutectic line as before. Of the critical temperatures, the initial freezing point corresponding to g and j varies with the original composition of the alloy, but the temperature at which the freezing out of the eutectic takes place is constant. In practice, the process here described may be subject to some modification, and it should be pointed out that, in general, each of the metals A and B will crystallise in the liquid alloy with a certain amount of the other dissolved in it, forming, in fact, a solid solution. It will be found that when A commences to crystallise out as at g , Fig. 62, a certain proportion of B, depending upon the temperature at which solidification takes place, is contained in the crystal. This is shown in the figure by the dotted lines ad and bc , which enable the composition of the solid solution formed at any temperature to be read off. Thus, suppose a liquid solution contains 70 per cent. A and 30 per cent. B, by drawing from g a horizontal

cutting the line ad in f , it is found that point f falls on the vertical through 83 per cent. A, and therefore the crystals deposited, instead of containing pure A only, consist of 83 per cent. A with 17 per cent. B in solution. Similarly, the eutectic, as previously mentioned, is seen to consist of a mixture of two solid solutions, one as shown by the point d , containing 34 per cent. B dissolved in 66 per cent. A, and the other represented by point e , containing 14 per cent. A dissolved in 86 per cent. B. Eutectics are not deposited by alloys the composition of which falls to the left of d or to the right of e .

It is seen that the eutectic has a lower melting point than either of its constituents. Hence it exists in the solidified alloy as a network or thin layer surrounding the crystals of the other constituents, and it follows that the strength of the alloy is limited by the strength of the eutectic. As a general rule, therefore, alloys in which eutectics are formed are unfitted for use where strength is required.

From the above considerations, it will be evident that an alloy in the solid state will not be homogeneous, unless the metals of which it is composed happen to be present in exact eutectic proportion. As an alloy cannot have a definite freezing point, the centre of the mass which is the last to solidify on cooling, will also have the lowest melting point. This may be either the solid solution of lowest melting point, or the eutectic, according to circumstances. In the case of a solid solution, the percentage composition will be found to vary gradually from the outside to the inside of the mass. Should the eutectic mixture be the last to solidify in the interior, there will be a sudden change in composition between it and the first portion to solidify on the outside. This separation into portions of different composition is known as *segregation*, and in practice it is often so pronounced as to be readily detected by chemical analysis. Portions which solidify at different temperatures are of different composition, and therefore of different specific gravities, and hence in a casting, such as an ingot, segregation may take place not only inwards but also upwards. Want of homogeneity leads to the development of wide differences in molecular structure, which may result in inducing internal stresses of an injurious character. As a rule, the structure of an alloy after solidification is distinctly crystalline, and the slower the cooling, the larger the crystals are likely to be.

Consequently the crystals in the interior, on account of slower cooling, are usually much larger than those on the outside. A coarse crystalline structure is a certain sign of weakness and brittleness; a fine grain may be taken to indicate strength. Although it may be impossible to obtain homogeneity in an alloy, steps should always be taken to reduce segregation to the lowest limits. It will now be apparent that the more rapid the solidification of the alloy, the more perfect will be the mixture of its constituents, and again, the more rapidly cooling takes place *after solidification has occurred*, the finer the crystalline structure. The properties of an alloy are considerably influenced by differences in

structure, much information concerning which may be revealed by microscopic examination.

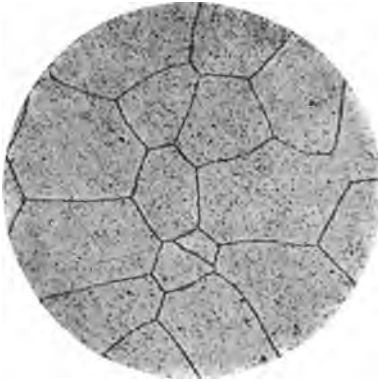

FIG. 63.—Ferrite (Longmuir) $\times 150$.

Internal Structure of Metals and Alloys.—The internal structure of metals and alloys is readily revealed by examination under the microscope. For this purpose, a small “section” of the metal about $\frac{1}{2}$ inch square is prepared, the surface being very highly polished until all scratches

disappear. It is then etched with dilute acid or other suitable medium, which, attacking some of the constituents of the metal more readily than others, brings out or develops the structure. This may be very conveniently examined with a magnification of from 50 to 300 diameters, and by using a camera in combination with the microscope, the image may be projected on a photographic plate, and a negative obtained in the usual manner. The accompanying figures have been produced in this way.

Constitution of Iron-Carbon Alloys.—As previously explained, iron or steel of commerce is to be regarded as an alloy, or as it may now be described, as a “solid solution” of carbon in iron. Iron exists in three forms, known as alpha, beta, and gamma iron respectively, denoted by the Greek letters α , β , and γ . The first form is the only constituent of pure iron, and it has there-

fore been termed *ferrite*. All metals in the chemically pure state are crystalline, and the crystals of ferrite which go to form the mass of a sample of nearly pure iron are clearly seen in the micrograph, Fig. 63. Carbon enters into combination with iron as a definite carbide to which the name of *cementite* has been given, and which is represented by the formula Fe_3C . Cementite is insoluble in ferrite, but a mixture of ferrite and cementite occurring in alternate layers is known as *pearlite*, the polished and etched surface of which exhibits a play of colour resembling mother-of-pearl. This lamellar structure is shown in Fig. 64. At $1400^{\circ} F.$, α -iron changes over to the β -modification, in which also cementite is insoluble, and which has the



FIG. 64.—Pearlite (Stead) $\times 1,000$.



FIG. 65.—Martensite (Stead) $\times 250$.

property of being non-magnetic. When the temperature exceeds $1600^{\circ} F.$, the γ condition is produced, and cementite becomes soluble to a certain extent. A solid solution of carbon or of cementite in γ iron is known as *martensite*, Fig. 65, the name having been chosen as a compliment to the late Professor Martens of Berlin, one of the founders of the science of metallography.

The diffusion of common salt in water bears a strong resemblance to the diffusion of carbon in iron, as will be evident from an inspection of the freezing point curves, Figs. 60 and 66. In one case water, and in the other iron, acts as the solvent, and the part played by common salt in the water solution is analogous to that of carbon when dissolved in iron. Take, for example, mild steel containing 0.2 per cent. carbon in solution. During the period of

cooling down from the molten state to about 1600° F. the steel exists in the form of martensite, a solid condition corresponding to region I. of the liquid water—common-salt solution, Fig. 60. Continuing the cooling below 1600° F., crystals of pure iron begin to separate out from the martensite. These iron crystals correspond to the ice crystals which separate from the water—common-salt solution, and the martensitic condition of the steel resembles the “mother-liquor” in the water—common-salt solution. This iron free from carbon is, as above explained, known in metallography as ferrite, and the separation of the ferrite crystals con-

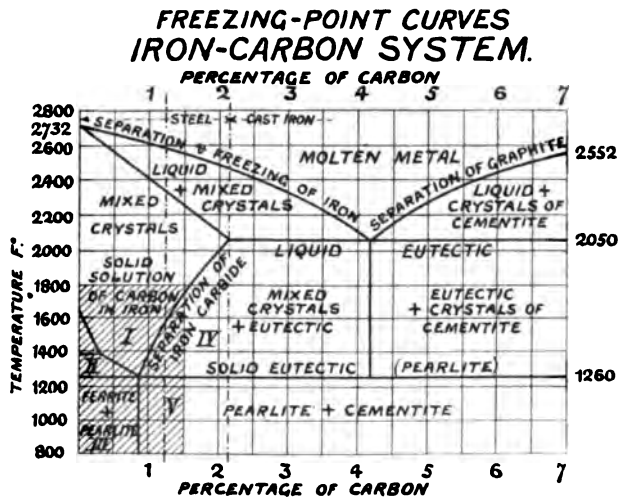

FIG. 66.

tinues on further cooling until the martensite, which originally had a carbon content of 0.2 per cent., has been enriched to 0.9 per cent. carbon. This point corresponds to the proportion of 23 per cent. salt in the “mother-liquor” of the water—common-salt solution, which freezes at -8° F. The solid solution containing 0.9 per cent. carbon is known as the *eutectic*, and this condition is reached when cooling has gone down to 1260° F. At this temperature the substance changes over to the condition termed pearlite, which corresponds to the freezing of the “mother-liquor” in the case of the water—common-salt solution. At temperatures between 1600° and 1260° F., crystals of ferrite are contained in a “mother-liquor” of pearlite. It should be pointed out that the

diagram, Fig. 66, shows the complete history of the iron-carbon system, up to the maximum percentage of carbon which the iron is capable of taking up. But the left-hand corner of the diagram shown shaded is the only portion concerned in the explanation of the phenomena which occur through the range of carbonised irons from mild to hard steel.

Iron-carbon solutions with carbon content up to 0.9 per cent. resemble water—common-salt solutions in possessing three regions which are passed through in succession during the process of cooling down, if this be carried out to a sufficient extent. In region I., Fig. 66, the iron exists in martensitic condition or as

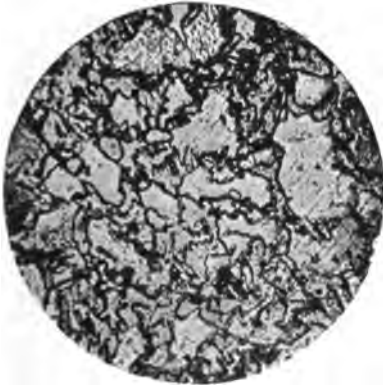

FIG. 67.—Mild Steel (Preuss) quenched at 1400° F.
Ferrite and Martensite ($\times 350$).



FIG. 68.—Mild Steel (Preuss) cooled slowly.
Ferrite and Pearlite ($\times 350$).

a solid solution. This martensite is really the very hard constituent of hardened steel, and the crystals show a peculiar interlacing needle-like structure, seen in Fig. 65. On cooling steel rapidly from a high temperature by quenching, the carbon remains in the form of martensite, and the steel is hard. It is found that if the cooling is effected with extreme rapidity, as by quenching in water mixed with ice, the structure of the metal when cold is practically the same as that which existed at the time of quenching. It is thus possible, by quenching the specimen at the proper temperature, to obtain microphotographs showing the structure possessed by the metal when hot, and in this way it has been demonstrated that the same piece of metal

exhibits wholly different structures at different temperatures. In region II. (Fig. 66), crystals of ferrite are found embedded in martensite, the structure being indicated in the microphotograph Fig. 67. Within region III., for temperatures below 1260° F., ferrite crystals are combined with pearlite, as shown in Fig. 68, in which the white areas represent ferrite, and the darker portions pearlite. With a steel containing 0.9 per cent. of carbon, ferrite does not crystallise out from the martensite, which remains unaltered until the temperature reaches 1260° F., when the whole breaks up into pearlite.

With more than 0.9 per cent. of carbon, as for example, with 1.2

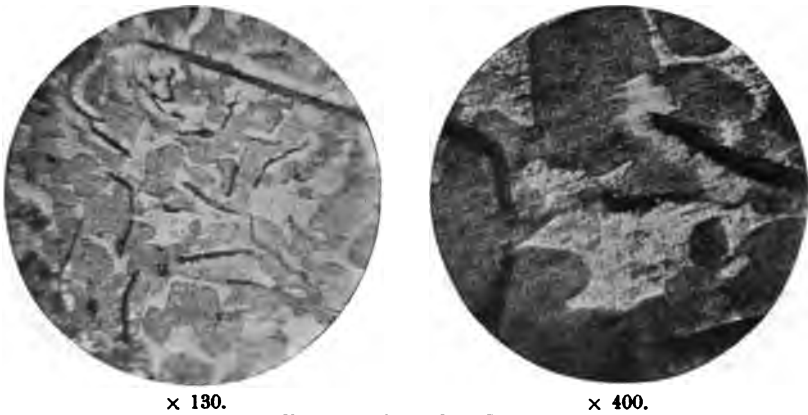

FIG. 69.—Grey Cast Iron.
Flakes of Graphite (black), Pearlite (half-tone), and Ferrite (light).

per cent., solidification takes place over a range of temperature from about 2580° to 2300° F. At temperatures within region I. the steel consists entirely of martensite until it has cooled to 1580° F., when crystals of carbide of iron Fe_3C commence to separate from the solid solution. The carbide of iron, known as cementite, is hard, and does not occur in low carbon steels. The crystals of cementite are found embedded in a "mother-liquor" of martensite. At 1260° F. the martensite changes into pearlite, as before, and hence the normal structure of a high-carbon steel is pearlite and cementite. With the amount of carbon about 2.1 per cent., we reach the maximum limit for alloys usually known as steels, any further increase in carbon producing what are correctly described as cast irons.

If the iron-carbon solution possesses considerably more than 0.9 per cent. of carbon, and if in addition a fairly high silicon content be present, the whole of the carbon does not exist as cementite and pearlite only, but a portion makes its appearance as pure carbon, or graphite. The result is grey cast iron, Fig. 69, in the production of which the influence of some impurity such as silicon is essential. White cast iron is formed when the whole of the carbon is present as a mixture of cementite and pearlite, as will be seen from Fig. 70, in which the white areas consist of cementite, and the darker portions of pearlite.



FIG. 70.—White Cast Iron (Longmuir).
Cementite (white), Pearlite (dark).
× 150.

The microscopic examination of metals and alloys has developed very rapidly in recent years, and is now recognised as an important branch of the science of metallography, to which as a separate subject the reader must be referred.

CHAPTER XI.

SPECIAL OR ALLOY STEELS.

THE addition of comparatively small quantities of certain elements to mild steel has resulted in the production of a number of alloys of considerable commercial importance. The chief of these alloys, which are named after the added metal, are the following :—

Nickel Steel for structural purposes contains about 0·25 per cent. of carbon and 3·50 per cent of nickel. The valuable property of this material is its high ratio of elastic limit to ultimate strength. Compared with mild steel of the same carbon content, the ultimate strength is increased about 20 per cent., but the elastic limit is about 50 per cent. higher. Its great resistance to fatigue renders it especially suitable for marine shafting, piston rods, etc. It is harder than carbon steel, and has a lower coefficient of friction, and has been largely used for the axles of locomotive engines. The proportion of nickel may be considerably increased, forming valuable alloys for certain special purposes. Thus, an alloy containing 25 per cent. nickel possesses the maximum toughness, and offers the greatest resistance to rusting, corrosion, and burning at high temperatures, and has proved of advantage in the manufacture of boiler tubes, valves for use with superheated steam, valves for internal combustion engines, levers and pins for make and break ignition, and sparking plugs for petrol motors. This steel does not, however, admit of case-hardening, or of hardening in any other manner. For valves or other parts, portions of which are to be case-hardened, the proportion of nickel should not exceed 3 per cent. A nickel steel alloy containing 36 per cent. of the former metal is known as *Invar*, and as it possesses the remarkable quality that its expansion under ordinary changes of temperature is practically zero, it is in great request for measuring instruments and standards of length for everyday use.

Chrome Steel is used for ball races and balls of ball bearings, and in the hardened state, has a crushing resistance of 360 tons per square inch. Chrome steel usually contains in addition some

other element, as nickel, tungsten, or vanadium. A nickel-chrome steel containing 3.25 per cent. nickel, 1.50 per cent. chromium, and 0.25 per cent. carbon, is much used for armour plates, the carbon content on the outside of the plate being subsequently increased to 2.5 per cent. by cementation, or "Harveyising," which, while still bright red hot, may then be rendered intensely hard by cold water spray. Nickel-chrome steel is the material *par excellence* for armour-piercing projectiles, which contain carbon 0.55 per cent., chromium 0.65 per cent., and nickel 2.60 per cent. Chrome-nickel steel is extensively used for motor-car crankshafts, axles, and gears, requiring great strength and toughness.

Mechanical Properties of Nickel and Nickel-Chrome Steels.

Alloy Steel.	Condition.	Tensile Strength. Tons per sq. in.		Elongation per cent. on 2 ins	Con- traction of area per cent.
		Elastic Limit.	Ulti- mate		
3 % Nickel Steel	As rolled ...	29.0	44.0	32	54
	Oil-tempered	80.0	83.5	16	42
5 % " "	Normal ...	25.5	38.0	33	60
25 % " "	Normal ...	25.0	47.0	46	66
Chrome-Nickel— (Tough) ...	Not hardening	42.0	51.0	26	65
(Case-hardening)	Annealed ...	32.0	51.0	24	55
	Case-hardened	70.0	83.0	13	50
(Air-hardening)	Annealed ...	40.0	60.0	24	55
	Air-hardened	95.0	115.0	13	40
(Oil-hardening)	Annealed ...	37.0	54.0	23	55
	Oil-hardened	92.0	105.0	9	25
	Tempered blue	82.0	95.0	11	45

Chrome-vanadium Steel has been shown to possess great strength, together with the power of resisting sudden shocks and the effects of rapidly alternating and repeated stresses in a very high degree. Being as easy to forge and machine as carbon steel, it has been much used for crankshafts, live axles, gear wheels, etc., for motor-car work. Chrome-vanadium steel has proved particularly suitable for springs, having a limit of elasticity double that of ordinary carbon steel. For this purpose the composition would be: Carbon, 0.50 per cent.; chromium, 1.0 to 1.25 per cent.; vanadium, 0.18 per cent.; manganese, 0.8 to

1.0 per cent. Crankshaft steel, to be oil-tempered, is composed of 0.25 per cent. carbon, 1.0 per cent. chromium, and 0.18 per cent. vanadium. Its elastic limit is 50 tons per square inch, and ultimate strength 62 tons per square inch, the elongation being 22 per cent. on 2 inches, and contraction of area 56 per cent.

Manganese Steel, introduced by Hadfield, contains from 10 to 15 per cent. of manganese, and from 0.4 to 2 per cent. of carbon. It possesses great strength, reaching 60 to 70 tons per square inch; but the elastic limit is very low, usually about 30 per cent. of the ultimate strength. Its chief characteristic is its extreme hardness, on which account it cannot be machined, and it is difficult to forge or roll. It casts well, however, so that its use will probably be confined to articles which have to resist wear, such as tramway points and crossings, parts of crushing and grinding machinery, etc.

Tungsten Steel.—It has long been known that the effect of tungsten is to render steel "self-hardening," a property of which advantage is taken in the well-known "*Musket*" steel, which may be worked in the ordinary way at a red heat, and becomes hard when allowed to cool in air, without quenching in water. As made in Sheffield for many years past, this contains 9 per cent. of tungsten, with 1.85 per cent. carbon, and 1.5 per cent. manganese. It is still much prized as one of the best tool steels for machining with heavy cuts, and it is also largely used for making permanent magnets. It was whilst experimenting with this steel that Messrs. Taylor and White, of the Bethlehem Ironworks, U.S.A., discovered that by a special heat treatment a tool could be made to retain its strength and hardness by heating to a yellow heat before cooling. This enables the cutting speed to be increased to such an extent that the point of the tool becomes red-hot when at work, *i.e.*, the steel possesses the property of "red hardness." The "*Taylor-White*" high-speed steel is said to have the following composition:—

	Per Cent.
Carbon	0.68
Tungsten	18.00
Chromium	5.75
Manganese	0.09
Vanadium	0.30
Silicon	0.46



ne Relative Sta

A "QUALITY FIVE

		Dyntc Figs.
ug.	Red. of Area %	Alta- ti
(R)		
5	53.8	3
0	60.1	1
5	53.4	2
0	62.6	1
0	64.0	7
0	63.4	5
0	65.3	5
0	69.0	8
0	68.5	8
0	44.9	19
5	44.9	10
0	20.5	18

10	62	46
10	65	164
10	57	308
15	15	260
10	61	406
15	68	507
10	64	798
0	49	883
10	63	702

15	1561
10	1480
10	717
10	626
0	487
0	634
15	579

PRO
repr Useful
repr Static
repr Fatigue
0 x R x
lion 10s

The heat treatment employed consists in raising the steel to a temperature of 2800° F., and then cooling in a blast of cold air (see page 124).

It should be understood that the very remarkable properties of the various alloy steels can only be secured by proper *heat-treatment*. This demands great skill and experience, and constitutes one of the most striking applications of metallurgical science.

Some useful information on alloy steels is contained in the following tables, which have been furnished by the American Vanadium Company, of Pittsburg, U.S.A.:—

- (1) Results of comparative tests on different varieties of iron and steel to determine relative strength and resistance to fatigue.
- (2) Composition of chrome vanadium steels.
- (3) Mechanical tests of typical alloy steels.

Table 2.—Types of Vanadium Steel.

A ₁	A ₂	A ₃	B	C	D ₁	D ₂	E
COMPOSITION.							
Per cent. Carbon, 0.25 to 0.30 Manganese, 0.40 to 0.50 Chromium 1.0 Vanadium, 0.16 to 0.18	Per cent. Carbon . 0.25 Manganese, 0.40 to 0.50 Chromium 1.0 Vanadium, 0.16 to 0.18	Per cent. Carbon . 0.25 Manganese, 0.40 to 0.45 Chromium 1.0 Vanadium, 0.16 to 0.18	Per cent. Carbon . 0.20 Manganese, 0.30 to 0.40 Chromium 0.50 Vanadium, 0.12	Per cent. Carbon . 0.20 Manganese 0.40 Chromium 0.80 Vanadium 0.16	Per cent. Carbon . 0.45 Manganese 0.80 Chromium 1.25 Vanadium 0.18	Per cent. Carbon . 0.45 Manganese 0.80 Chromium 1.25 Vanadium 0.18	Per cent. Carbon, 0.12 to 0.15 Manganese 0.20 Chromium 0.30 Vanadium 0.12
APPLICATIONS.							
Connecting Rods, Piston Rods, Coupling Rods and Steam engine parts in general (moving).	Crank Shafts, Transmission Shafts, etc.	Gears in contact mesh (not unduly pressed).	Axle work, Hammer Rods, and where torsion is of great moment, Bolt Steel.	Intermediate Steel very useful. Car axles, Holding bolts, etc.	Solid wheels, Gun barrels, etc.	Automobile and Carriage Springs.	Case-hardening steel.
HEAT TREATMENTS.							
Anneal @ 800° C., one or two hours, cool in air or ashes according to nature of piece.	Quench from 900° C. in lard or fish oil and anneal @ 550° C. for 2 hours according to size; cool in air.	Quench from 950° C. in lard oil and let down @ 360° C. for 1 hour, preferably in lead bath; cool in air.	Normal.	Normal.	Anneal @ 800° C. for 1 hour, cool fairly slowly, taking great care not to chill, or to pass from 800° C. to 600° C. too quickly.	Quench in oil from 870° C. and draw back @ 400° C. to 450° C. in lead bath pre-ferred; cool in air.	Regular case-hardening process.

All Steels to be as pure as possible from Sulphur and Phosphorus. Sulphur may go to 0.085 per cent. without detriment. With Phosphorus @ 0.01 per cent., the silicon may be 0.15 per cent. in "D" and 0.10 per cent. in "A," "B," and "C." With Phosphorus @ 0.03 per cent., the silicon should not exceed 0.05 to 0.06 per cent. in any case.

Table 3.
Results of Mechanical Tests of Typical Vanadium and other Steels, suitable for Automobile Purposes.

Test.	Carbon axle Steel.	Nickel axle Steel.	Vanadium axle Steel, Type A, No. 1.	Vanadium Crankshaft Steel, Type A, No. 2.	Vanadium Gear Steel, Continual Mesh, Type A, No. 3.	Nature of Test.
Yield point, tons per sq. in.	18.45	21.99	23.38	49.15	100.00	Static
Ultimate stress, tensile strength in tons per sq. in.	29.39	39.00	42.89	57.05	103.89	
Ratio	62%	56%	66%	87%	96%	
Elongation on 2 inches	42%	34%	33%	20%	11%	
Contraction of area	61%	58%	61%	58%	39%	
Torsional twists	2.6	3.2	4.2	2.5	1.8	Intermediate.
Alternating bends	10	12	18	10	6	
Pendulum impact, foot-lbs.	12.3	14	16.5	12	6	Dynamic
Alternating impact, number of stresses	960	800	2,700	1,850	800	
Falling weight on notched bar, number of blows	25	35	69	76	—	
Rotary vibrations, number of revolutions	6,200	10,000	67,500	—	—	

All figures were obtained under comparative conditions.

CHAPTER XII.

THE HEAT TREATMENT OF STEEL.

In practice, carbon steel is conveniently classified into mild steel, strong steel, and tool steel. Mild steel containing not more than 0.25 per cent. carbon is not appreciably hardened if heated to bright redness and suddenly cooled by quenching in water. On the other hand, tool steel containing 0.7 per cent. or more of carbon would be rendered very hard and brittle by this treatment. The degree of hardness produced increases with the percentage of carbon in the steel, and with the rapidity of cooling. It is also essential that quenching should be done at the correct temperature which varies with the grade and quality of the steel.

There is for each grade or temper of steel a temperature limit above which it must not be heated in the hardening process. Information on this point should always be supplied by the steel maker, but average values are given in the following table:—

Classification of Steel according to Carbon Content.

"Temper" or Degree of Hardness.	Examples of Use.	Carbon Content per cent.	Tem- perature Limit, F.°
—	Mild Steel for Boiler Plates . . .	0.20	—
—	Structural Steel	0.25	—
—	Rails	0.45	—
Die Temper .	Springs, sledge hammers, stamping dies.	0.70	1440
Sett Temper .	Miner's drills, &c., stonemason's tools, smith's tools.	0.90	1400
Chisel Temper	Hammers, chisels, woodworking tools, saws.	1.00	1380
Drill Temper .	Cutlery, knives, scissors, drills, axes, picks, punches.	1.10	1360
Turning Tool Temper	Lathe and planer tools, files, taps, reamers.	1.20	1340
Razor Temper	Razors, surgical instruments .	1.30	1320

It is now known that a difference in temperature of 10° F. is sufficient to account for the difference between good and bad hardening. It follows that the method of estimating temperature by reference to colour—as in speaking of white heat, yellow heat, bright red heat, etc.—cannot be sufficiently accurate, and the use of gas heated furnaces, the temperature of which is controlled by pyrometers, has now become general.

Hardening and Tempering of Steel.—Advantage is taken of the property just described in the production of edge and cutting tools of all kinds, and efficient hardening is therefore a matter of great practical importance. Suppose a piece of tool steel is heated in a furnace, the temperature rising at a uniform rate of (say) 20° per minute. On reaching a temperature of about 1340° F., a short period will elapse during which the steel does not become any hotter, although the temperature of the furnace continues to rise as before. After passing this critical point, known as W or Ac_1 , the temperature of the steel will follow the same uniform rate of increase as before, and may be allowed to reach (say) 1400° F. The furnace may now be shut off and, with the steel, allowed to cool down uniformly at the same rate as when heated, viz., 20° per minute. When the temperature has fallen to about 1280° F., cooling of the steel will be temporarily “arrested” for a short space of time, or it may be that it actually becomes slightly hotter, in spite of the fact that cooling down of the furnace proceeds at the same rate as before. After passing this point, known as V or Ar_1 , the steel continues to cool at a uniform rate. This remarkable property is known as *recalescence*, and it has an important bearing on the hardening of steel. The critical heating temperature Ac_1 , must just be reached or the steel will not be fully hardened on quenching. Hardening may also be effected at any temperature during cooling before reaching the point Ar_1 . The best practice would seem to be to heat the steel about 30° F. above the point Ac_1 , allow it to cool uniformly to within 30° of the point Ar_1 , and then quench “on the falling heat,” as it is termed. The correct hardening temperature for any steel may be ascertained from the appearance of the fracture by quenching specimens at different temperatures. An extremely fine grain is obtained when the exact temperature has been reached, the grain becoming coarser as the temperature at quenching is raised. Quenching is best performed in some liquid,

usually water or oil. Water, having the greatest capacity for heat of all known substances, produces the greatest hardness. Oil hardening is resorted to where toughness is more important than hardness, as in the case of springs, saws, etc. Steel quenched in water from the proper temperature is glass hard, and is said to be "hardened right out." In this condition it is much too brittle for any practical purpose such as the point of a cutting tool, and it becomes necessary to sacrifice some of the hardness in order to obtain strength and durability. The process of "tempering" is therefore resorted to, the degree of hardness being "let down" to suit the intended purpose. On heating a piece of hardened steel which has previously been polished, a series of colours, due to the thin film of oxide which forms upon the surface, will appear in a certain definite order. The colour produced is a rough indication of the temperature to which the hardened steel has been re-heated. If only slightly warmed, it will be found on again quenching that the steel has lost very little of its hardness, but the higher the temperature to which it is raised the less the hardness remaining after sudden cooling. Each colour roughly denotes the temperature corresponding to a certain degree of hardness, which in practice may be found suitable for some particular purpose, as shown in the following table:—

Table of Colours and Temperatures for Tempering Steel.

Colour.	Temperature. F. ^o	Purpose.
Faint Yellow	430	Surgical instruments, razors.
Pale Straw .	440	Turning and planing tools, milling cutters, hammer faces, paper knives.
Dark Straw .	480	Chasers, taps, screwing dies, shear blades, rock drills, reamers.
Red Brown .	510	Punches, reamers, stonemason's tools, axes, plane irons, twist drills, pen-knives, scissors.
Purple . .	540	Chipping chisels, smith's tools, table knives, cold chisels, hack-saws.
Blue . . .	560	Swords, springs, saws for wood.

High-speed Steel.—It will be seen that carbon steel loses its hardness at about 560° F. When cutting metal in a lathe or planing machine, the heat developed by friction at the tool point is considerable, and as the temperature must be kept down to avoid "drawing the temper," the speed of cutting is limited. This led to the introduction of high-speed tool steel which depends for its properties, not entirely on the amount of carbon contained, but mainly on the presence of certain other elements, of which the most important are tungsten and chromium. Such steels are not hardened in water but in a strong blast of air from a fan. They are forged at a bright red heat (1600° F.) and for hardening are heated slowly up to bright red and then quickly to a white heat (2800° F.) or until the steel appears to be on the point of melting or running. The critical temperature to which high-speed steel may be subjected when the tool is at work is about 1200° F., and the higher the hardening temperature above this critical point, the higher the temperature which the steel will endure when cutting. At the high temperature thus possible and with speeds of 100 to 150 feet per minute, the cutting removed by a turning tool from a steel shaft smokes and becomes blue. Under such conditions the point of the tool is dull red hot, and the heat generated is sufficient to draw the temper of the shaving to a dark blue. The special characteristic of high-speed steel is the property of "red hardness," or the ability to resist the softening effect due to the heat generated in cutting. If cooled from about 1750° F. high-speed steel is probably as hard as it can be made in a cold state. But it does not possess the property of red hardness, and is probably little superior in endurance to carbon steel. Its qualities can only be fully developed by heat treatment at a high temperature. By reheating to 2800° F. the cutting properties are increased to at least four times those of the same steel treated at 1750° F.

The **Hardening of Carbon Steel** comprises three distinct operations:—(1) Heating to the recalescence point (say 1800° to 1400° F.) to bring the carbon into the dissolved or hardening form; (2) sudden cooling by quenching, to fix the dissolved carbon; and (3) reheating, or tempering, to give the required degree of hardness combined with toughness. In heating, it is essential to maintain a uniform and exact temperature, for which a *gas-fired furnace* is eminently suitable, and the use of a pyrometer is

indispensable. It is most important that irregularly shaped articles should be heated uniformly throughout, which is best attained in the method of heating by immersion in a liquid, the temperature of which can be regulated and recorded with the greatest ease. The use of molten lead for this purpose is well known, and more recently a *bath of fusible salts* has been employed with great success. For carbon steel the "melt" consists of a mixture of common salt, soda, and borax, which becomes liquid at a temperature of 1470° F. and which is contained in a steel pot or crucible placed in the centre of the furnace. The articles to be heated are placed on a tray capable of being lowered into, or raised from the bath as required. By means of a thermo-couple pyrometer inserted through the cover of the furnace the temperature may be read off to 2° F. For quenching, the tanks or "boshes" are best made with an outer casing or jacket, through which cold water may be caused to circulate, to keep the liquid itself at a constant temperature.

Tempering is best performed by immersing the hardened articles for a given length of time in a bath maintained at a definite temperature as required (see table, p. 122), a thermometer graduated to 600° F. being permanently fixed in such a position that the readings may be readily taken. Oil of high flash point (say 570° F.) is probably best for temperatures up to 480° F. corresponding to dark straw. Beyond that, a bath of fusible salts, or an alloy of lead and tin may be used. After remaining in the bath for a sufficient length of time to acquire the temperature of the liquid, the articles are withdrawn, usually in a wire basket or strainer, to receive the final quenching.

Springs are tempered by the process known as "blazing off." After dipping in oil of suitable flash-point, they are heated until the oil burns with a white flame, when they are quenched.

The **Hardening of High-speed Steel** is effected in two stages:—(1) heating slowly to bright red, and then rapidly up to about 2300° F.; (2) cooling off in a blast of cold air, or with some varieties of steel, quenching either in a bath of oil or paraffin maintained at the proper temperature, or in a "low temperature melt" of fusible salts. For heating on account of the high temperature, it is necessary to use a blast, or "high pressure," gas furnace, worked with either air or gas under pressure. The most convenient plan is to employ gas at ordinary pressure, and air,

supplied by a positive blower, at a pressure of 1 or 2 lbs. per sq. inch. The heating, being performed in two stages, is best carried out in a furnace of the "twin-chamber" type, as made by Mr. S. N. Brayshaw, of Manchester, in which the heat from the lower chamber passes through the upper one on its way to the flue. The upper chamber is used to pre-heat the steel to a temperature of about 1600° F. when it is rapidly transferred to the bottom chamber, in which the hardening temperature of 2300° F. is reached as quickly as possible. This is done to avoid scaling and decarbonisation, which would occur by too long exposure at so high a temperature. For the same reason, when hardening high-speed steel it is desirable to work with a reducing atmosphere.

A form of furnace possessing many advantages is one in which a bath of barium chloride, which melts at 1740° F., is maintained in a molten condition by means of an electric current flowing between cast iron electrodes immersed in the salt. The atmosphere is entirely excluded from the objects to be heated, and the temperature is easily adjusted by simply regulating the current.

For quenching, an open bath is used, consisting of a steel pot in a fire-brick lined furnace, heated by a high-power Bunsen burner. A low temperature "melt" of fusible salts such as nitrates of potash and soda in equal parts has the advantage that it may be kept at the correct temperature, just above the fusing point, without the use of a pyrometer. It is claimed that steel treated in this way is harder and more uniform in texture than if cooled in an air blast, and the open bath is more economical, both in first cost and working, than a fan or air compressor.

Theory of Heat Treatment.—Strictly speaking the hardening and tempering of tool steel is to be regarded as one form of heat treatment, and in dealing with that part of the subject, it has been shown that the condition of maximum strength in steel is identical with fineness of grain, coarse structure, on the other hand, being synonymous with weakness. It may be said that the main object of heat treatment is to reduce the grain of the material to the greatest possible degree of fineness. Steel has been described as a "solid solution" of carbon in iron, and it may be assumed that iron dissolves carbon just as water dissolves salt. At a high temperature the carbon is in solution in what is known as the hardening form, but on cooling down to the recalescence point it can no longer

exist in this condition, and it separates out of solution, being thrown down as a definite carbide, Fe_3C , known as cementite. The celebrated Swedish metallurgist, Brinell, has shown that the temperature W , at which the carbon passes from the carbide to the solution or hardening form, coincides with the development of maximum fineness of grain. The lower limit, V , at which the carbon changes from the hardening to the cementite form, is separated from W by a range of 40° or 50° F. These limits, W and V , coincide with the recalescence points Ac_1 and Ar_1 on the heating and cooling curves respectively. By heating to W , followed by slow cooling, fineness of grain is retained. Heated to W , and cooled suddenly also preserves the fineness of grain, but the steel is fully hardened. It will also be fully hardened if first heated above W , then allowed to cool down to W , and there quenched; but the grain will be coarser than would be obtained by heating to W and quenching from that temperature.

Above W the grain becomes coarser the higher the temperature from which cooling takes place, and the slower the rate of cooling the larger are the grains. At about 2000° F. carbon steel is "burnt," the structure then consisting of large crystals partly separated from each other by a film of oxide. From this state the original condition cannot be restored by any form of heat treatment other than re-melting.

Annealing.—The simplest form of heat treatment is annealing, the object of which is to relieve internal stresses induced by the operations of casting, forging, rolling, stamping, wire drawing, etc. It is well known that the mechanical working of metals, especially in the cold state, renders the material harder and stiffer and may even induce brittleness. Bright steel bar for use in turret lathes and automatic machinery undergoes a process of drawing to bring it exactly to size and may have its ultimate tensile strength increased from 26 to 35 tons per sq. inch, elongation being at the same time reduced from 26 to 16 per cent. in 8 inches. The original condition can be restored by annealing and the material is then said to be *normalised*. In this case, however, annealing would destroy the bright surface of the bar, and the metal must therefore be left in its untreated condition. The object of annealing is, in general, to lower the ultimate strength of the material and to increase the elongation and contraction of area, thus producing softness and ductility and the

ability to offer the maximum resistance to impact and sudden shock.

Annealing consists in heating the material up to a certain definite temperature, which is maintained for a sufficient length of time to liberate any internal stresses, and is generally followed by slow cooling to retain the finely crystalline structure. Brinell has shown that the proper temperature for annealing steel is a low yellow heat slightly above W, *i.e.*, the recalescence point Ac_1 on the heating curve, about 1350° F., and that the effects of mechanical work may be removed by heating through the range V to W. Slow cooling is effected by covering with a layer of ashes or other non-conducting material, or in some cases, simply in the open air. Steel castings are invariably annealed, usually in a gas-fired furnace of the reverberatory type, which, after the requisite heating, is carefully luted up to ensure as slow cooling as possible. Silver, copper, and certain bronze alloys are rendered softer and more malleable by rapid cooling. Copper is annealed by heating to 1340° F. followed by sudden quenching in water, but it is found that brass used in the manufacture of cartridge cases may be cooled either suddenly or slowly without affecting the quality of annealing, the most suitable temperature being 1200° F.

Carbonising or Case Hardening is a form of heat treatment designed to produce a hard wearing surface on a tough interior. The process is applicable to wrought iron, mild steel and certain of the alloy steels and is in principle the same as the cementation process for the manufacture of crucible cast-steel described at p. 61. The articles to be treated are placed in a cast-steel box and packed round with carbonising mixture. The cover is then luted on, and the box raised to a bright cherry red heat, say 1750° F., preferably in a gas-fired oven or furnace, in which a reducing atmosphere is maintained, the temperature being regulated by means of a pyrometer. The temperature is kept up for some time, depending on the depth of "case" required, and the carbonising medium used. The box and its contents are allowed to cool down before opening, and after cleaning, the articles are ready for the second operation of re-heating and quenching. The surface to the depth of $\frac{1}{8}$ inch or more has been converted into high-carbon steel, which is hardened by this latter treatment. The core in the interior is required to remain tough and fibrous, and

it is desirable to bring out fully the fine-grained structure by a second heating to the proper temperature, say 1600° F., followed by quenching in cold water.

Messrs. Vickers Ltd., of Sheffield, state that a much better result is obtained by first heating to 1650° F. and quenching in cold water, then re-heating to 1450° F. and again quenching in cold water. This gives a fine white glass-hard skin, with a very tough and fibrous backing.

The case-hardening mixture consists of certain substances rich in carbon, usually of organic origin, and containing also nitrogenous matter. The presence of nitrogen appears to be essential, carbon alone being very feeble in its action. Bone dust, horn, hoof and hide clippings, scraps of leather and similar substances are specially prepared by calcination and charring, and sometimes mixed with a quantity of vegetable oil. Certain chemicals, such as barium carbonate and yellow prussiate of potash, are also occasionally added, and this latter substance alone when powdered and sprinkled upon a surface of wrought iron or mild steel which has been raised to a cherry red heat, is capable of producing a very thin casing.

To produce a case-hardened article having a hard skin with an interior core of tough ductile character capable of resisting fracture under shock, it is not essential, as commonly assumed, to use very soft steel of low tensile strength. Case-hardening nickel steel is now produced, giving an exceedingly hard skin with an interior core of high tensile strength, but at the same time, an entire absence of brittleness. Messrs. Vickers Ltd., who are well known as makers of this and other types of special steel, state that to obtain a thickness of skin of $\frac{1}{32}$ inch, suitable for gear wheels, etc., the articles should be heated to 1750° F. in any commonly used casing mixture. At the end of 2 or 3 hours the box containing the articles should be allowed to cool slowly. When cold, they should be removed and heated in a gas muffle furnace for hardening. With case-hardening nickel steel, two entirely different results may be obtained by hardening in cold or in boiling water. Quenching in the latter gives a rather softer skin, and a much softer core. For hardening in cold water, the temperature should be raised to 1400° F., the steel removed from the furnace, allowed to cool a few degrees in the air, and then quenched. To harden in boiling water, the article is heated to 1450° F., and at

once plunged into actually boiling water. The results obtained are shown in the following table :—

Tensile Tests of Vickers' Case Hardening Nickel Steel.

Condition.	Elastic Limit. Tons per sq. in.	Ultimate Strength. Tons per sq. in.	Elongation. Per cent. on 2 ins.	Reduction of Area. Per cent.
Softened for machining	28·0	33·0	33·0	65·0
Quenched in boiling water from 1450° F.	30·0	36·5	32·0	70·0
Quenched in cold water from 1450° F.	61·6	67·6	16·0	57·0

The special alloy steels so much used in motor car construction, where it is desired to bring out great strength and toughness, together with fatigue and shock-resisting properties, are subjected to a form of heat treatment which must be carried out with great care and extreme accuracy. For instance, chrome-vanadium steel for crankshafts is first heated to 1560° F. for $\frac{3}{4}$ hour, and is quenched in oil. It then undergoes a process of annealing for about 8 hours in a bath of molten lead, and is finally allowed to cool down in lime.

CHAPTER XIII.

NON-FERROUS METALS.

COPPER.

OF all the metals used in engineering work, copper stands next in importance to iron. Copper is the only red metal, and when pure it is remarkable for its extreme toughness, malleability, and ductility. On this account it has been largely used for steam and water pipes, hemispherical stills, vats, pans, etc. "Solid drawn" copper pipes are produced up to about 6 inches in diameter, larger sizes being made from sheet, bent or hammered to the required form, and brazed at the joints. Copper is an excellent conductor of heat and electricity, being in this respect second only to silver. For this reason copper in the form of wire is used to an enormous extent in electrical engineering. It remains unaltered on exposure to air free from carbon dioxide and other acid vapours; but when these are present a coating of basic salts of a beautiful green colour is formed upon the surface, rendering the metal almost indestructible. Sheet copper as a roofing material takes high rank, as it may be easily adapted to any shape, and is very light. Copper can be forged at a red heat, but will not weld. It melts at 1900° F., but copper castings are very liable to be blown and to contain cavities due to the presence of oxide. Copper rapidly loses strength at moderate temperatures, and is not suitable for use with high-pressure steam. Nevertheless, by reason of its high thermal conductivity and ability to resist corrosion, it is in great demand in this country for the fireboxes of locomotive engines. It is in the production of a large number of useful alloys, which will be considered later, that copper finds its most important industrial application.

Occurrence and Reduction of Copper Ores.—Large masses of native copper are found in the Lake Superior district, and in the form of grains distributed throughout the rock it occurs in Chili and in Cornwall. The most important ore is copper pyrites,

which has the composition $\text{Cu}_2\text{S}, \text{Fe}_2\text{S}_3 = \text{CuFeS}_2$, and is found in great abundance in Cornwall, Sweden, Germany, and the United States. Extensive deposits of red and black oxides also occur in Cornwall, Australia, and elsewhere. The ore raised in Cornwall is sent to South Wales to be smelted, the method of reduction being in consequence known as the Welsh process.

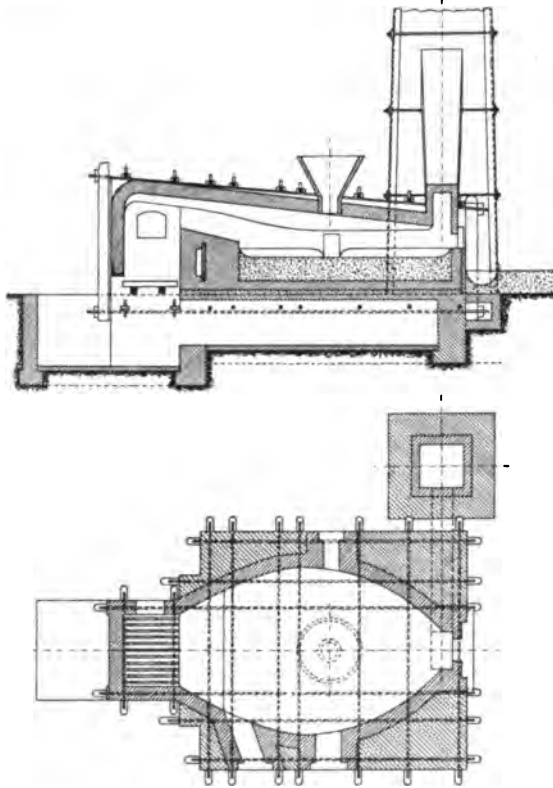

FIG. 71.—Copper Smelting Furnace.

It comprises six distinct operations, all of which are carried out in reverberatory furnaces of the type shown in Fig. 71. The ore, which contains 10 or 12 per cent. of copper in the form of sulphide, is first calcined at a low temperature, the charge being introduced through hoppers in the roof of the furnace. A large quantity of sulphur is driven off, and the roasted ore is raked out into a chamber below the furnace and allowed to cool.

The chemical reaction which occurs may be represented as follows:—



At the same time, the bisulphide or iron pyrites, FeS_2 , present in the ore, is reduced to ferrous sulphide, thus:—



In the second operation, the roasted ore is fused with a quantity of slag from the fourth stage, fluorspar being added as a flux, if necessary. The oxide of copper reacts upon the sulphide of iron, forming sulphide of copper and oxide of iron, which latter, together with that produced during roasting, combines with the flux to form slag, thus:—

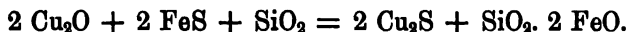

The “regulus,” consisting of sulphide of copper and sulphide of iron from the ore, collects at the bottom, with the slag floating above. This *ore furnace slag*, as it is termed, is skimmed off by means of a rabble and drawn out into a bed of sand. The regulus is then run out into a trough of water below the furnace for granulation, or into a bed of damp sand, when it is known as “coarse metal.” In the third operation, the coarse metal is broken up and roasted with slag from the fifth process in the calcining furnace, with repeated puddling of the charge. In the fourth operation the roasted coarse metal is fused with slag and oxidised ores in the “metal furnace,” the same reaction between the sulphides and oxides taking place as in the first operation. The object at this stage is to get rid of the iron, leaving a rich “matte” which is mainly copper disulphide, known in smelting works as “white metal.” The *metal furnace slag* formed at the same time may contain 5 or 6 per cent. of copper which, as already described, is recovered in the second operation. In the fifth stage, fine metal in the form of pigs from the previous operation is roasted by exposing it when molten to the action of a strongly oxidising atmosphere in the calcining furnace, thus:—

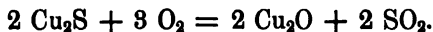

The slag is repeatedly skimmed off, and a violent ebullition takes place, sulphur dioxide being liberated by the action of the oxide on the sulphide:—

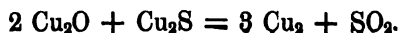

The metallic copper so formed is run off into sand moulds, and cast into pigs. After solidification, the resulting metal is found to be full of blowholes and to have a blistered appearance due to the escape of sulphur dioxide, whence it is known as "blister copper." The sixth and final stage is that of refining and toughening. A charge of blister copper is melted on the bed of the refining furnace, skimmed, and worked as clean as possible by exposure to an oxidising flame for several hours. The object is to remove the more readily oxidisable impurities in the form of oxides, especially bismuth, antimony, tin, lead, and arsenic. These are accompanied by a certain amount of copper which has been oxidised to cuprous oxide, and together go to form a slag with the silica from the sand bottom of the furnace. Unfortunately some of the cuprous oxide is at once dissolved in the molten copper, and to effect its removal, the process known as "poling" is resorted to. After removal of the slag, the surface is covered with powdered charcoal, and the metal stirred vigorously by means of a birch pole. This sets up a violent ebullition due to the escape of steam and gases, thus bringing the cuprous oxide into intimate contact with carbonaceous matter, and reducing it to metallic copper with the disengagement of carbonic oxide. A test of the metal is repeatedly taken in a small iron ladle, and when it forges "soft," and may be hammered out flat without cracking at the edges, it is said to have reached "tough pitch." It is then ladled out of the furnace into cast iron moulds in the form of either ingots or slabs, which, when solid, are dropped into water.

At Mansfeldt in Prussia, in Tasmania, and also in America, oxides and carbonates of copper are smelted in water-jacketted blast furnaces, with coke as fuel, and a suitable flux, such as oxide of iron to form slag with the silica.

Blast Furnaces for Copper Smelting for the production of "matte" from pyritic ores, or of "black copper" from carbonates and oxides, may be made of circular form for treating small quantities not exceeding 30 tons of ore in twenty-four hours. It has, however, been shown by experience that 24 inches is about the limit of penetration of the blast under normal conditions, and consequently circular furnaces should not be made more than 48 inches in diameter. For dealing with large quantities, the rectangular furnace has been adopted, of which an example,

made by Messrs. Thwaites Bros., Ltd., of Bradford, is shown in Fig. 72. This furnace, which has a smelting capacity of 125 tons

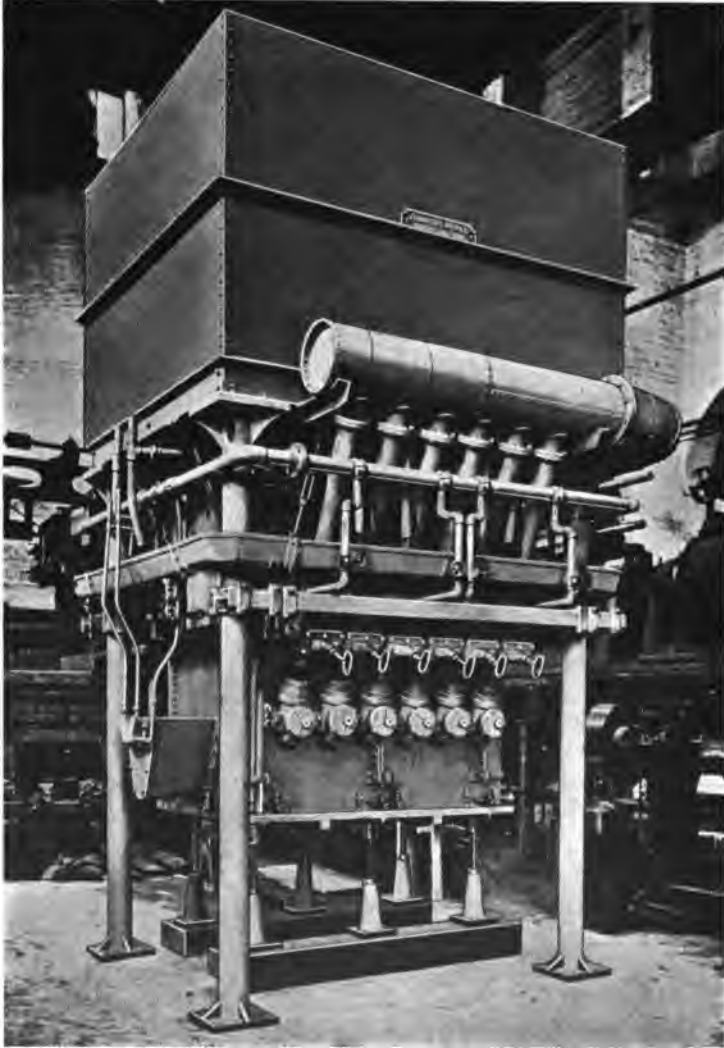

FIG. 72.—Rectangular Blast Furnace for Copper Smelting.

of pyritic ore per twenty-four hours, is fitted with a water-jacket of steel plates, the upper portion, supported on a mantle frame

resting on pillars, being lined with brickwork and surmounted by a conical hood terminated by a steel chimney stack to carry away the products of combustion. The main blast or "bustle" pipe is independently connected with each of the 12 tuyeres, which are arranged 6 on each side of the furnace, and each tuyere is provided with its own regulating valve, so that any one can be closed without interfering with the others. The charging doors of plate iron are counterbalanced, and are placed on each long side of the furnace. The furnace is provided with a cast iron bottom or "crucible" mounted on screw jacks, and for easy removal it may be lowered on to a wheeled truck, Fig. 73,

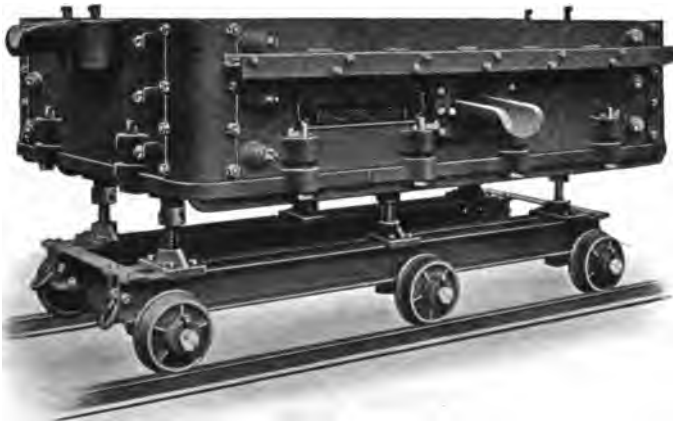

FIG. 73.—Bottom for Copper Smelting Furnace.

and rolled out of position when a new bottom is to be substituted. The crucible is fitted with slag and matte spouts, which are sometimes water-jacketted. As the specific gravities of the matte and slag do not differ greatly, some time must be allowed for their separation. This may be effected either inside or outside the furnace. For smelting black copper or rich mattes the crucible is made deeper to allow the slag to collect, the matte and slag being tapped direct from the furnace through two tap holes at different levels. Mattes containing a low percentage of copper have a highly corrosive action on the bottom, and it is therefore preferable to provide a "forehearth" where the separation of the matte and slag can take place outside the

furnace. In this case, the crucible is made shallow and is provided with a water jacket, the products of smelting passing away by a syphon spout to the forehearth, which is thickly lined with firebrick or magnesite, and mounted on wheels for ready removal. The blast, at a pressure of about 1 lb. per square inch, is supplied either by a fan or a Roots' blower.

The **Wet or Leaching Process** is used at Rio Tinto in Spain for ores in which the copper is present as carbonate or oxychloride, in a gangue of siliceous material. The ore is broken to pieces and is placed in the leaching vats, which are usually of wood lined with lead, and measure about 12 feet square and 4 feet deep. Dilute sulphuric acid is then run in, and is kept in circulation until solution is complete, heating by steam being resorted to if necessary. The chemical action is as follows:—



Copper may also be converted into sulphate by calcining ores containing pyrites at a low temperature:—

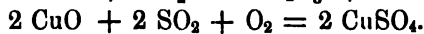
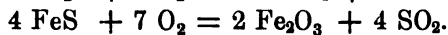
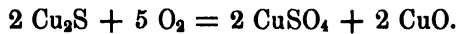

The solution of copper sulphate is conducted to precipitating vats, where the copper is thrown down by means of scrap iron. After emptying the vat, the finely divided copper is washed into a settling tank, where it is drained and dried. The "copper precipitate" is then sent to the smelter, to be fused and refined.

Impurities in Copper.—The chief varieties of commercial copper are known as (1) "*Best selected*" copper, prepared from the purest materials, and specified to contain traces only of arsenic and antimony, bismuth being absent; (2) *Tough Cake*, the ordinary copper of commerce, containing as much as 0·8 per cent. of arsenic and a quantity of other impurities; (3) *Chili bars* as imported in ingots weighing 2 cwts. each, which require refining, often containing as much as 1 per cent. of sulphur and 2 per cent. of other impurities; (4) *Electrolytic copper*, which is very pure. The impurities present in ordinary copper are arsenic, antimony, bismuth, lead, nickel, tin, and oxygen in the form of cuprous oxide. For most purposes, impurities, if present in small quantities, appear to have a beneficial effect rather than

otherwise. Thus, arsenic hardens copper, and increases its tensile strength, and for locomotive firebox plates and boiler tubes it may reach from 0·2 to 0·3 per cent. with advantage. Bismuth, on the other hand, is an exceedingly deleterious constituent, about 0·05 per cent., making the copper so brittle that it becomes quite unworkable either hot or cold. Antimony has a very similar effect to arsenic, but the best quality copper never contains more than a trace. Cuprous oxide, if dissolved in large quantity, produces excessive brittleness. It is found, however, that if in the poling process the last traces of oxygen be removed, the metal loses its toughness and becomes dry and brittle. It is then said to be "over poled." For electrical purposes, it is especially necessary that copper should be pure, as an exceedingly small proportion of impurities will cause a remarkable falling off in conductivity. Electro-refining was at one time largely adopted, a successful process being that of Elmore, as used at the Yorkshire Copper Works, Leeds. The copper was deposited in the form of tubes, which were made up to 4 feet in diameter and 18 feet long. For this purpose, mandrels of the same diameter as the inside of the tubes to be produced were connected to the + pole of a dynamo and made to revolve constantly in tanks containing a solution of 15 per cent. copper sulphate and 5 per cent. sulphuric acid, anodes of pure copper being arranged alongside them. Agate burnishers, held in wood supports and fitted to a frame placed transversely over the tank, were caused to travel automatically up and down the whole length of the tube during the time the operation of depositing was in progress. This burnishing was intended to give the tubes a more uniform density, leaving a perfectly smooth surface, and was claimed to be the cause of the high tensile strength which the deposited copper possessed. Before being placed in the vats the mandrels were covered with black lead to facilitate removal of the finished tube. Not the least profitable feature of this method of refining is the value of the sediment or "slime" which remains in the cisterns, and which has been found to contain as much as 250 ounces of gold to the ton of residue.

The electrolytic process has proved exceedingly valuable for the production of drying cylinders, calico-printing rolls, paper machinery, pump liners, hydraulic ram covers, etc. Experience on board ship has unfortunately shown that electro-deposited

pipes, carrying high pressures, are scarcely more reliable than brazed ones. The material is subject to a want of uniformity in structure, being amorphous in some places although quite fibrous in others, and tests have shown that the ductility in a circumferential direction is much less than longitudinally. On the other hand, although chemical purity is of great importance where electrical conductivity is the chief requirement, it is found that pure copper has comparatively little resistance to wear, and would suffer severely, for instance, under the erosive action of small particles of fuel and ash moving with considerable velocity under the action of a powerful blast in a locomotive boiler. The addition of a small proportion of arsenic, not exceeding 0.35 per cent., is sufficient to effect a very great increase in durability under such circumstances.

Copper to be made into plates is first cast into slabs, which are rolled out partly while still hot, the operation being completed subsequently by a certain amount of rolling when cold. The quality of the plate is greatly influenced by the amount of work put into the metal during the latter part of the process, and it may be said that unless subjected to mechanical work of some kind or other, copper in any form is of very little service. When hammered or worked cold, copper tends to become hard and brittle, losing its ductility to some extent. All plates, rods, tubes, etc., of copper must be therefore thoroughly annealed before use. This is usually effected by heating to a bright red, the pieces being kept at the annealing temperature for a few minutes, and then quenched in water. It would appear that very little difference is made by sudden quenching in water, or by allowing the metal to cool down slowly. During the process of drawing into wire, copper must be annealed to avoid fracture.

Copper should not be heated in a reducing atmosphere, such as coal gas, or carbon monoxide produced on the brazing hearth with a slow fire and an insufficient supply of air. Under such conditions, the metal may be "gassed," or "burnt," becoming so brittle that fracture occurs with the slightest bending. It is possible that the same deterioration may occur under similar conditions in actual use, and this action is in all probability the cause of most of the disastrous accidents which have occurred with brazed steam pipes, etc. Prolonged heating at a high temperature will

also produce brittleness, which has been shown by microscopic examination to be due to very coarse crystallisation.

The alloys of copper are of great importance, and are extensively used in engineering work.

TIN.

Tin is a white, highly lustrous metal. It melts at a much lower temperature, viz., 450° F., than any other common metal, and it is a poor conductor of heat and electricity. Its tensile strength is very low, reaching only about 2 tons per square inch, but it is very malleable, and may be beaten out into "foil" of a thousandth of an inch in thickness. On account of the high price of tin, however, the "tin-foil," or "silver paper," of commerce, so much used as a covering for chocolate, soap, tobacco, etc., generally contains a very large proportion of lead. Used alone, tin possesses the valuable property that air, whether moist or dry, has no action upon it at ordinary temperatures, neither is it affected by animal or vegetable acids. Hence, thin sheet steel coated with tin, and known commercially as *tin plate*, or *sheet tin*, is extensively used for canning articles of food, and for the manufacture of vessels for cooking and dairy purposes.

Tin is smelted almost entirely from tinstone (stannic oxide, SnO₂), which occurs largely in Cornwall, Straits Settlements (Banca), Australia, Mexico, etc. The ore is first roasted, arsenic and sulphur being driven off in the form of oxides, and any copper converted into sulphate. After moistening, the mass is allowed to remain for several days with the object of producing other soluble sulphates. These are dissolved out by thorough mixing with water in a large tank, stannic and ferric oxides being deposited. The latter, being lighter, is separated by further stirring and washing, *black tin* in the form of oxide remaining. The tin oxide is reduced by heating with about 20 per cent. of powdered anthracite in a reverberatory furnace, lime being added as a flux. The action is as follows:—

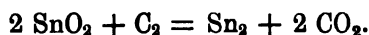

The metal is run out into moulds, and the pigs are subsequently subjected to a refining process, known as "liquation," by melting on the hearth of a reverberatory furnace.

Tinning.—A peculiar property of tin is utilised in the manu-

facture of *tin plate*. If a perfectly clean surface of wrought iron or mild steel be dipped into a bath of molten tin maintained at a temperature somewhat above the melting point, the tin will combine with the iron forming an alloy at the surface, on which a thin coating of tin is readily deposited. Brass and copper articles which have been thoroughly cleaned and heated slightly above the melting temperature of tin may be coated by first sprinkling the surface with powdered ammonium chloride before wiping over the molten metal with a piece of tow.

ZINC.

Zinc, known commercially as "spelter," is, next to iron, the cheapest of all metals. It is crystalline and brittle, but at about 220° F. it becomes malleable, and may be rolled into sheets, which are usually made about 6 or 8 feet long and 3 feet wide. In this form it is largely used for roofing purposes, being only slightly affected by atmospheric influences. At a higher temperature, about 400° F., it again becomes brittle, and may be granulated or powdered. It melts at 770° F., and being very fusible, may be readily cast into ornamental tiles, ridge crestings, etc.

Exposure to air causes a film of insoluble carbonate to form upon the surface, protecting the metal from further oxidation. As a protective coating for ironwork, zinc is to be preferred to tin. The process of covering iron with zinc is known as *galvanising*. The articles are first pickled in dilute acid, and, after washing, are dried, and then dipped in a bath of molten zinc, which is covered with a layer of sal-ammoniac to act as a flux. Corrugated iron for roofing, etc., is produced in this way. Cold galvanising, or electro-zincing, is also resorted to in special cases. Galvanised iron is rapidly attacked by sea air, or by the sulphurous vapours of large towns. Unlike tin, zinc is soon destroyed by both acids and alkalis, and cannot therefore be used for canning food, etc. Zinc white, or oxide of zinc, is now very largely used as a base for oil paint, and being non-poisonous, is much to be preferred to white lead for this purpose.

The chief ores of zinc are calamine, which is an earthy carbonate, $ZnCO_3$, and blende or black jack, which is the sulphide, ZnS . The former is found in Belgium and Silesia, and to some

extent in North Wales and Cumberland, whilst blende occurs in Russia, Silesia, North Wales, Derbyshire and Cornwall. The ores are first roasted to convert them into the oxide, which in the case of calamine is easily accomplished as follows:—

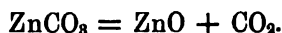

Blende is roasted at a higher temperature, and with an abundant supply of air

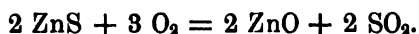

The extraction of the metal is effected by reducing the oxide with excess of carbon in closed fireclay retorts or muffles at a temperature about boiling point, the metal being vapourised and condensed in fireclay receivers. The action is as follows:—

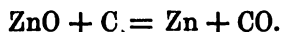

The metal is scraped out of the condensers in a molten state, and is found to contain several impurities, principally lead, sulphur, iron, cadmium, and arsenic. Purification is effected by fusion in a reverberatory furnace, when the lead separates and sinks to the bottom, and by subsequent re-distillation.

LEAD.

Lead is the softest of all metals used in the arts, and is also the heaviest of the baser metals. It melts at about 650° F. and volatilises at a white heat. As it contracts considerably on cooling, it is not adapted for casting in the unalloyed state. It is very malleable, and may be beaten out to any desired shape, but is wanting in tenacity, and is easily torn. On exposure to the air, it behaves much in the same way as copper and zinc, and in the form of sheet is a valuable roofing material. Sheet lead is made by casting a block 5 inches or 6 inches thick of about 5 tons weight, which is then rolled down to the required thickness in a rolling mill. The thickness of this "milled" lead is expressed as the weight in lbs. per square foot. It is obtainable in widths from 5 to 8 feet, and in length up to 10 or 12 yards. It is extensively used for flats, gutters, ridges, and flashings in roof work, and for lining vats and cisterns. The ability of lead to flow under pressure is very striking, and advantage is taken of this property in the covering of electric cables, and in the manufacture of lead pipes and rods, which are "squirted" in a semi-molten condition from a hydraulic press, in a manner

to be described later. Lead pipe being very easily bent and jointed, is universally employed for domestic purposes. Lead is readily attacked by soft or distilled water, from which lead poisoning may result, as all soluble compounds of lead are highly poisonous. With river or spring water, the small amount of sulphate present produces a deposit in the form of a very thin film of insoluble lead sulphate which protects the metal from further action. The thickness of lead pipe is usually designated in lbs. per yard, or in lbs. per "length." Up to 1 inch diameter, a length is 15 feet, from 1 to 2 inches diameter, it is 12 feet, and over 2 inches, 10 feet. Soil pipe is made from 2 to 6 inches diameter, and the thickness is specified as equal to so many lbs. sheet lead. Pipes of rectangular section are also manufactured.

Dilute acids have very little action upon lead, which in consequence plays an important part in many branches of chemical industry, as for example, in lining chambers for the manufacture of sulphuric acid. One of the chief uses of the metal is in the production of the plates for electric accumulators. White lead, (which is the basic carbonate of the metal,) although highly poisonous, is most extensively employed as a base for oil paint, and as a cementing substance for making pipe joints. Red lead, or minium, (Pb_3O_4) is also used in mixing paint, and for making watertight joints in metal work.

The most widely distributed ore of lead is galena, or lead sulphide, PbS , which occurs largely in North Wales, Derbyshire, Spain, and Germany. It is usually mixed with quartz, fluorspar, and barytes, and often contains silver, the ore being then described as argentiferous. During smelting, the silver is taken up by the lead, and if not less than 3 ounces to the ton be present, the rarer metal may be profitably extracted. The only other ore of lead of any importance is cerusite, or white lead ore, which is a carbonate, $PbCO_3$, found in Colorado, and at Broken-hill in Australia.

In Flintshire and Derbyshire, and in Spain, the *reaction process* of smelting galena is employed. By calcining the ore, the lead sulphide is partly converted into oxide and partly into sulphate, with evolution of sulphurous oxide, SO_2 , thus :—

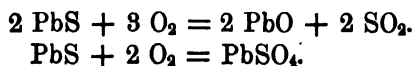

On further heating, the unaltered sulphide reacts upon the oxide and sulphate produced by roasting, the sulphur and oxygen combining to form SO_2 , leaving metallic lead thus:—

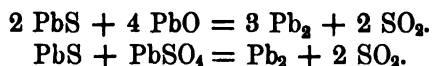

The operation is conducted in a reverberatory furnace, known as the Flintshire furnace. In America and in Germany, a *reduction process* is largely used, granulated iron, or iron slag, being added to the charge, which is smelted with coke or charcoal in a blast furnace. The action, which takes place at a full red heat, is as follows:—



White lead ore is first roasted, the carbon dioxide being driven off, leaving lead oxide—



The oxide so formed is then mixed with furnace slag or pyrites cinders, and a suitable fluxing material, such as lime, and is smelted in a blast furnace with coke as fuel. Reduction is partly effected by carbonic oxide, and partly by iron, the latter in the form of oxide combining with silica and passing into the slag, thus:—

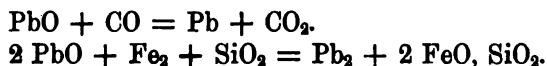

In the *ore hearth process*, used in the north of England, and in Scotland, the reaction and reduction methods of extraction are made use of simultaneously. Blast is supplied through a single tuyere at the back of the hearth, and oxidation is effected by the excess of air blown in, and by exposure of the charge on the "workplate." The oxide so formed reacts on the remaining sulphide as before, and is to some extent reduced directly by the carbon of the fuel.

ALUMINIUM.

Aluminium in the unalloyed state is too weak and soft for most practical purposes, having about the same strength as zinc, and in hardness, coming between tin and zinc. It is of a lustrous

white colour, does not oxidise or tarnish on exposure to the air, and is capable of taking a fine polish. It is, however, attacked by most acids and even to some extent by boiling water, and alkalies readily dissolve it. It melts about 1160° F., and its conductivity for heat and electricity is very high. Its most striking characteristic is extreme lightness, being nearly three times lighter than iron. As it occurs in nature even more extensively than iron, and does not suffer from corrosion, it was at one time regarded as a likely substitute for steel for constructive purposes. Although the price has been considerably reduced, and is now about the same as that of tin, these expectations have

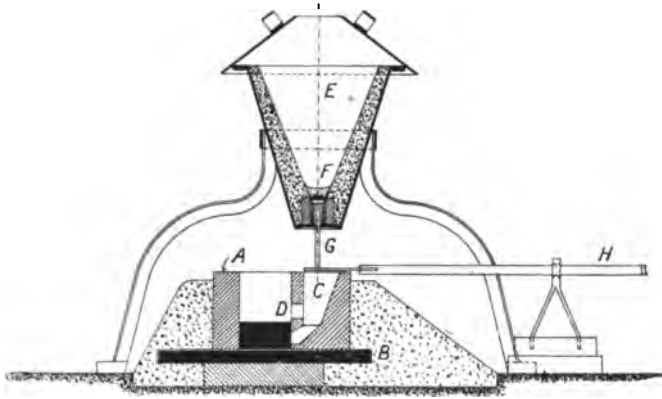

FIG. 74.—Thermite Welding Process.

not been fulfilled, the new metal being deficient in strength and reliability. It is useful in special cases, where lightness rather than strength is the chief desideratum. In the form of sheet it is used in place of stone for lithographic work, and when alloyed with copper or nickel is extensively employed for gear boxes and crank chambers of motor cars. It is very malleable, and is said to be exceeded only by gold and silver in this respect. In the soft state, it can be spun, stamped, or pressed into almost any shape required, which property has been utilised in producing cooking utensils, and domestic and fancy articles of all kinds. It is troublesome to work, and can only be turned, drilled, or machined with difficulty, and by the use of special methods. It may be cast either in sand or metal moulds, but the contraction

or shrinkage is considerable, being about twice that of brass, and sound castings are not easy to obtain. Aluminium has been successfully used in steel manufacture, for the purpose of preventing porosity, and the heat evolved by the burning metal has been turned to account by adding a small quantity from time to time to a ladle full of molten cast iron which it is desired to protect from excessive cooling.

The same principle has been applied in the *Thermite Welding Process* of Dr. Goldschmidt, introduced into this country by Thermit Ltd. of London, and extensively used for joining tramway rails, repairing broken shafts, cast steel parts, etc. A mould, A (Fig. 74), of fireclay or other refractory material is formed on a plate, B, round the joint to be made. A crucible, E, of conical form, carried on a tripod, is arranged immediately over the pouring gate, C, of the mould. The crucible is lined with magnesia, and is fitted at its lower end with a block of magnesia stone, inside which is a renewable tube or thimble of the same material. In the bottom of the crucible is placed an asbestos washer, on which is laid a small disc of iron. This is covered with a thin layer of magnesia sand to form a sort of stopping, F, which can be easily penetrated by the tapping pin, G, when the lever, H, is depressed. Finely divided aluminium intimately mixed with iron oxide is charged into the crucible, and is ignited from the top by means of a fuse of barium oxide and powdered aluminium into which a red hot iron is inserted. When the reaction is complete, so great is the heat produced, that on tapping the liquid "thermite" into the mould, the ends to be joined are raised to welding temperature in about a couple of minutes. The slag formed in the crucible during the reaction is utilised as a heat-retaining covering, and for this purpose is allowed to overflow through the opening, D, immediately over the joint.

The chemical reaction occurring is simply

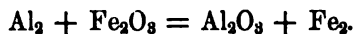

Aluminium exists very abundantly in nature in the various modifications of clay, and as silicate in felspar, granite, porphyry, etc. It also occurs in emery and corundum (Al_2O_3), and with sodium, as a double fluoride ($\text{Al}_2\text{F}_6 \cdot 6 \text{NaF}$) in cryolite, large deposits of which are found in Greenland. Aluminium is now

produced entirely by electrolysis, the process used in many parts of the world being that due to Héroult. The metal is obtained by decomposing alumina (Al_2O_3), which, however, remains infusible at extremely high temperatures, and which must therefore be dissolved in some substance capable of being melted and retained in the liquid state by the heat of the electric current. Héroult showed that this could be effected by using a solution of alumina in a mixture of sodium and aluminium fluorides. At Foyers, in Scotland, the process is being worked on a large scale, over 3,000 H.P. being obtained from the celebrated falls adjoining. The alumina used is a very fine clay known as bauxite, which is brought from Larne, in Ireland. This is fused with natural cryolite in a crucible of highly refractory material, carbon being invariably selected. The carbon crucible, enclosed in an iron casing, forms the cathode, and into it may be lowered the anode, consisting of a number of rods of gas retort carbon. With the poles in contact, cryolite is thrown in, and the current being switched on, the anode is raised. As the salt is fused, more is added until the proper quantity is reached, when the alumina is stirred in, and the bath covered with a layer of charcoal. The alumina is now decomposed into its constituent elements, and as the temperature of the bath is about 1700°F. , the molten metal sinks to the bottom, and is tapped out. The oxygen set free at the same time, unites with the carbon of the anode to form carbonic oxide, which burns upon the surface. The amount of energy required to liberate 1 lb. of aluminium is about 5 H.P. hours, and practically no loss of metal due to volatilisation, or in the form of slag, occurs. Only a low voltage is necessary, about 2.8 being theoretically required.

ANTIMONY.

Antimony may be regarded as one of the minor metals, being used only in the preparation of alloys. It is a lustrous bluish-white metal, highly crystalline, and exceedingly brittle. It melts at 1120°F. and expands on solidification, the surface acquiring a peculiar fern-like appearance. It is the most electro-negative element, and finds an important use for thermo-electric purposes. The only ore of any consequence is stibnite or antimony glance, Sb_2S_3 , almost the whole of which is raised in

France and Italy. The sulphide is reduced by heating with metallic iron in crucibles :—

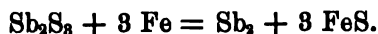

Any slight excess of iron dissolves in the antimony, and the crude metal is purified by fusion with more stibnite and common salt or potash as a flux.

NICKEL.

Nickel is a yellowish-white metal, rather harder than copper, and of about the same strength, but somewhat less ductility. It closely resembles iron in several of its properties, being malleable and weldable, and perceptibly magnetic, but unlike iron it is little affected by dilute acids, is far less readily oxidisable, and deteriorates much less rapidly under atmospheric influences. For this reason articles of iron and steel are frequently nickel-plated to protect them from rusting. Nickel melts at 2640° F., but in the pure state it is difficult to cast on account of the gases evolved in cooling. This is prevented to a considerable extent by the addition of a very small quantity of magnesium, which also has the effect of increasing the malleability of the metal. Nickel treated in this way is much used for cooking utensils, and other vessels for heating and boiling. The only ore of nickel worked for that metal alone, and on which the supply at present mainly depends, is a silicate known as garnierite, found in large quantities in Nova Scotia. It is reduced in a small blast furnace, using gypsum or alkali waste as a flux. The resulting *matte* is a mixture of nickel and iron sulphides, from which the iron is removed by taking advantage of its superior affinity for oxygen by alternate roasting and fusion in a reducing atmosphere, as in copper smelting. The iron oxide produced combines with the silica and escapes as slag, the nickel sulphide being subsequently roasted to oxide, and reduced by strongly heating with lampblack and oil. Perfectly pure nickel can only be produced by means of a wet process, during which the various impurities are precipitated in turn.

CHAPTER XIV.

COPPER-ZINC ALLOYS.

Brass is an alloy of copper and zinc, but small quantities of other metals, notably tin and lead, are sometimes added for special purposes. Copper and zinc alloy well in proportions ranging from 90 to 40 per cent. of the former metal. The brasses will thus be found to possess widely differing properties, which are clearly shown in the accompanying figures. Regarded as a mechanical mixture, it might be expected that the specific gravity, G , of an alloy composed of two metals of specific gravities g_1 , and g_2 , respectively, in the proportion of p_1 , and p_2 , per cent. would be found by the formula

$$G = \frac{(g_1 \times p_1) + (g_2 \times p_2)}{100}$$

The value of G does not, however, appear to follow any regular law, being sometimes greater, and sometimes less, than the average indicated by the formula, as shown by the curve, Fig. 75. It may be said that most of the properties are increased as zinc is added, reaching a maximum and then suddenly falling off. The maximum tensile strength, which for cast brass may be about 22 tons per square inch, is reached with 55 per cent. of copper, Fig. 76. Ductility as represented by elongation is at a maximum with about 70 per cent. of copper, Fig. 77. This explains why an alloy of 70 per cent. copper and 30 per cent. zinc is generally regarded as the strongest and most useful of the brasses. This alloy has been adopted as the *Standard Brass* for rolling into sheets, or drawing into tubes for locomotive and other purposes where the highest quality is required with the maximum resistance to corrosion. The tensile strength falls off very rapidly with increase in the amount of zinc, and a brass containing from 60 to 70 per cent. of zinc is extremely weak.

With a little less than 70 per cent. copper a point is reached where there is danger of the separation of the first eutectic, with

consequent loss of ductility. With proportions between 60 and 45 per cent. copper, the alloy again solidifies as a whole, until when the latter is reached, a second eutectic separates out. To this group belongs yellow metal, or *Muntz' Metal*, which contains

COPPER-ZINC ALLOYS

		COMPOSITION									
ZINC	0	10	20	30	40	50	60	70	80	90	100% ZINC
COPPER	100	90	80	70	60	50	40	30	20	10	0% COPPER

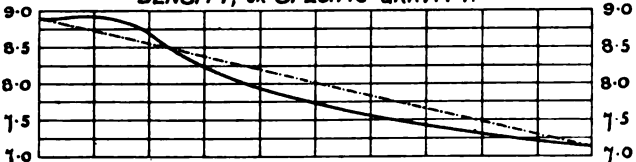

FIG. 75.

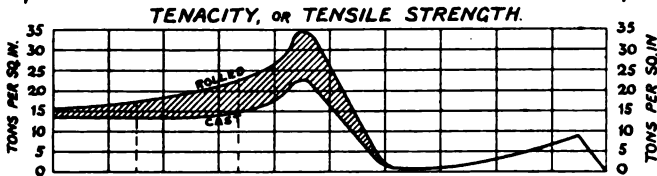

FIG. 76.

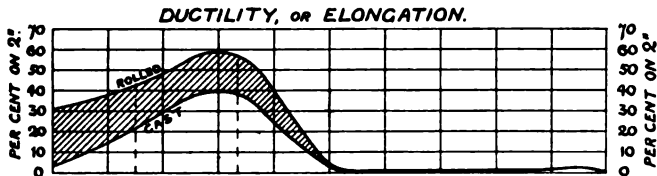

FIG. 77.

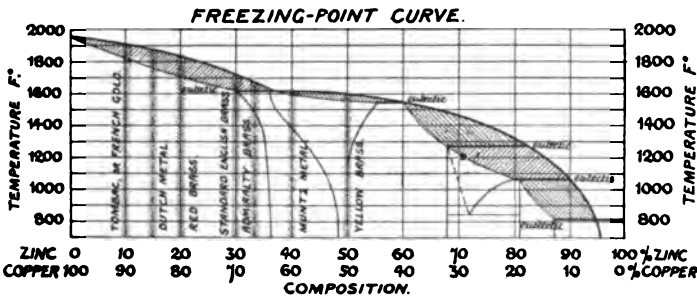

FIG. 78.

60 per cent. copper and 40 per cent. zinc, and which may be rolled at a red heat. Its average tensile strength is about 22 tons per square inch, and as it is little affected by salt water it is much used for the manufacture of ship's fittings.

The freezing point curve for the brasses is given in Fig. 78,

those portions of the diagram where eutectics are formed being shown shaded. It has been proved that eutectics which are more fusible than the mass of alloy in which they occur are sources of weakness, and in the case of eutectics with comparatively high melting points, considerable diminution in the ductility of the alloy is sure to occur, even if the strength be not markedly affected. It is therefore of importance to note that all the practically useful brass alloys fall within the limits of the unshaded portions of the diagram where the metal solidifies as a whole.

Influence of Impurities, and of Metals sometimes added to Brass.—As copper usually contains traces of arsenic, antimony, and bismuth, and as iron and lead may be similarly derived from the zinc, the effect of these impurities on brass should be noted. *Bismuth, Antimony, and Arsenic*, in the order named, exercise a very injurious influence on brass, rendering it hard and brittle, and liable to crack on rolling. None of these metals should be present in greater proportion than 0·01 per cent. *Lead* is frequently added to brass to the extent of 2 or 3 per cent., with the object of making the metal softer, and easier to turn or machine. At the same time, it reduces both strength and ductility, especially when cast. *Tin* in small quantity hardens brass, and somewhat increases the strength, but with loss of ductility. "Naval brass" used by the Admiralty for condenser tubes is composed of copper 70, zinc 29, and tin 1 per cent. It is doubtful if the use of this small quantity of tin is attended with any real advantage. *Phosphorus, manganese, and silicon* are sometimes added to brass, and seem to act by removing oxide of copper which is often found mixed with copper, rendering it "dry" and brittle. By deoxidising the copper, the density and homogeneity of the alloy are considerably increased. *Manganese bronze* (or more correctly speaking, manganese brass) is obtained by adding manganese to ordinary brass, the following being the composition for maximum strength: Copper 60, zinc 35, manganese 5 per cent. It can be forged and rolled hot, and has a tenacity of from 24 tons per square inch when cast, to about 30 tons per square inch after rolling. *Delta Metal* is brass to which a small proportion of iron has been added. Mr. Alexander Dick, who first produced delta metal (so called after the initial letter of his name) discovered that iron dissolves

to a considerable extent in molten zinc, forming a hard alloy. The iron in delta metal is introduced by adding this alloy to copper in the proper proportion. It is believed that the presence of the iron prevents the formation of a eutectic which would otherwise separate out at a comparatively low temperature. The alloy possesses a fine golden yellow colour, and is of exceptional strength and toughness. It can be melted with great facility, and produces perfectly sound and homogeneous castings. It becomes soft and highly malleable at a dull red heat, and may be readily forged, rolled, or stamped. The strength when cast ranges from 25 to 40 tons per square inch according to its composition, and the elongation from 35 to 15 per cent. on an original length of 8 inches. It is not attacked by sea water, and is therefore much used for parts of marine engines, screw propellers, ordnance, chemical, hydraulic and mining plants, sanitary fittings, etc.

Composition of Copper-Zinc Alloys.

Constituent.	Common Brass, 2/1 or Basis Alloy.	Standard Brass, 70/30 Alloy.	Naval Brass.	Muntz Metal.	Delta Metal.	Manganese Bronze.
Copper . . .	66·7%	70·0%	70·0%	60·0%	55%	60·0%
Zinc . . .	32·55	29·25	29·0	40·0	41·0	35·0
Lead . . .	} not more than a total of	} not more than a total of	—	—	2·0	—
Tin . . .			1·0	—	—	—
Iron . . .			—	—	2·0	—
Manganese	0·75%	0·75%	—	—	—	5·0

CHAPTER XV.

COPPER-TIN ALLOYS.

Gun-metal, or Bronze, is an alloy of copper and tin, although as in the case of brass, a small quantity of a third metal, such as lead or zinc, is sometimes added to soften the alloy. Tin exercises a much greater influence than zinc in modifying the properties of copper, and hence the range in composition of bronze is considerably less than that of brass. The red colour of copper rapidly disappears as tin is added, until with 80 per cent. or more of the latter metal, the alloy appears white. Speculum metal, used for mirrors and reflectors, contains 66 per cent. of copper and 34 per cent. tin, and closely resembles silver when polished. The specific gravity of gun-metal is greater than the mean of its constituents, due to contraction of volume which occurs on mixing, Fig. 79. The addition of a small percentage of tin gives an alloy possessing great strength and hardness, but if the amount of tin exceeds 20 per cent. a considerable decrease in strength occurs, as shown in the diagram, Fig. 80. It will be seen that the maximum ductility is obtained with 2 per cent. of copper, and that with 20 per cent. it disappears almost altogether until 80 per cent. is reached, when it again gradually increases to about its maximum value, Fig. 81. The absence of ductility, and consequent brittleness of those alloys containing from 20 to 80 per cent. copper, is very marked. The freezing-point curve, Fig. 82, is very complex, showing a set of subsidiary freezing-points occurring far below the main freezing-point curve, and it is these subsidiary freezing-points which mainly influence the mechanical properties of the metal. No alloy containing more than 5 per cent. tin solidifies as a whole, and as the amount of tin is increased, the alloy has two constituents which freeze at different temperatures. With from 10 to 20 per cent. of tin there are three distinct freezing-points, or in other words, the alloy solidifies in three separate portions. Alloys containing 40 per cent. tin have no less than four distinct freezing-points.

With from 60 to 90 per cent. tin there are three, and even when only 3 per cent. copper remains, there are still two. It is there-

COPPER-TIN ALLOYS.

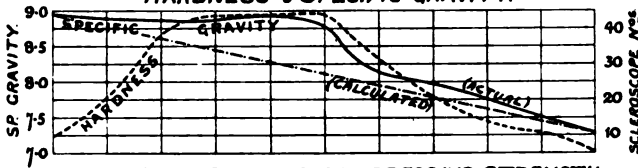

FIG. 79.

ULTIMATE TENSILE & COMPRESSIVE STRENGTH.

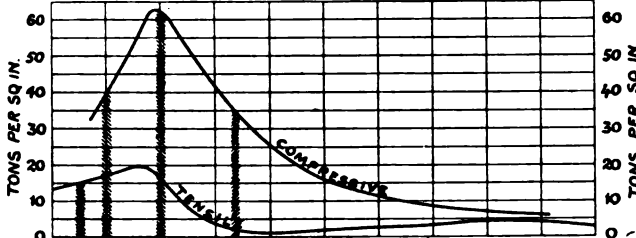

FIG. 80.

DUCTILITY, or ELONGATION.

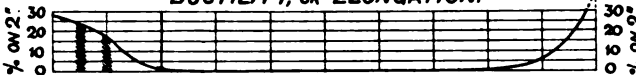

FIG. 81.

FREEZING-POINT CURVE.

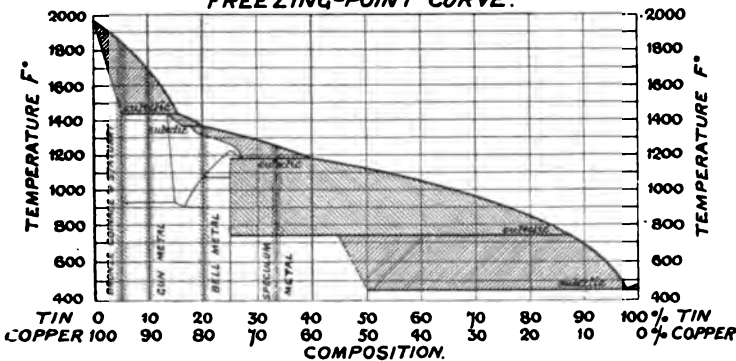

FIG. 82.

fore not surprising to find that in practical foundry work bronze is very liable to segregation, especially if the percentage of copper is low. It is regarded as very difficult to produce a truly homogeneous bronze alloy, and castings frequently show great irregu-

larity, the fracture of the metal exhibiting patches or "tin spots," interspersed throughout the mass. The structure of the metal is considerably influenced by the rate of cooling, which, to secure uniformity and density, and to avoid segregation, should be effected as rapidly as possible after casting. There are only three copper-tin alloys of any commercial importance, and their composition, as determined from a consideration of the freezing-point curve, must be closely adhered to, if good results are to be obtained. *Gun-metal*, which contains 90 per cent. copper and 10 per cent. tin, represents the strongest alloy. Maximum ductility, on the other hand, is obtained with 95 per cent. copper and 5 per cent. tin, which is the composition of copper coinage. For statuary, a mixture which will cast well and take a sharp impression is the chief requirement, and this may be secured by taking 94 per cent. copper and 6 per cent. tin. *Bell-metal*, which has the composition 80 per cent. copper and 20 per cent. tin, is hard and brittle, and extremely sonorous. *Speculum-metal* is a 2 to 1 alloy of copper and tin, or say 66 per cent. copper and 34 per cent. tin. It is of a silver-white colour, extremely hard and brittle, and capable of taking a high polish. Other metals in small quantity are occasionally added to bronze alloys, and it is said that zinc, when used in this way, causes the metal to mix better. *Engineer's Bronze* usually contains zinc in addition to copper and tin, the true bronze alloys being of comparatively limited application. For engine parts, steam fittings, hydraulic machinery, etc., an alloy of 88 per cent. copper, 10 per cent. tin, and 2 per cent. zinc is much used. The greatest difficulty which the founder experiences is due to the presence of oxides taken up in solution by the metal. In melting together copper and tin, the difference in fusibility is so great that care must be taken to prevent the tin being exposed to the air, especially as it is so much lighter than copper, and therefore tends to float upon the surface. Tin heated to redness and exposed to the air becomes rapidly oxidised, and is converted into peroxide, the substance known in commerce as "putty powder." To remove the oxide, a small quantity of some reducing agent such as phosphorus may be added to the alloy.

Phosphor Bronze usually contains about 0.1 per cent. phosphorus, which produces a very marked effect upon its properties, greatly increasing the tensile strength and ductility, and the

ability to resist shocks and repeated stresses. It is produced in several qualities, ranging from 22 to 35 tons per square inch ultimate tensile strength, the respective amounts of elongation being from 80 to 4 per cent. on 2 inches. It casts well, and may be rolled cold, or drawn into wire. By increasing the proportion of phosphorus to 1 per cent., a hard variety suitable for bearings, slide valves, etc., is obtained. Phosphor bronze castings giving an ultimate strength of 17 tons per square inch, and an elongation of 20 per cent. in 2 inches, have the composition copper 90 per cent., tin 9.7 per cent., and phosphorus 0.3 per cent. The phosphorus is introduced into the alloy in the form of phosphor-copper or phosphor-tin, the latter being preferable for general use. Sticks of phosphorus are placed in a bell-shaped graphite crucible, which is then immersed in molten tin. The phosphorus melts, and as it volatilises, it passes up through the tin, which in this way becomes saturated, about 6 lbs. of phosphorus being introduced into 100 lbs. of tin. The phosphor-tin is then cast into small sticks or bars, which permit of the proper quantity being added to the crucible after the copper and tin have been melted together in the usual way. Zinc must never be present in phosphor bronze, but it would appear that for bearing metal a certain proportion of lead is desirable. A useful mixture for this purpose is copper 80 per cent., tin 8 per cent., lead 10 per cent., phosphor-tin 2 per cent. (= 0.1 per cent. phosphorus).

Other Bronze Alloys.—*Aluminium Bronze* contains no tin, and is therefore, strictly speaking, a bronze only in name. The tensile strength and ductility of this alloy may exceed that of mild steel, and its elasticity and malleability are very remarkable. The maximum strength is obtained with 90 per cent. of copper and 10 per cent. aluminium. For sand castings this may reach from 30 to 50 tons per square inch, according to the method of cooling, whereas for rolled bars the average strength may amount to 38 tons per square inch, with an elongation of 60 per cent. on 2 inches. Castings of this metal are sound and not liable to segregation, but the aluminium used must be free from impurity, a small quantity of which is found to produce a very marked deterioration. Although the reduction in the price of aluminium has enabled this alloy to be produced at about the same price as ordinary bronze, it has not been much used. If

it be desired to take advantage of the low specific gravity of aluminium, nothing is to be gained by adding to it more than 4 per cent. of copper. With this proportion, the tensile strength is about 10 tons per square inch for castings, and 15 tons per square inch for worked bars. The elongation rapidly decreases with the addition of copper, the metal tending to become hard and brittle. As the quantities of the two metals approach equality, the resulting alloy has no commercial value whatever.

Silicon or Silicium Bronze is an ordinary bronze alloy to which silicon has been added with the same object as the phosphorus in phosphor-bronze, viz., of effecting the removal of any oxides of tin or copper dissolved in the alloy. The silicon forms a slag which floats upon the surface, very little of that element being left in the alloy. Silicon-bronze, which has a tensile strength reaching from 30 to 50 tons per square inch in the case of wire, resists corrosion due to atmospheric influences in a marked degree, and as its electrical conductivity much exceeds that of phosphor-bronze, it is largely used for telephone, etc., purposes in towns.

Nickel-Bronze or Cupro-Nickel.—Copper and nickel alloy well, and the metal is used largely for coinage, that of the United States and of Germany containing 75 per cent. copper and 25 per cent. nickel. It has also been employed for the sheath of rifle bullets, being drawn into tube with great facility. It is recognised as the best material for the blades of steam turbines, especially when working with highly-superheated steam.

Constantan.—For electrical purposes, it is often necessary to employ a metal having a high specific resistance, but which, at the same time, has a very small variation in resistance with change of temperature. Both these properties are possessed in a marked degree by an alloy of 50 per cent. copper, with 50 per cent. nickel, to which the name of constantan has been given. *Manganin*, consisting of copper 84 per cent., manganese 12 per cent., and nickel 4 per cent. is also used for the same purpose.

German silver is a triple alloy of copper, nickel, and zinc, of a white colour, which casts well, may be worked with ease, and is very malleable and ductile. The best composition to secure these

qualities is 50 per cent. copper, 20 per cent. nickel, and 30 per cent. zinc.

Tungsten Bronze.—An alloy of tungsten and copper known as *Platinoid* (although it contains no platinum) has a melting point of about 2200° F., and is much used in electrical work, and for valve seats and other parts of steam fittings subjected to high temperatures and for use with superheated steam.

Composition of Copper-Tin Alloys.

Constituent.	Gun Metal.	Bell Metal.	Speculum Metal.	Engineer's Bronze.	Phosphor Bronze (castings).	German Silver.
Copper . . .	90	80	66	88	90	50
Tin . . .	10	20	34	10	9.7	—
Zinc . . .	—	—	—	2	—	30
Nickel . . .	—	—	—	—	—	20
Phosphorus .	—	—	—	—	0.3	—

CHAPTER XVI.

WHITE METAL ALLOYS.

THE softer and more fusible metals, tin, zinc, lead, and antimony, form several series of alloys of great commercial value.

Tin and Lead produce alloys known as *Pewter*, and also the *soft solders* used by tinner and plumbers. Pewter contains 80 per cent. tin and 20 per cent. lead, and was formerly much employed for drinking vessels and other domestic appliances. Tinner's solder consists of equal parts of tin and lead, and best plumber's solder is composed of 2 parts lead to one part tin. An alloy to be used as a solder must not only be capable of uniting with each of the metals to be joined together, but it must also have a lower melting point than either, to obviate any danger of melting the metals. In this respect, the freezing-point curve of the lead-tin series is of special interest, Fig. 83. The addition of tin to lead lowers the freezing-point from that of pure lead, viz., 650° F., until at 356° F. a eutectic separates containing 68 per cent. tin. With further increase in the quantity of tin, the freezing-point rises to the melting temperature of pure tin, viz., 450° F. The eutectic contains a considerable portion of both tin and lead, and the eutectic line therefore extends both right and left of the freezing-point of the eutectic alloy. It will be seen that the alloy containing 66 per cent. lead begins to freeze at 467° F., and has a eutectic alloy at 356° F. Thus plumber's solder has two freezing-points, and upon this fact the operation of "wiping a joint" depends. The solder when used is in a pasty condition, due to its widely separated points of solidification, and in this state it consists of granules of solidified lead, containing some tin in solution, in a still fluid "mother-liquor."

Tin and Antimony alloy well in all proportions, the latter metal imparting hardness and ability to take a high polish without impairing the colour. The only alloy of this series of any commercial importance is *Britannia Metal*, which contains 90 per

cent. tin and 10 per cent. antimony, although other metals are sometimes added in small quantity. If the proportion of antimony does not exceed 10 per cent., the metal is very malleable, can be rolled cold, and may be cast, stamped, or spun with great facility.

Lead and Antimony form the basis of the *Type Metal* series of alloys, which are required to cast well and be capable of taking

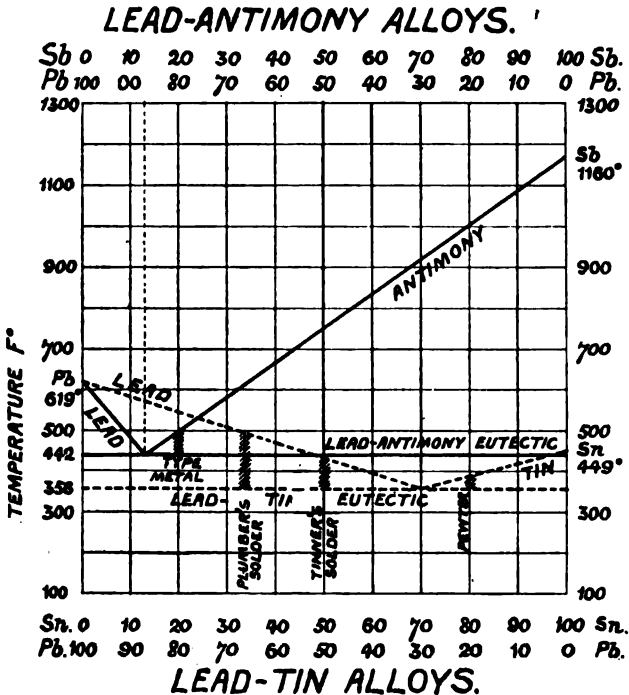

FIG. 83.

a sharp impression, whilst at the same time, the alloy must be sufficiently hard and strong to resist the pressure and wear due to printing. The usual composition of type metal is 80 per cent. lead and 20 per cent. antimony, but occasionally a small quantity of bismuth is added to lower the melting point and increase expansion on solidification. *Fusible Metal* consists of 50 per cent. bismuth, 25 per cent. lead, and 25 per cent. tin. It melts at 200° F., and is used for the fusible plugs of steam boilers. It

expands on cooling while still in a pasty condition, on which account it is found very suitable for taking impressions from dies, etc.

Anti-Friction Alloys and Bearing Metals.

Considerable success has attended the use of bearings lined with soft *White Metal*. Such metal must be of a plastic nature to accommodate itself to the form of the journal, so that to some extent it may flow under any excessive pressure until the journal bears uniformly over the whole surface. On the other hand, the "white metal" must not be too soft, or it will wear badly, and tend to cut. In any case it must be well supported by filling it into grooves or recesses in a shell of stronger metal, cast iron being generally employed for the purpose. The two halves of the shell are fixed together, and a mandril of the same size as the journal of the shaft is placed in position. The parts are then heated, and the white metal poured in. The alloy must therefore be readily fusible, and should expand slightly on cooling. It has been found that with a suitable alloy, both friction and wear may be much reduced. The chief characteristic of a bearing alloy is that it should consist of hard grains or particles to give a low co-efficient of friction, embedded in a softer matrix which acts like a cement, and which at the same time possesses the necessary plasticity to enable the bearing to adjust itself to the shaft. Alloys of lead and tin, to which antimony has been added, are frequently used as bearing metals. When examined under the microscope, such alloys are seen to consist of hard grains embedded in a tin-lead eutectic. At the same time brittleness must be avoided, and a compression test is useful as a means of discovering this defect, should it exist. One of the oldest and best known of the bearing alloys is *Babbitt's Metal*, which consists of 88 per cent. tin, 8 per cent. antimony, and 4 per cent. copper, although the normal proportions have in recent years been widely departed from by different makers. The addition of a small quantity of bismuth, not exceeding 0.25 per cent., is said to produce a very marked diminution in the co-efficient of friction. The alloy is, however, expensive, and attempts have been made to substitute cheaper metals for the costly tin without impairing the result. *Parson's White Brass* is composed of 68 per cent. tin, 30 per cent. zinc, 1 per cent. copper,

and 1 per cent lead. A lead-antimony alloy would appear to be the cheapest and most efficient white metal. Of this class, the best known example is *Magnolia Metal*, which consists of 80 per cent. lead and 20 per cent. antimony. When present in this proportion, the latter metal separates out, and appears in the form of hard crystals embedded in a matrix of lead.

Composition of White Metal Alloys.

Constituent.	Pewter.	Plumber's Solder.	Britannia Metal.	Type Metal.	Babbitt's Metal.	White Metal (Bearing).
Tin . .	80	34	90	—	87.75	—
Zinc . .	—	—	—	—	—	—
Lead . .	20	66	—	79.5	—	80
Copper .	—	—	—	—	4	—
Antimony	—	—	10	20.25	8	20
Bismuth .	—	—	—	0.25	0.25	—

CHAPTER XVII.

PROPERTIES AND USES OF THE PRINCIPAL VARIETIES OF TIMBER.

PLANTS are divisible into two great orders—flowering, and non-flowering, and the former may again be subdivided into outward-growing, and inward-growing. In the outward-growing, or exogenous variety, a new layer of material is added annually on the inner side of the bark, but in the case of inward-growing, or endogenous plants, such as the palm, bamboo, etc., new material

is added at the centre of the stem. Timber used for constructional or mechanical purposes is derived entirely from trees belonging to the exogenous subdivision of the phanerogamous or flowering order of plants. The cross section, Fig. 84, of the stem or trunk of such a tree consists of a number of concentric layers or "*annual rings*," each representing a year's growth.



FIG. 84.—Cross Section showing Annual Rings in Timber.

These are arranged round a central rod termed the *pith*, of which the original shoot coming from the seed was entirely composed. In the early stages of growth, the first formed layer of woody tissue known as the *medullary sheath*, is deposited upon the pith, which, having fulfilled its purpose, ceases to grow, and remains as a mere central rod or column. Outside the sheath are seen a number of fully-matured rings, clearly shown in the photograph, Fig. 85,

known as "duramen" or *heartwood*, and which in turn are surrounded by the last-formed rings, lighter in colour, of the

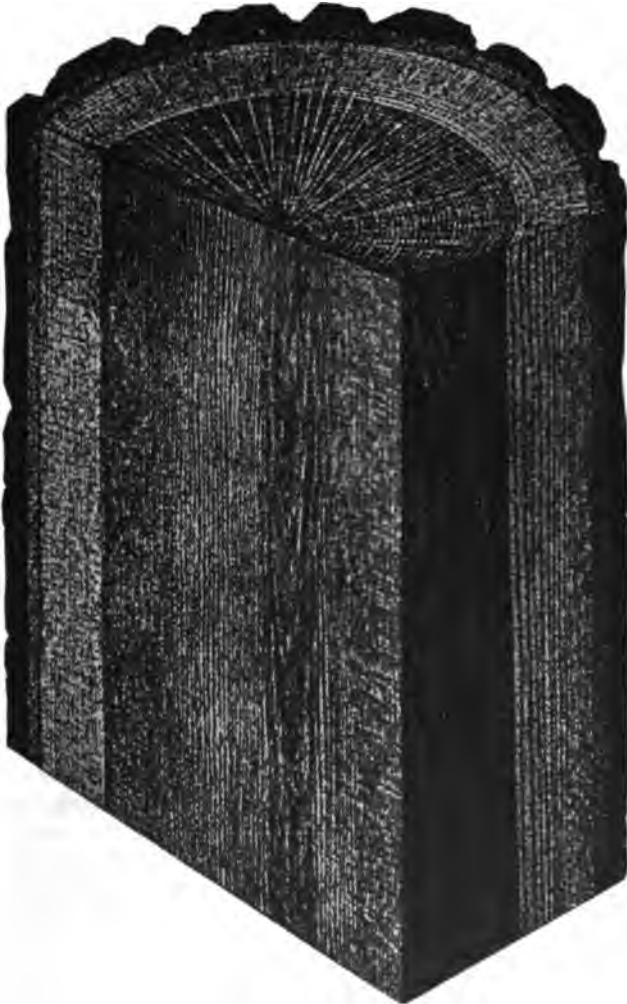

FIG. 85.—Cross, Radial, and Tangential Sections of Trunk of Tree.

"alburnum" or *sapwood*, through which the sap circulates in an upward direction. Encircling the sapwood is a thin layer known as the *cambium*, which is the extreme outer ring in process of

formation. Finally the *bark* constitutes the outer skin of the tree, and through its inner layers called the "liber," the downward current of sap returns. Each of the annual rings is composed of two portions, of which the inner one, light-coloured and soft, is the *spring wood*, and the outer one, darker and somewhat denser, is the *summer wood*. In the cross section, the annual layers are seen as rings, in a radial section they appear in the form of longitudinal stripes alternately light and dark, whereas in a tangential section the stripes are broader, occasionally showing V-shaped junctions, Fig. 85. The figure or "feathering" of pitch pine is obtained by cutting the boards in a direction tangential to the annual rings, thus exposing the vertical section seen in Fig. 85. The annual rings are formed in sections, and are



FIG. 86.—Longitudinal Structure of Stem.

composed of wedge-shaped bundles of longitudinal fibrous tubes, Fig. 86, which as they develop, compress the cellular mass of pith into thin strips, termed the *medullary rays*. These become the thin, hard, vertical plates radiating outwards from the heart towards the bark, which not only convey nourishment from the descending sap to the interior, but structurally serve to bind together the circular layers or rings. When skilfully exposed, as in working oak, beech, and plane tree, they are known as the "silver grain," but in soft woods the medullary rays are extremely fine, and are scarcely visible to the naked eye. The longitudinal arrangement of the woody fibre, taken in conjunction with the radial direction of the medullary rays, affords an explanation of the action which takes place in seasoning. The gradual drying-up of the sap causes the cellular or longitudinal part of the structure to

collapse, shrinkage taking place in the direction of the circumference of the annual rings. The stiff medullary rays, however, resist lateral contraction, and hence the shrinkage in a radial direction inwards towards the centre is very slight. If, then, the circumference contracts while the diameter of the tree remains the same, the timber must split radially in directions parallel to the medullary rays. Shrinkage which occurs after the timber is cut follows the same law, taking place in a circumferential direction round the tree. Suppose a log to be sawn into four quarters, Fig. 87, so that the angle bac is a right angle, and let the lengths of the sides ba and ac be measured before seasoning commences. When dry, it will be found that although the lengths ba and ac remain unaltered, the distance bc round the circumference will have contracted considerably, the angle bac being no longer a right angle. The change in shape due to shrinkage is shown in black on the right of the figure. Again, suppose that a number of parallel saw cuts are passed through the log, Fig. 88, the resulting planks which before seasoning are of uniform

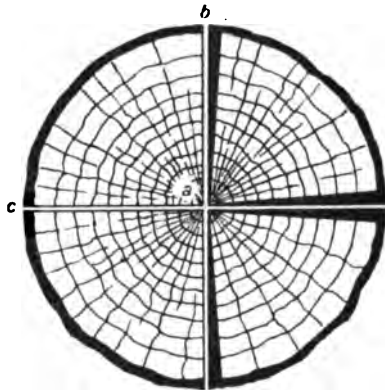

FIG. 87.—Shrinkage of Log Sawn into Quarters.

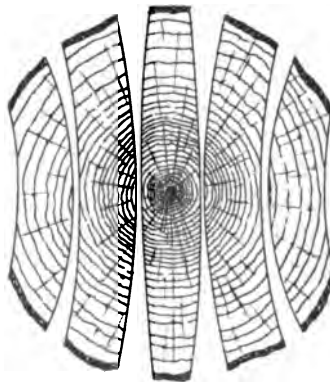
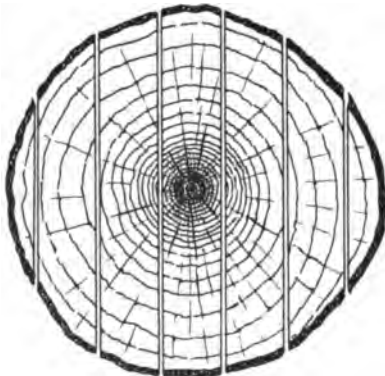

FIG. 88.—Shrinkage of Log with Parallel Saw Cuts.

thickness, will, when dry, appear as shown in the lower figure. The width of the centre plank and its thickness in the middle will remain unaltered, due to the resistance of the medullary rays, but the thickness at the edges will be reduced on account of the collapsing of the annual rings. The planks on each side of the centre will behave quite differently, although from the same cause. The thickness will be much less affected

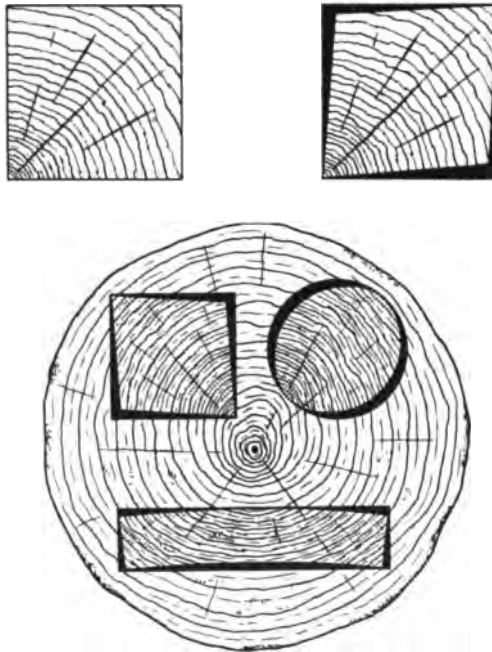

FIG. 89.—Warping and Shrinkage in Seasoning.

than in the case of the plank in the centre, but the side next the heart will become "round" or convex, and the outside "hollow" or concave, the breadth being considerably reduced. This action is known as "warping," the term being applied to cross or width bending, whilst sawn timber which has become bent in the direction of its length is said to be "cast." Warping is still more pronounced in the outer planks, in which, however, the reduction in thickness is comparatively small. It will thus be seen that in boards which are to remain flat, the annual rings

must run parallel to the edges, or at right angles to the face. Boards in which the rings are parallel to the face will invariably warp in seasoning. The same effect may be observed with a square scantling, or plank cut from a "quarter" near the outside. as in Fig. 89, the section on the left showing the original shape of the piece. Similarly, a cylindrical post turned out of a quartered log will shrink along one of the diagonals, becoming elliptical. When sawing up logs for seasoning, it is always advisable to cut through the heart if possible, otherwise by the same rule, there is danger of the sides splitting, as shown in Fig. 90. If a scantling of the required dimensions cannot be obtained without leaving in the heart, the log is frequently cut down the centre, and the two halves reversed and bolted together with the heart on the outside. In harder and stronger woods, such as oak, beech, etc., the effects of shrinkage are much more marked than in the soft fir timbers, but even in such cases the evils of shrinkage may be avoided by observance of the same general law.

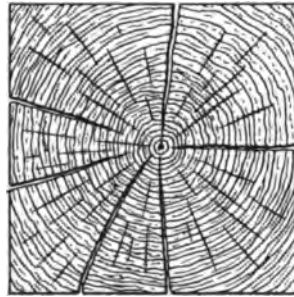

FIG. 90.—Splitting of Log in Seasoning.

Felling and Seasoning.—Timber trees should be felled when they have reached maturity. When too young, there is an excess of sapwood, and with too great age the wood deteriorates, and the heart commences to decay. The proper age is stated to be:—for oak, one hundred years; for spruce and pine, eighty years; for ash, larch and elm, about seventy years; and for poplar, forty years. Much of the timber imported into this country is cut down when the required size has been attained, without any regard to age, and for this reason it is becoming increasingly difficult to obtain really sound wood of any kind. The best time for felling timber is in midwinter, when the sap is at rest. On being felled, the tree is immediately stripped of its bark, and the branches lopped off, in which state it is known as a *log*. It is next roughly squared by axe or sawing, and becomes a *balk*. which is in a convenient form for storage, and does not split so readily as if left in the round. A newly-felled tree contains 50 per cent. of its weight of water in the form of sap and moisture

the greater part of which is in the sapwood. Before the wood is fit for use, the moisture must be thoroughly dried out, and various methods of *seasoning* are employed to effect this object. According to the so-called *natural method* of seasoning, the timber is stacked in sheds in such a position that the air may circulate freely all round it, but at the same time it must be protected from the sun and wind, and the floor must be of some impervious material, and kept dry. The time required for natural seasoning is considerable, amounting to eighteen months or two years for deal, but the result is much more reliable, and the timber stronger and more durable, than when any artificial substitute is

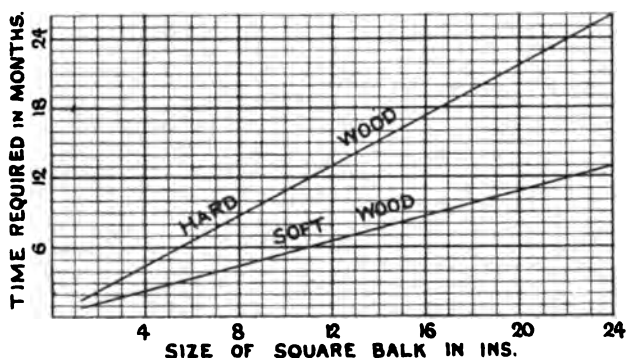

FIG. 91.—Average Time of Seasoning.

resorted to. Drying may be much more quickly effected by *water seasoning*, in which case, immediately after felling, the timber is entirely immersed for about a fortnight in a running stream. In this way, the sap is washed out, with the result that the timber when stacked in the usual way, dries in much less time than when the sap is left in. *Boiling and steaming* enable the removal of the sap to be carried out with still greater rapidity, one hour being allowed for every inch in thickness, and the subsequent drying, especially after steaming, is greatly accelerated. It is also claimed that this process will destroy the spores of dry rot, fungus, or other disease. *Desiccation or hot-air seasoning*, may be applied to small scantlings, and takes only a few weeks. The timber is stacked in ovens, through which a current of air, maintained at a constant temperature of 120° F. by utilising the waste heat from a steam boiler, is blown by means of a fan. Much of

the pitch pine imported into this country from the United States is first treated in this way. *Smoke drying* by means of a fire of chips and shavings is sometimes employed to facilitate seasoning, and is said to render the wood proof against the attacks of worms. Hard wood requires much longer time to season than deal. The average period for square scantlings of both hard and soft woods is shown in Fig. 91, and for planks one half to two-thirds the time indicated may be allowed. Many woods require a *second seasoning* after they have been worked, and it is for this reason that doors, window sashes, etc., should be allowed to stand some time after being made before they are wedged up and completed.

It has been found that the amount of moisture present in pine and fir timber in the condition naturally assumed by simple exposure to the air is equal to 15 per cent. of the weight of the dry wood.

Conversion and Market Forms of Timber.—The operation of cutting up a log or balk into smaller sizes is known as conversion. Imported timber is converted to market forms either in the forest as in America, or at the port of shipment, as is usual in Europe. Converted timber which has been reduced to smaller sizes in this country is said to be *re-sawn*. The following are the various forms to which timber is converted for the market :—

Hardwoods.

Log is the trunk with the branches lopped off.

Softwoods.

A balk, or squared timber, is a roughly-squared log.

A plank is a piece cut to rectangular section 11 inches wide.

A deal is a piece cut to rectangular section 9 inches wide.

A batten is a piece cut to rectangular section 7 inches wide.

A board is a thin piece of any width, but less than 2 inches thick.

Whole timber is an uncut balk.

A flitch is half a balk which has been cut in two lengthways.

Die-square stuff is timber cut to equal dimensions, from 5 inches \times 5 inches to 9 inches \times 9 inches.

Quartering is timber cut to square section, 3 inches \times 3 inches to 4 inches \times 4 inches.

Scantling is a piece sawn on all sides.

A pole is a straight trunk free from branches, 8 inches greatest diameter.

A mast is a long straight trunk, lopped and barked, diameter exceeding 8 inches.

It is to be feared that in cutting up the soft timbers at the present

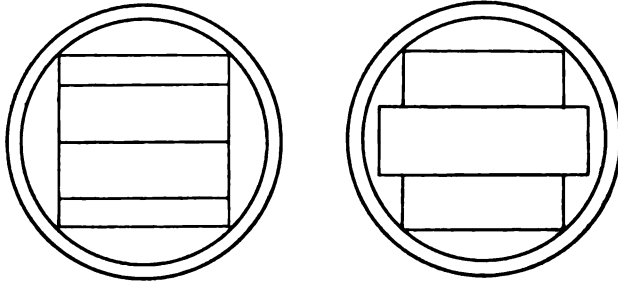

FIG. 92.—Conversion to Deals and Battens.

day the only consideration is to obtain as many marketable sizes as possible out of a given log. Two methods of converting fir timber into deals and battens as practised in Norway and Sweden are given in Fig. 92. In the first, four deals are

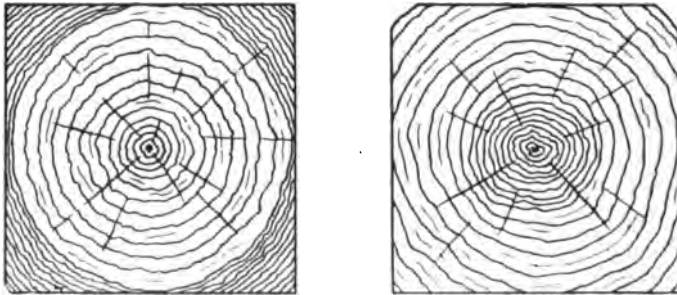

FIG. 93.—Production of "Waney" Edges.

obtained from the same log, and although the heart comes upon the surface, the better course would be to remove the pith altogether by cutting out a thin board. The outer deals are composed almost entirely of sapwood, and must inevitably warp, as before explained. So great is the desire to avoid waste, that they are also liable to run out beyond the bark at the corners,

exposing the defect known as “waney” edges, Fig. 93. The second method, Fig. 92, is still more objectionable, as the heart is left in the middle of the deal cut from the centre, which is therefore particularly liable to dry rot due to the early decay of the pith.

As already shown, floor boards should be cut as nearly as possible radially from the centre, the rest of the material being utilised for other purposes. This is shown in Fig. 94. The method of converting a quartered log of oak is given in Fig. 95. The best boards are obtained as at A, but this method entails great waste, unless thick boards are required as at D. Thick planks may

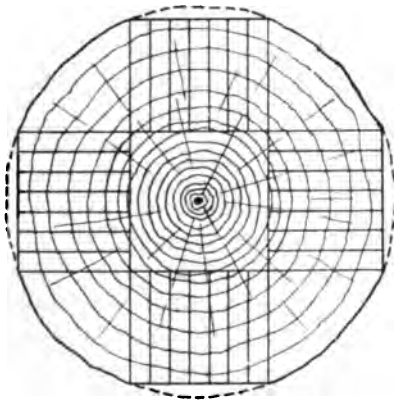

FIG. 94.—Conversion to Floor Boards.

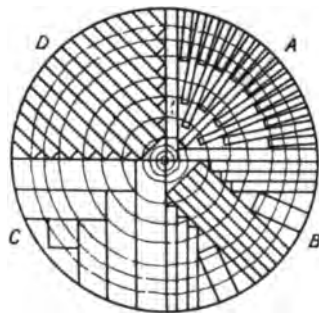

FIG. 95.—Conversion of Quartered Log.

be cut economically as at C, and a combination of the two methods is sometimes adopted as at B.

Quartering is usually resorted to with oak and other ornamental hard woods for the purpose of displaying the medullary rays, and to get rid of the pith or centre, which is often defective. When cut through the heart and the corners sawn off, as in Fig. 96, oak logs are known as *wainscot*, from which as shown, or from a quarter as at A, *wainscot boards* are obtained. Such boards must be cut parallel to the medullary rays, which come out on the surface in an irregular figure, producing the silver grain. The “feathering” shown in planks of pitch pine is produced by cutting tangentially to the annual rings as at B.

Defects in Timber.—A tree during growth is liable to many diseases, which may seriously affect the strength and quality of

the timber obtained from it. *Shakes*, which are common to almost every kind of timber, are longitudinal splits or cracks, running from the heart towards the sapwood. They are due to the shrinkage or decay of the interior of the tree, and generally occur in trees past maturity. There are several varieties of

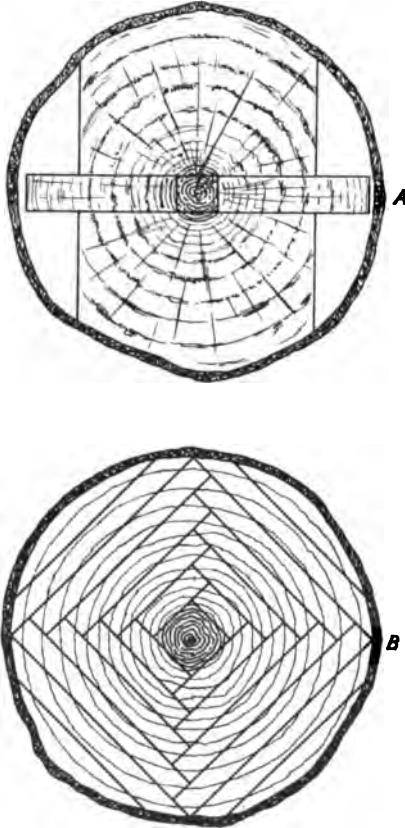

FIG. 96.—Wainscot.

shakes, all of which are sources of weakness, and as they are liable to escape detection when in the form of extremely fine cracks, they constitute a possible element of danger. The *heartshake* is probably the commonest defect in timber. Should it occur as a single cleft across the tree as at Fig. 97 A, it need not be the cause of much waste in conversion, but with two clefts at right angles, as at B, scantlings larger than quarters cannot be obtained. Trees are sometimes found to twist during growth, in which case a heartshake may take a spiral course, rendering the timber quite unfit for conversion. *Starshake*, Fig. 97 C, is a similar and more serious defect, with a number of splits radiating from the centre to the circumference. *Ring*, or *cupshake*, Fig. 97 D, consists

of a curved split between the annual rings, and as a rule is not so serious as heartshake. *Knots*, which constitute a very common defect, occur at the junction of the branches with the stem, and are classed as either live or dead. The first kind are formed by branches which were living when the tree was felled, and unless very large, are less objectionable

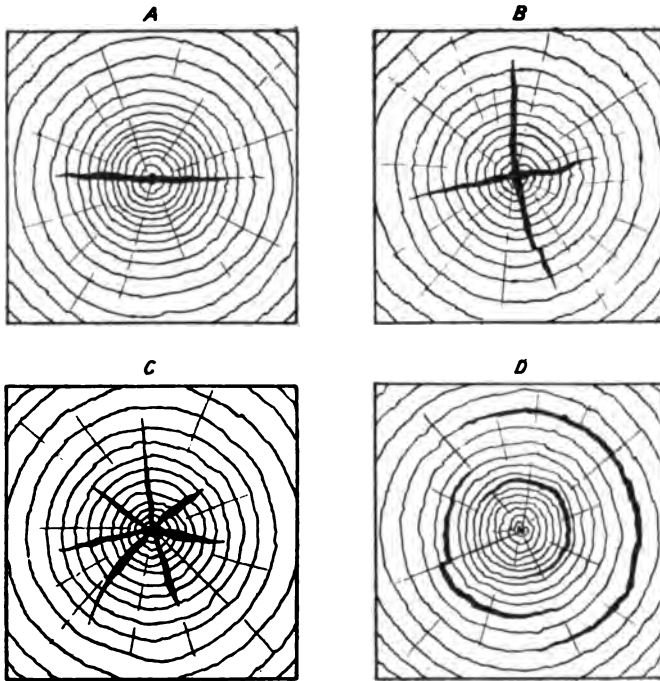

FIG. 97.—Varieties of Shakes in Timber.

than *dead knots*, which are often loose and ready to fall out, and will usually lead to the timber being rejected. A *rindgall* is a curved swelling covering up the wound caused by breaking or imperfectly lopping off a branch, and resembles a knot in its effect upon the strength of the timber containing it. An *upset*, Fig. 98, is a distortion of the fibres across the grain of the wood, said to be due to unskilful felling. The part thus affected will break through with little resistance, much as if the fibres had

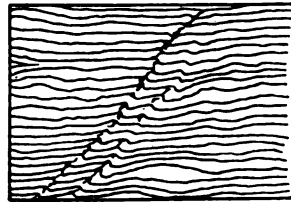

FIG. 98.—Upset in Timber.

been severed. *Decay in timber* is due to putrefaction, or fermentation, which proceeds with the evolution of a considerable quantity of gas, chiefly carbon dioxide and hydrogen. Two forms of decay are

frequently met with, known respectively as *wet rot* and *dry rot*. The former occurs in the growing tree, or in situations where timber is alternately exposed to moisture and dryness, the wood being finally reduced to a powdery brown mass with an unpleasant odour. Dry rot takes place only after the wood is dead, and may be said briefly to be due to lack of ventilation. It is caused by the growth of a fungus, which thrives in warm, moderately damp, stagnant air, the wood becoming mouldy, and emitting a musty smell. An apparently sound log may be full of dry rot inside.

Preservation of Timber.—Perfectly seasoned wood, if not protected by tar or paint, will not stand exposure to the English climate for more than about twenty-five years. Painting or tarring may prevent decay if the wood has been thoroughly seasoned previously. This is essential, as otherwise the filling-up of the outer pores prevents the escape of moisture, and by inducing decay, does more harm than good. As charcoal possesses powerful antiseptic properties, the lower ends of timber to be embedded in the ground are first burnt or charred, to prevent dry rot and the attacks of worms. A number of processes have been introduced with the object of preserving timber from decay, by driving out the sap and forcing in some chemical solution which will coagulate the albumen of the wood, and, by destroying insects, worms, fungi, etc., prevent dry rot. Probably the most successful process is that introduced by Bethell, and known as *creosoting*. The timber after drying, is placed in a cylindrical vessel about 7 feet diameter and 60 feet long, resembling the shell of a boiler, a door at one end is closed airtight, and a vacuum of 7 or 8 lbs. per square inch created by means of a pump. Creosote, or "oil of tar," which is a thick, dark brown liquid obtained from coal tar by distillation, is then admitted at a temperature of 120° F., and the pressure is raised to about 150 lbs. per square inch. The amount of creosote taken up depends largely upon the nature and quality of the timber, and the proportion of sapwood present. The process answers well for soft wood, such as railway sleepers, street paving, etc., which absorb from 10 to 12 lbs. per cubic foot. Hard wood, such as oak, will not take up more than 2 to 3 lbs. per cubic foot, and pitch pine is almost impenetrable. The most effective of these impregnation methods is without doubt that known, after the

name of its inventor, as Kyan's process, or *kyanising*, which consists in immersing the timber in a solution of 1 part corrosive sublimate (bichloride of mercury) in 100 parts of water. The substance is an exceedingly dangerous poison, and is most efficient in destroying all traces of organic life. It thus prevents fermentation, and will even check the spread of dry rot in timber already affected with that disease. As however the salt is somewhat costly, the process has had but a limited application. In the *burnettising* process, introduced by Sir W. Burnett, the timber is allowed to soak in a strong solution of zinc chloride, which is cheaper than mercury, and fairly effective in destroying both germs and parasites. The *boucherising* process, used in France for railway sleepers, is conducted in a manner similar to the preceding, a solution of copper sulphate being employed. This has the doubtful merit of cheapness, and the preservative, being readily soluble in water, is rapidly washed out by rain.

Classification and Varieties of Timber.—All timber used in construction is classed for commercial purposes as either soft or hard. The *soft woods* comprise all trees of the coniferous variety, such as the pines, firs and spruces, the seeds of which are produced as cones. The leaves of this class are spinous or needle-like, and the wood, which is resinous and generally contains turpentine, is light in colour. The annual rings are very distinct, but the medullary rays are scarcely visible. The *hard woods*, such as teak, oak, mahogany, etc., are non-coniferous, and have broad leaves. The wood is usually dark coloured and non-resinous, any secretion being of an acid or astringent character. The annual rings are indistinct, but the medullary rays are easily discerned.

SOFT WOODS.

Pine and Fir Wood.—Much confusion exists in the naming of all soft woods, owing to the custom of confounding the pines and the firs, which belong to totally distinct species, and also of naming timber after the port of shipment.

Northern Pine (*Pinus sylvestris*), also called Scotch fir, is commonly known as *redwood*. It is imported from the Baltic, and from Norway and Sweden, in barks from 10 to 20 inches square, and from 30 to 40 feet long, and also in the form

of planks, deals, and battens. It is very extensively employed in this country for railway sleepers. Riga, Memel, and Danzig balk timber is the most suitable for piles, structural work, etc.

White Fir or Spruce (*Abies excelsa*), generally known as *white deal*, is imported from Christiania, Onega, and Petrograd. It is knotty, and inferior to redwood in strength, and is liable to warp. It is largely used for scaffold poles, floor boards, packing cases, and the commoner descriptions of joinery.

Yellow Pine (*Pinus strobus*), imported from Quebec and other ports in North America, is straight grained, free from knots, and easily worked, and although not durable if exposed to the weather, is invaluable for joiner's work, and is the wood most largely used by engineers for pattern-making. It may be recognised by the short dark "hair lines" which are always found running in the direction of the grain.

Pitch Pine (*Pinus australis*), is imported from the Southern States of North America in logs from 10 to 18 inches square, and from 20 to 40 feet long, and also in planks 10 to 15 inches wide, and from 3 to 5 inches thick. It is a heavy, hard, and very strong wood, free from knots, but somewhat liable to split and shrink. It is full of resinous matter, which renders it very durable, but at the same time makes it difficult to work. As it is cheap, and can be obtained of great length, it is largely employed for the heaviest engineering work and in shipbuilding, and has come to be regarded as a substitute for Memel or Danzig timber. The annual rings are wide and strongly marked, and when properly cut, display a beautifully figured grain. For this reason, it has been much used for ornamental joinery. Turpentine is obtained from this tree by a process of tapping or "bleeding."

Larch (*Larix europæa*), is imported from Russia and North America, and is grown to some extent in this country. It is of a yellow colour, and is the toughest and most durable of the conifers. It is therefore much used for railway sleepers, and for posts, fencing, etc., exposed to the weather. On the other hand, it shrinks very much, and is very liable to warp.

Kauri Pine (*Dammara australis*), is obtained only from New Zealand, and can be had of very large size quite clean and free from knots and sap. It is strong and durable, straight

grained, and of silky appearance, producing very handsome joinery.

Lime or linden (*Tilia parvifolia*), is of pale yellow colour, soft and close grained. It cuts equally well with or across the grain, and is greatly valued for carving and cabinet making.

American Whitewood or **Canary** (*Liliodendron tulipifera*), is imported from New York in large planks from 2 to 3 feet in width, and of any reasonable length. It is soft, close, and straight in grain, very easily worked, and takes paint or polish very well. It is much used by cabinet makers, carriage builders, shop fitters, etc.

HARD WOODS.

Oak (*Quercus*). A large number of varieties of this timber, and of many degrees of quality, are found in this country, on the Continent, in America, etc. It has long been considered that British oak is on the whole superior to any other, but native-grown wood is now difficult to obtain, and several continental species, especially from Austro-Hungary, are probably quite as good, and are much cheaper. Oak possesses a combination of good qualities in a remarkable degree, and where strength, stiffness, toughness, and durability are required, it is unrivalled. It is much used in shipbuilding, and for heavy constructional work, and for the frames of railway carriages and wagons exposed to sudden shocks, it is invaluable. The colour when freshly cut is light fawn, turning dark brown, and ultimately nearly black, with age. No other wood is so suitable for durable carving, and on account of its rich colour and beautiful markings it is in great demand for high-class joinery and furniture. Oak contains gallic acid, which corrodes iron fastenings, and this reacting on the timber may set up dry rot. Oak bark is in great request for tanning leather.

Teak or Indian oak (*Tectona grandis*), has been much used as a substitute for oak, to which it is in many respects superior. It is imported from Moulmein and Rangoon in Burmah in logs from 10 to 30 inches square, and from 20 to 50 feet long. It resembles oak in appearance, but is stronger and stiffer, and it contains a considerable quantity of an essential oil which renders it very durable, and immune from the attacks of the white ant and other insects. For the same reason, it does not corrode iron

fastenings, the oil being, in fact, a preservative against rust. It is much used in shipbuilding, and is very durable when exposed to the weather.

Greenheart (*Nectandra rodiazo*), comes from British Guiana in logs from 12 to 24 inches square, and up to 60 feet in length, and on account of the essential oil which it contains, it successfully resists the attacks of sea worms and the white ant, and is probably the strongest and most durable timber in ordinary use. It is especially prized for dock gates, piers, piles, and marine works generally.

Mora (*Mora excelsa*), is a light-red timber from Guiana, very heavy, hard and strong, obtainable in logs from 12 to 20 inches square, and from 20 to 85 feet long. It is highly esteemed for dock gates, and in shipbuilding.

Lignum Vitæ (*Guaiacum officinale*), is an extremely hard and heavy timber which comes from the West Indies and Central America. It is in considerable demand for mallets and tool handles, and for the bearings of shafts which have to work under water, notable instances of its use being for the footsteps of turbines, and for the bearing of the after-length of the propeller-shaft of a steamship. Ordinary bearings are unsuitable for use under water, and the brasses wear away very rapidly on account of the difficulty of supplying the oil needed for lubrication. The portion of the propeller-shaft which passes through the bearing is encased in gunmetal to prevent oxidation, and runs on longitudinal strips of lignum vitæ dovetailed into the stern tube, water spaces being left between. Lubricated with water in this way, lignum vitæ forms a very good bearing, and is easily renewed.

Mahogany (*Swietenia mahogoni*), is a product of Central America, two varieties being distinguished as Honduras mahogany or baywood, and Spanish or Cuban. It does not shrink or warp much, and it has the property of holding glue better than any other wood. Mahogany is very durable when kept dry, but is quite unsuitable for exposure to the weather. It is easily worked, and takes a high polish. Baywood yields logs 12 to 24 inches square, and up to 40 feet long, and planks 6 feet wide may sometimes be obtained. It is of a light pink colour, but is rarely figured. It is much used in carriage building, and for joinery and cabinet work, as well as for internal work on board ship. Spanish mahogany is dark red brown in colour, and has a beautiful

wavy figure, in consequence of which it is in considerable demand for furniture. Mahogany is also imported from the West Coast of Africa in considerable quantity and of fair quality, for building purposes.

Jarrah, or Australian mahogany (*Eucalyptus marginata*), is shipped from West Australia in logs from 12 to 24 inches square, and from 40 to 60 feet long. It is a very heavy, hard, close-grained wood, extremely durable when sound, and therefore extensively used for street paving blocks, for which it has no equal.

Karri (*Eucalyptus diversicolor*), also known as "blue gum," somewhat resembling jarrah, is the giant tree of South-West Australia. It is dark red in colour, without figure, very hard and tough, but not so easily worked as jarrah. It is rather liable to gum veins and starshakes. It is also used for paving blocks and for railway sleepers.

Ash (*Fraxinus excelsior*), is widely distributed throughout Europe and North America. It is of light brown colour, and possesses the peculiarity of having no sapwood. It is chiefly remarkable for its great toughness and elasticity, which fit it for use wherever sudden shocks have to be sustained, as in felloes and spokes of wheels, shafts for carriages, tool handles, etc. It is remarkably durable when kept dry, and when white, is much sought after for furniture purposes. When exposed to wet, it rapidly decays.

Beech (*Fagus sylvatica*), is found throughout Great Britain and most parts of the Continent. The colour is brown, the annual rings are well marked, and the medullary rays very large and distinct. It is durable if kept either quite dry or constantly wet, but alternate exposure soon causes rot. It is much used for mallets, tool-handles, joiner's planes, the teeth of mortice wheels, for cabinet work, and for chairs.

Elm (*Ulmus campestris*), is a rough cross-grained wood, very tough, and liable to warp, but very difficult to split, on which account it is highly valued for such purposes as the naves of wheels, and other uses in coachbuilding. It is extremely durable when constantly immersed in water, and makes excellent piles for foundations, sluices, floats for paddlewheels, etc.

Hickory (*Hicoria ovata*), is exported in considerable quantity from the Eastern United States, and is regarded as the best of all woods for axe and hammer shafts, handles, etc.

Hornbeam (*Carpinus betulus*), is remarkable for its hard stringy fibre, and is superior to all other woods for the teeth of mortice wheels, mallets, and lasts.

List of the Most Useful Timbers for Different Purposes.

Heavy Engineering Construction.	Greenheart, teak, oak, pitch pine, Danzig fir.
Piles.	Elm, oak, pitch pine, blue gum, beech.
Durability when dry.	Oak, mahogany, cedar, yellow pine.
Wet situations.	Elm, greenheart, teak, oak, pitch pine, beech.
Railway sleepers.	Larch, creosoted Memel oak.
Paving blocks.	Jarrah, karri.
Carpentry (main structural work).	Douglas fir, Oregon pine.
Floors.	Archangel, Petrograd and Onega red deals; maple, pitch pine, and oak to resist great wear.
Interior joinery.	Kauri pine, American yellow pine, pitch pine, mahogany.
Ship joinery.	Walnut, mahogany.
Stair treads.	Teak, oak.
Tool handles.	Ash, beech, box.
Patternmaking.	Yellow pine, bay wood, American whitewood.
Wood carving, and engraving.	Lime, pear, kauri, sycamore, box.
Shafts and springs.	Ash, hickory, lance.
Rollers.	Lignum vitæ, box, mahogany.
Bearings for shafts under water.	Lignum vitæ.

Ultimate Strength and Weight of Timber.

Name.	Weight in lbs. per cubic foot.	Ultimate Strength in Tons per square inch.	
		Compression.	Tension.
Soft Woods :			
Larch	35	2.5	3.6
{ Northern Pine, or Scotch Fir			
{ Redwood	36	2.9	3.0
{ Red Deal			
{ Pitch Pine	48	3.5	3.2
{ Spruce or White Fir			
{ White Deal	30	2.6	2.9
{ Yellow Pine.	32	1.8	1.0
Hard Woods :			
Ash	48	3.0	4.5
{ American Whitewood			
{ Canary	26	1.5	2.3
{ Beech	48	3.5	4.3
{ Birch	45	3.2	—
{ Cedar	41	2.5	3.2
{ Ebony	35	3.2	—
{ Elm	36	3.7	4.3
{ Greenheart	65	6.3	4.0
{ Hickory	52	—	—
{ Honduras Mahogany			
{ Bay Wood	35	2.8	—
{ Hornbeam	47	3.5	7.1
{ Jarrah	63	3.2	5.2
{ Karri	61	3.0	4.8
{ Kauri, or New Zealand Pine	34	2.1	2.0
{ Lignum Vitæ	76	4.2	7.2
{ Lime	35	—	—
{ Maple	43	2.9	6.3
{ Mora	62	4.1	—
{ Oak	52	2.9	6.2
{ Spanish Mahogany	53	3.2	4.3
{ Teak	48	4.7	6.7
{ Walnut	46	3.4	—

CHAPTER XVIII.

PROPERTIES AND USES OF THE PRINCIPAL VARIETIES OF STONE, AND OF CEMENT, CONCRETE, ASPHALTE, ABRASIVE MATERIALS, ETC.

Stone.

In mechanical engineering and allied industries, stone is used to a limited extent, and only a brief consideration of the subject will be attempted. It is important that stone used in engineering work should possess certain properties, of which (1) durability, (2) hardness, (3) strength, and (4) weight, are the chief essentials.

Durability depends upon the chemical composition of the stone, its physical structure, the position in which it is placed and the nature of the surrounding atmosphere. Sulphuric acid contained in the air of towns, and carbonic acid present even in pure air, will slowly decompose a stone which consists largely of carbonate of lime or carbonate of magnesia. Stones containing much iron may be slowly disintegrated by reason of the oxidation of the metal. The structure of stone, especially as regards porosity, exercises a marked influence on its durability. A porous stone takes up a large amount of moisture, which on freezing, expands and disintegrates the surface, leaving a fresh portion to be acted upon subsequently. The smooth surface of polished marble may withstand atmospheric action for many years, whilst chalk, which has the same chemical composition, speedily crumbles away. Viewed in this light, it follows that a crystalline structure is, as a rule, to be preferred, and a close, fine grain may be taken to indicate lasting quality. Expansion and contraction, due to a wide variation in temperature, may bring about the opening of minute natural cracks or fissures, and thus lead to the partial destruction of the stone. Newly-cut stone should be *seasoned* by exposure to the air for some time before using, to get rid of the "quarry sap," or moisture which exists in the stone before removal from the bed in the quarry.

It is most important that all stone should be placed on its *natural bed*, that is, in the same position as that in which the strata were originally deposited. The object is to obtain the maximum strength to resist crushing, as well as the maximum resistance to disintegration due to the action of frost. All sedimentary rocks have been formed in layers, which must be placed at right angles to the direction of the pressure which comes upon them. If the load be applied to the stone with the laminae vertical, or with the grain "end on," its crushing strength is considerably reduced. In addition, if built in position with the layers parallel to the face of the wall, the stone will flake off layer by layer as the result of each succeeding frost. In ordinary walling, the laminae are arranged horizontally, but in all cases they must be placed with their edges at right angles to the face of the wall. In arches, the natural bed must come as nearly as possible at right angles to the direction of thrust, and perpendicular to the face of the arch. To ascertain if a stone has been laid on its natural bed the usual method is to brush away any stone dust and pour water on the surface, which, in many cases, will cause the lines of stratification to become visible. The mason is generally able to "feel" the direction of the grain when working the surface, but this "plane of easiest cleavage" does not always coincide with the natural bed. It is often extremely difficult, if not impossible, to distinguish the natural bed in a block of stone, and it is always best to have the stone marked at the quarry.

Hardness is a property of much importance for mechanical purposes, especially where stone is exposed to the effects of friction and wear, or of running or dripping water. Stone is usually softer in the "green" state when first quarried, becoming harder with seasoning. Hardness is the quality which more than any other affects the cost of the stone in working. For carving, a soft stone would naturally be selected, but as a rule, the hardest and densest stone, if uniform in texture, will be found most suitable for ordinary building and mechanical purposes.

Strength is often regarded as of secondary importance, but it should be borne in mind that although stone may be safely used in compression, it has very little transverse, and practically no tensile, strength. The compressive strength as determined by crushing 3-inch cubes in a testing machine, may be regarded as an index of general quality, and such tests afford a convenient means of ascer-

taining the suitability of a stone subjected to any excessive or unusual stresses. The safe load to which stone is subjected in any structure should not exceed one-tenth of its ultimate strength as determined by experiment, but in practice the actual load is usually very much less than this.

Weight is closely related to the density, and therefore the porosity of a stone, the effect of which has already been noticed. It is usual to test for porosity or absorption by immersing a sample in water for twenty-four hours, and noting the weight of water absorbed. The best stones, as a rule, absorb the least water, the average being for sandstone 10 per cent., limestone 17 per cent., and granite not more than 1 per cent. Weight is very often in itself a useful quality. Thus, for retaining walls, piers, columns and marine work, a heavy stone is required, whilst for parts which have merely to support their own weight, a light stone is to be preferred.

Classification of Stone.—The different varieties of stone used for constructional purposes are generally divided into two classes:—(1) igneous, and (2) aqueous or sedimentary. The *igneous rocks*, such as granite, are of volcanic origin, and have been produced in a state of fusion. The *sedimentary or stratified rocks*, such as sandstone and limestone, have been deposited in water, and subsequently subjected to enormous pressure due to the weight of the strata above. It has, however, been found more convenient in describing the composition, properties and uses of stone for mechanical purposes to adopt the following classification:—(1) Granites, (2) Slates, (3) Sandstones, and (4) Limestones.

Granite is usually composed of (a) felspar, which is an anhydrous silicate of alumina and potash having the composition $\text{Si}_3\text{O}_8(\text{KO})_2 \cdot \text{Al}_2\text{O}_6$, (b) mica, also an anhydrous silicate of alumina and potash of the formula $\text{K}_2\text{H} \cdot \text{Al}_3(\text{SiO}_4)_3$, and (c) quartz, or anhydrous silica, SiO_2 , variations in the proportions of these constituents producing wide differences in both colour and structure. The average proportions are:—felspar 40 to 50 per cent., quartz 40 to 30 per cent., and mica the remainder. Excess of felspar causes the rock to decompose rapidly on exposure to the weather, producing the china clay or kaolin, a hydrous silicate of alumina of the formula $\text{Al}_2\text{O}_3 \cdot 2\text{SiO}_2 \cdot 2\text{OH}_2$, found in Cornwall and Devonshire. From this it follows that

certain varieties of granite do not withstand the influences of air and water so irresistibly as is commonly supposed. The durability depends upon the quantity of quartz, and the nature of the felspar. Quartz is a hard, glassy, crystalline variety of silica, and if present in large proportion the granite is difficult to work, but will weather well. Mica is present in thin scales, which may be detached with a knife. It gives the glistening appearance to granite, but is easily decomposed, and is a source of weakness. In syenite, which is usually included under the term granite, hornblende, which is an anhydrous silicate of lime and magnesia, $5(\text{MgCa})\text{O} \cdot 6\text{SiO}_2$, takes the place of the mica, and imparts a darker colour. Igneous rocks other than granite are of little importance for engineering purposes. Granite possesses great strength, and will withstand rough usage and enormous wear. It is extensively used in engineering works such as docks, piers, breakwaters, lighthouses, bridges, etc., and is invaluable for any purpose where a heavy load is to be carried, or where weight and durability are the chief consideration. The harder varieties are also largely used for street paving, and for road metal. If of good quality, it is not much affected by acids, but the surface is found to suffer considerably from the effects of a high temperature. It is capable of taking a high polish, and on this account is much employed for decorative and monumental purposes. In mechanical engineering, it is used for the rollers of crushing mills, and for the runners and bed plates of edge runner mills for treating sugar, tartar, straw, paper, oilseeds, etc. The Scotch granites have a high reputation for strength, beauty, and durability, the best known varieties being the pink from Peterhead, the grey from Aberdeen, and the black and white from Dalbeattie. Cornish and Devonshire granites are mostly grey in colour, and are not so highly esteemed as the Scotch. The granites from Leicestershire and the Channel Isles are syenitic, and being very hard and difficult to dress, are suitable only for paving setts. Norwegian granite is now largely imported, and may be had in a variety of colours, red, grey, blue, and black.

Clay is a hydrated silicate of alumina, containing from 45 to 65 per cent. silica, 22 to 40 per cent. alumina, and from 5 to 13 per cent. water, with small quantities of lime, magnesia, and iron oxide. Clay has been derived from the

disintegration and decomposition of the felspar in granite, gneiss, mica, and slate. Clays are either *residual*, or *transported*. The former, of which china clay or kaolin is an example, are found overlying the rocks from which they have been produced. Transported clays have been deposited under water in beds at the bottom of seas, lakes, or estuaries. All ordinary brick clays belong to this class. The most important property of clay is its plasticity, which is due to the water combined with the silicate of alumina. Some portion of this water is held by absorption in the pores of the clay, and may be driven off on heating to 212° F. The dried clay may still contain as much as 10 per cent. of water in chemical combination, and this can only be expelled at a much higher temperature, say 1100° F., the material completely losing its plasticity, and becoming hard and rigid. Advantage is taken of this property in *brick-making*, the constituents in presence of the flux supplied by the lime being fused into a homogeneous mass during "burning." Fireclay does not contain the materials for forming a flux, and resists fusion on account of the large proportion of silica which it contains, which varies from 65 per cent. in Stourbridge fireclay to as much as 86 per cent. in that from Dinas. *Firebricks* are deficient in strength, but withstand the highest temperatures, and are much used for lining furnaces and ovens. *Glazed bricks* are made from fireclay, and have a thin glaze on the surface, produced by throwing common salt into the kiln during burning. At the high temperature possible with firebrick, the salt is volatilised, and the vapour combines with the silicate of alumina to form glass, which fills up all the pores and covers the surface. A similar process is employed for glazing *stoneware*, which, however, is produced at a temperature sufficiently high to vitrify the mass throughout, rendering it quite impervious even when unglazed. The colour of clay is due to the presence of metallic oxides, chiefly oxide of iron, a small amount of which on burning imparts a yellow colour to the brick. A rather larger proportion produces the ordinary red appearance, and with 8 or 10 per cent. of iron in the clay, burning at an intense heat converts the red into the black oxide, which combines with the silicate to give the dark blue colour characteristic of the very hard and dense *Staffordshire blue bricks* so much used in engineering work. Devonshire clay, being free from iron, is white when burnt, and is

therefore particularly suitable for *pottery*. China clay or kaolin (so called from a mountain of that name in China), which abounds in Cornwall and Devon, is the purest form of clay, having the largest proportion of alumina in its composition, but ordinary potter's clay contains a variety of impurities. To prevent excessive shrinkage and cracking during burning, clay for stoneware is mixed with a certain proportion of sand, ground flint being incorporated with potter's clay for the same reason. Almost all clays require some preparation for brick-making. Thus both silica and lime must be added to the purer or strongly plastic clays, whilst the loamy or sandy clays require lime only, and the marls or calcareous clays may sometimes be used without any addition. *Clay puddle* is largely used in engineering work for the purpose of rendering a structure watertight, as for instance, in lining canals and the embankments of reservoirs. Even in their natural condition such clays as those of London and Oxford are practically impervious to water. Most clays, however, may be utilised for puddle by "tempering," or working up the clay with water so as to fill every pore. It is upon this power of retaining water that the ability of puddle to exclude water depends.

Slate is a metamorphic rock, *i.e.*, one originally deposited as a fine muddy sediment, and subsequently changed or metamorphosed by heat and pressure. Common slate is an argillaceous or clay-like rock, very compact and fine grained. It does not readily part along the original bed, but may be split quite easily along "planes of cleavage" which have been caused by intense lateral pressure long after the rock was consolidated. Slate is hard and tough, and should not absorb water to any appreciable extent. Hence its value as a roof covering, as in addition it can be obtained very thin and light. There are quarries of enormous extent at Penrhyn and Llanberis, near Bangor in North Wales, the slates from which are either blue or red in colour. Slates from Cumberland and Westmorland are remarkable for their beautiful green colour and great durability, whilst those from Delabole in Cornwall are dark grey. The variation in colour is due to the proportion of iron contained. Slate slabs from 1 to 3 inches thick, and from 6 to 8 feet long, are also produced, and are largely used for many purposes connected with engineering and mechanical work. They may be used "self-

faced" as split from the blocks, or may be sawn to shape or planed in a machine similar to a metal planing machine. They may therefore be fitted with great accuracy, and are in considerable demand for cisterns, vats, baths, sinks, troughs, shelves, billiard tables, mantelpieces, flooring, sanitary fittings, etc. Enamelled slate is produced by first painting the surface and drying at about 300° F. in an oven. The enamel is then applied, re-stoved, and afterwards rubbed down, the operation being repeated several times, after which the slate is polished with rotten stone and varnished. Slate has been largely used by electrical engineers for switchboards on account of its high insulation qualities. Slate blocks of considerable size can also be obtained, and are sometimes substituted for masonry where transverse strength is required. The strength of slate 1 inch thick is stated to be equal to that of stone 5 inches thick, and as its resistance to shear is also much higher than stone, slate dowels or joggles are much used for the joints of heavy masonry.

Sandstone is composed of grains of quartz or sand cemented together by silica, or by carbonate of lime or chalk, with which may also be present carbonate of magnesia, alumina, and iron oxide. Sandstones are thus divided into two main classes, siliceous and calcareous, according to the nature of the cementing material. The grains of quartz are practically indestructible, and therefore the durability of the stone depends upon the cementing medium. When this is of a siliceous nature the stone is more durable than when the grains are held together with a calcareous (chalk-like), or an argillaceous (clay-like) substance. If the stone contains much carbonate of lime it is rapidly acted upon by the carbonic acid of the atmosphere, and the grains being loosened, the stone crumbles away. The sulphurous and other acids in the smoke of large towns, although most destructive to limestone, have little effect on the siliceous variety of sandstone, which is exceedingly durable, especially when free from oxide of iron. To the latter substance the colour of the stone is generally due. Commercially, sandstone is classified under several heads: (1) *Thick-bedded*, or *freestone*, which is the best and most homogeneous rock, capable of being broken almost equally well against as with the bedding; (2) *flagstones*, which have a good natural cleavage, caused by plates of mica in the beds, and which split readily in the

direction of the bedding, forming flags of almost any size and thickness; (3) *tilestones*, which are thin-bedded flags, sometimes used for roofing in place of slates; (4) *grits*, which are close-grained, strong, and hard sandstones from the "Millstone grit" formation. Having a high resistance to crushing and wear, they are much used for engine and machine beds, foundations, sea walls, etc., where blocks of large size are required. A hard, compact stone quarried at Kenton, Burton, and other places in the neighbourhood of Newcastle-on-Tyne, is much used for *grindstones*. A special fire-resisting variety, known as *firestone*, is in high repute for the floors of glass furnaces, etc., for boiler flues, and also for hearths. It is a soft calcareous sandstone quarried at Godstone in Surrey, and at Wideopen, near Newcastle, and is obtainable in slabs up to 10 inches thick. The most important deposits of sandstone occur in the carboniferous series adjoining the coal measures, as at Leeds, Bradford, Halifax, Huddersfield, Morley and Wakefield in Yorkshire, at Newcastle-on-Tyne, in Mid-Scotland near Edinburgh, in the Forest of Dean, etc. The many varieties of Yorkshire sandstone, all of which are strong, and wear and weather well, are known under the general term of *Yorkstone*, or "Hard York." *Craigleith*, a whitish grey calcareous sandstone quarried near Edinburgh, is said to be the most durable sandstone, combining the hardness of granite with the beauty of freestone, but the best beds are now almost worked out. *Mansfield* stone, from Nottinghamshire, occurs in two varieties, red and white, the former being considered the most durable. It can be obtained in large blocks, and is suitable for carving and the finest work. A remarkably strong and hard Irish sandstone, known as "Shamrock," from county Clare, is now extensively used.

Limestone.—Several varieties of limestone, such as chalk, marble, Portland stone, etc., are composed of nearly pure carbonate of lime (CaCO_3). Others contain a considerable proportion of carbonate of magnesia (MgCO_3), and are then known as dolomites, or magnesian limestones. Limestones in which a large proportion of clay is present are termed marls. Limestone is either of chemical, or organic origin, in the first case being formed by precipitation, and in the second from the remains of animals. Carbonate of lime is readily attacked by carbonic acid in the presence of moisture, and is rapidly decomposed by sul-

phuric and other acids. Hence, as a rule, limestone is not so durable as sandstone, being liable to attack from the acid fumes in the atmosphere of large towns. Limestone differs greatly in hardness and texture from soft chalk to hard, dense marble. For mechanical purposes, five varieties may be distinguished, viz.: (1) compact; (2) granular; (3) shelly; (4) magnesian; and (5) marble. *Compact limestone*, such as Kentish rag, has a dull earthy appearance, and is devoid of crystalline structure. Lias limestone, used for making hydraulic lime, also belongs to this class. The chief uses are, however, for road metal, and as a flux for blast furnaces and foundry cupolas, also in bleaching, tanning, and other industries. *Granular or oolitic (egg-like) limestone* consists of grains of carbonate of lime cemented together by the same substance. The grains vary greatly in size, from very fine and uniform, as in Chilmark, to the large egg-shaped grains of Bath stone. This class includes many of the best known and most important building stones of this country. Portland stone, which consists of a mass of fossils cemented together by carbonate of lime, is very tough and strong, and as it resists the action of water in a remarkable manner, it has been much used for docks, sea-walls, breakwaters, fortifications, etc. Caen stone, imported from Normandy, is invaluable for interior carving, but weathers badly. *Shelly limestone* consists almost entirely of small shells cemented together. Purbeck stone, sometimes called marble, and the carboniferous limestones from Hopton Wood in Derbyshire, and Pateley Bridge in Yorkshire, are examples of this class, and are largely used for paving. *Magnesian limestone or dolomite*, which is an anhydrous carbonate of lime and magnesia, $(CaMg) \cdot 2CO_2$, contains from 15 to 40 per cent. carbonate of magnesia. It is a soft, easily worked stone, of yellowish colour, and is fairly durable, except when exposed to a sulphurous atmosphere. The principal quarries are at Anston, Huddlestone, and Roche Abbey, in Yorkshire; at Bolsover, in Derbyshire; and at Mansfield, in Nottinghamshire. An important and extensive use of dolomite is for the production of the basic lining of the Thomas-Gilchrist steel converter. *Marble* is, strictly speaking, a hard compact limestone, capable of taking a high polish. True marble is practically pure carbonate of lime, $CaCO_2$, but the name is now understood to include stones such as serpentine, alabaster, and dolomite, which have an entirely different composition. Marble is extensively used

Table of Properties of Stone.

	Weight per cubic foot in lbs.	Crushing Strength. Tons per square foot.	Absorption per cent. of dry weight.
Granites :			
Peterhead	166	1,200	0.29
Corennie	163	1,320	0.42
Rubislaw (Aberdeen)	164	1,290	0.09
Cornish	162	1,060	0.12
Mount Sorrel (Leicestershire)	164	830	0.31
Norwegian	168	1,180	0.26
Slates :			
Welsh	172	1,200	0.50
Sandstones :			
Craigleith	146	560	3.60
Scotgate Ash	160	700	3.40
Lightcliffe	150	820	2.30
Elland Edge	153	710	3.30
Idle, Bradford } Yorkshire	166	725	3.40
Morley	160	470	5.00
Robin Hood	144	590	4.00
Darley Dale	148	650	3.4
Mansfield (Red)	143	590	4.60
Forest of Dean (Blue)	149	530	2.70
Shamrock (Irish)	186	2,200	1.84
Limestones :			
Ancaster	156	550	16
Bath	130	120	17
Kentish Rag	166	470	1.50
Portland	135	280	13
Purbeck	170	590	15
Hopton Wood	158	540	16
Magnesian Limestones :			
Anston	144	300	7.50
Bolsover	152	480	—
Mansfield (Yellow)	146	575	4.62
Roche Abbey	139	250	17
Marbles :			
White Italian	168	1,400	trace
Pentelikon	169	1,100	trace only

as a decorative material, as it may be obtained in almost any colour and with a great variety of beautiful markings. The colour is derived from the presence of metallic oxides, and in "madrepore" marble the "figure" is due to embedded fossiliferous remains. The crushing strength of marble is very high, and the percentage of water absorbed is only slight. The handsome varieties are too expensive to admit of their use for any but ornamental purposes, but the commoner kinds make excellent paving for floors, and the rougher material is used as a flux, etc., for chemical purposes, or is burnt for lime. Marble finds an extensive application in electrical engineering for switchboard work. The presence of veins due to metallic substances is objectionable, and preference is therefore given to the softer and whiter varieties. Formerly, most of the white marble came from Italy and Greece, but of late years a less valuable material, only slightly veined, has been largely imported from Norway in the form of slabs, suitable for counter tops, switchboards, etc. The polishing process is performed by machinery, sand being first used, then pumice stone, followed by rotten stone, and finally putty powder.

Lime, or quicklime, is oxide of calcium, CaO , in a more or less pure state. It is obtained by burning or "calcining" limestone, chalk, or marble, in a suitable kiln, a red heat continued for a few hours sufficing to drive off the whole of the carbonic acid gas, thus:—



The operation is continuous, broken limestone and fuel being thrown in at the top of the kiln, and the lime raked out at intervals from below. Quicklime possesses caustic properties in a high degree, rapidly destroying any organic matter with which it comes in contact. It is therefore of great value in agriculture, and is much used for disinfecting purposes. It "slakes," or combines with water with great violence, giving out much heat, and falling into a soft white powder, which is hydrate of lime, or as it is termed, "slaked lime," thus:—

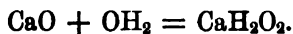

Hydrate of lime dissolves in water, forming a solution known as "lime-water," which rapidly absorbs carbonic acid from the air, and is converted back again into carbonate:—

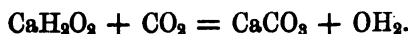

The "setting" of lime depends on the absorption of CO_2 by the calcium hydrate, crystals of carbonate being formed which readily adhere to any rough surface. The use of mortar in building operations, and of plaster for covering the surface of walls, depends upon this action during setting. Limes are classified as follows: (1) Pure, rich, or "fat" limes, which contain less than 6 per cent. of total impurities. Fat lime increases enormously in bulk when slaked, but sets slowly, and is deficient in strength, being used only for plastering and whitewashing. (2) Poor or lean limes, which contain from 15 to 30 per cent. useless impurities. They slake slowly, with little increase in bulk, and have all the defects of fat lime in addition. (3) Hydraulic limes are produced from limestones such as those from the Lias formation (hence termed lias limes), containing a mixture of clay, which constituent confers the property of hydraulicity. They slake with difficulty, but will set firm under water as well as in air, and are most useful in damp situations. *Mortar* is composed of lime and sand, usually in the proportion of 2 or 3 to 1. The sand is added to promote setting, and to prevent excessive shrinkage which would occur with pure lime.

Portland Cement—so called because when set it bears some resemblance to Portland stone—is an artificial product prepared by calcining and grinding a mixture of clay and chalk. A liquid mud or "slurry," obtained by grinding together in edge runners or pug mills chalk and clay in the proportion of 3 to 1, is passed into a large circular tank, in which it is kept moving by revolving beaters to effect a thorough mixture. It is next pumped into the upper end of a rotary kiln, about 7 feet diameter and 60 or 70 feet long, which is lined with firebrick, and set in an inclined position on rollers, so that it may be revolved by power at any required speed. A jet of gas and air, or of fine coal dust and air, is blown in at the bottom of the kiln, producing an intensely hot flame, with a temperature of 2500°F . in the region of the lower end. The products of combustion, cooled down considerably in traversing the length of the kiln, pass out to the chimney at the upper end. In this way, water is evaporated from the slurry by gentle heat in the upper part, the resulting "slip" being thoroughly dried on reaching the middle of the kiln, and subsequently burnt to "clinker" at the lower end. The semi-fused clinker is delivered to a second, and finally to a third, revolving

cylinder, through which cold air is blown, and when cool, it is finally converted into cement by grinding to an extremely fine powder in a ball mill. Fineness of grinding is now regarded as of great importance, and the finer the cement, the greater the strength developed. A cement of good quality will leave not more than 20 per cent. residue on passing through a sieve of 180 holes per linear inch, *i.e.*, of 32,400 meshes per square inch. On adding water, cement has the property of setting and becoming extremely hard, either in air or under water, and as a binding material, it is capable of adhering to, and uniting together with considerable force, substances with which it comes in contact.

Concrete may be defined as artificial stone made by mixing cement as the matrix, with an aggregate composed of sand, crushed granite, broken stone or brick, etc., water in proper quantity being added during thorough mixing, preferably in a machine. The nature and proportions of the aggregate depend upon the purpose for which the concrete is intended. For medium quality concrete, suitable for foundations, walls, arches, ordinary floors, stairs, etc., the proportions should be 1 cement to $2\frac{1}{2}$ of sand, and 5 of aggregate. Concrete is strong in compression, but extremely weak in tension. Concrete with steel in the form of rods or wires embedded in it is known as *re-inforced concrete*, the steel being intended to take tensile stress, and compensate for the deficiency of concrete in this respect. Very extensive use is now made of re-inforced concrete for foundations, walls, floors, roofs, and buildings, and for bridges, piers, and engineering structures.

Asphalte is a natural product, which is mined in the island of Sicily, at Val de Travers in Switzerland, and Seyssel in France, at Limmer near Hanover in Germany, and in Trinidad and Venezuela. It consists of limestone impregnated with mineral bitumen, its composition being 80 to 90 per cent. carbonate of lime, with 10 to 20 per cent. bitumen. The latter substance, which is frequently mistaken for gas tar or petroleum refuse, is a natural mineral pitch, consisting of 85 per cent. carbon, 12 per cent. hydrogen, and 3 per cent. oxygen. It has probably been forced into the rock in a state of vapour under enormous pressure. Asphalte is employed in two forms, *viz.*, powder and mastic. The former is obtained by heating the pulverised rock at a temperature slightly above the boiling point of water. This drives off moisture, and partly liquefies the bitumen, which thus

acts as a binder to the powdery mass when compressed by the blows of the rammers used in laying the material. Asphalte mastic is prepared by heating finely powdered bituminous rock with about 10 per cent of refined bitumen in a mixing machine. After heating to 400° F., the mixture is run into moulds, forming blocks of about 56 lbs. weight. Asphalte makes excellent roadways, and being impervious to water, is used for damp-proof courses laid in the walls of buildings, for covering roofs, vaults, and arches, and for lining tanks and reservoirs.

ABRASIVE MATERIALS.

Emery consists of an intimate mixture of corundum (oxide of alumina) and magnetite (oxide of iron), which is found in nature in North America, Spain, Asia Minor, the islands of the Greek Archipelago, etc. Corundum occurs in transparent form as the sapphire, translucent as commercial corundum, and in a black, opaque mass as emery. On account of its great hardness, emery is universally employed for grinding and polishing, and may be had in the form of powder (flour or grain emery), as emery paper or emery cloth, and in the form of solid discs, wheels, or bars of various shapes and sizes. In the manufacture of wheels, the rock emery as imported is finely pulverised and mixed with some glutinous binding material. For the so-called "tanite" wheel, 75 parts glue are steeped in water and melted by gentle heat, 25 parts tannin dissolved in methyl alcohol being added, and 600 parts of the finely ground emery stirred in and thoroughly incorporated. The mass so obtained is subjected to pressure in moulds previously heated to 220° F., and then raised to, and maintained at, about 255° F. for some time. Both emery and corundum have been used in this way for many years, but both these substances are found to vary very much in quality, and the supply shows signs of diminishing.

Artificial Substitutes for Emery have lately come into extensive use, the chief of which are *carborundum* and *alundum*. The former is a carbide of silicon (SiC), containing 68 per cent. silicon, 30 per cent. carbon, and the rest lime, alumina and oxide of iron. It is produced by fusing together in an electric furnace at a temperature of about 4000° F. a mixture of sand, coke, sawdust and salt. The Carborundum Co. has erected a large works at Niagara Falls, operating with current furnished by the

hydraulic power plants of Niagara. The general arrangement of the furnace is shown in section, Fig. 99, and in the photograph, Fig. 100, and in the photograph,

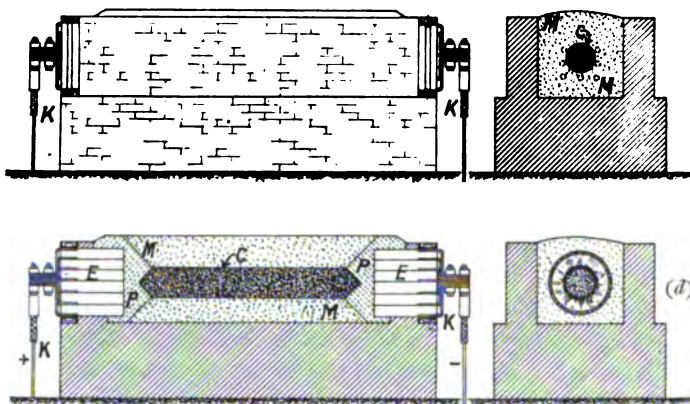

FIG. 99.—Electric Furnace for Manufacture of Carborundum.

Fig. 100. The end walls, of highly refractory brickwork, support the carbon electrodes, E, which, to the number of about



FIG. 100.—Electric Furnace for Manufacture of Carborundum.

twenty-five, take the form of square bars grouped together. Between the separate bars are fixed plates of copper, to which the

cables, K, carrying the electric current are connected. The mixture of sand, coke, sawdust and salt is seen at M. The latter substance is introduced to remove impurities, such as iron, the resulting chlorides being driven off by volatilisation at the high temperature. A core of carbon, C, broken up into small pieces, is arranged in the centre of the mass, and is brought into thorough contact with the electrodes by embedding the latter in powdered charcoal at P. The furnace carries a current of 2,000 electrical horse-power, which is run for thirty-six hours. The arc produced between the electrodes causes the silica (SiO_2), contained in the sand to unite with the carbon, thus:—

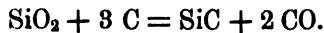

A section of the furnace at the close of the operation is shown at (d), Fig. 99, in which will be seen the carbon core surrounded by a layer of graphite, with the crystalline carbide of silicon (carborundum), and the so-called "white mass" of amorphous carbide of silicon on the outside, M being the portion of the mixture remaining unaffected. *Crystolon* is the name given by the Norton Co., the well-known American makers of grinding wheels, to a carbide of silicon product of their manufacture, which closely resembles carborundum in its properties and method of preparation. In Germany, the same substance is known by the names of carbosilite and electrorubin. Crystolon, being extremely hard and brittle, is highly efficient for grinding and polishing materials of low tensile strength, such as cast iron (ordinary or chilled), brass, bronze, marble, granite, pearl, etc. *Alundum* is manufactured by the Norton Co., of Worcester, Mass., U.S.A., who have a large electric furnace plant at Niagara Falls for the purpose. It is a crystalline form of oxide of alumina (Al_2O_3), prepared from bauxite. Its chemical composition is the same as that of the ruby, which is the hardest natural substance next to the diamond. It is regarded as specially suitable for grinding material of high tensile strength, particularly steel of all kinds. Norton alundum wheels have proved of great value in precision and tool grinding in engineering workshops.

Characteristics of Grinding Wheels.—Abrasive wheels are used for an immense variety of purposes, to meet which a wide range of different qualities, shapes, and sizes is required.

There are two distinguishing characteristics, viz., fineness and

Hardness of Abrasive Substances.

Substance.	How formed.	Specific Gravity.	Hardness on Mohs' scale.	
Diamond	natural	3.5	10	} Will Cut Glass
Carbide of Silicon	} artificial	3.12	9.5	
Carborundum				
Alundum	} artificial	3.9 to 4.3	9.25	
Electrite				
Diamantine				
Corundum	} natural	3.9 to 4.3	9	} Will Scratch Glass
Sapphire				
Ruby				
Topaz	} natural	2.8 to 3.5	8	
Emerald				
Emery (Naxos)	} natural	3.9 to 4.3	8	
„ (Asia Minor)				
„ (Asia Minor)		3.9 to 4.3	7.5	
Quartz	} natural	2.6	7	
Flint				
Agate				
An ordinary File	—	—	6.5	
Common Window Glass	—	—	5.5	

hardness, either or both of which admit of variation in adapting the wheel to the class of work to be done. The *fineness*, or size of the grains of the grinding material, is expressed by the number of meshes per square inch of the sieve through which they will pass, and this number is referred to as the "grit" or *grain* of the wheel. Thus, No. 30 is a grain which will pass through a sieve of thirty meshes to the square inch but will be retained on a sieve of thirty-six meshes, which is the next standard size, as shown at page 199. Emery and carborundum are crushed into grains numbered from 6 to 220, 6 being the coarsest, and 220 the finest manufactured. It is, however, not practicable or necessary to use the very coarsest or finest numbers in making wheels, and

experience has shown that the following numbers meet all ordinary requirements:—

Emery . . . 16, 20, 30, 36, 46, 60, 70, 80, 90, 100, 120, and 150.
 Carborundum 14, 16, 20, 24, 30, 36, 40, 50, 60, 70, 80, 90, 100, 120.
 Alundum . . . 14, 16, 20, 24, 30, 36, 46, 50, 60, 70, 80, 90, 100, 120.

Two considerations govern the selection of the proper grit for any piece of work, viz., the smoothness of finish required, and the amount of material to be removed in a given time.

The *Smoothness of Surface* produced by emery of different degrees of fineness may be compared to that left by files, as follows:—

8 to 10	produce a surface similar to that left by a rasp for wood.
16 „ 20	„ „ a rough file.
24 „ 30	„ „ middle cut file.
36 „ 40	„ „ bastard „
46 „ 60	„ „ second cut „
70 „ 80	„ „ smooth „
90 „ 100	„ „ superfine „
120 F, and FF	„ „ dead-smooth „

Hardness, as applied to grinding wheels, is understood to refer to the quality of resistance to disintegration. To form a wheel, the sharp, angular particles of the abrasive, or “grit,” must be embedded in some binding material, or “bond,” for cementing them together. After the particles have become dulled by the act of grinding, they must be allowed to break away in order to keep the wheel sharp. The longer the particles are retained, the duller they become, and the greater the pressure required to make the wheel cut. The hold, or grip of the bond upon the grits, is accepted as equivalent to hardness, and the term *grade* refers to the degree of resistance to the breaking out of the particles possessed by the wheel. Different grades are obtained by varying the nature of the binding material used to hold the grains together.

The various processes of manufacture are distinguished chiefly by the substance employed to cement the grains together. The essential feature of the “bond” is that it shall wear away about as fast as the grains themselves, so as not to remain projecting beyond the true surface of the wheel when the grains are detached, nor to combine with the cuttings of the material

operated upon to form a glaze. At the same time, it must not be affected by water, or by the heat produced by grinding, and it must be sufficiently strong to withstand the centrifugal force due to the high speed at which the wheel must be run. The various cementing materials in more or less successful use are: (1) common glue hardened with tannin, as in the "tanite" wheel; (2) vulcanite, or hard rubber; (3) asphaltum; (4) celluloid; (5) shellac; and (6) silicate (*i.e.*, a mixture of silicate of soda and chloride of calcium).

It must be admitted that wheels produced by either of the first five processes (known as *composition wheels*) are liable to the defect of gumming or glazing, as the bond takes little or no part in the operation of grinding. A more scientific and efficient process is to employ a cementing substance which may be fused or burnt during manufacture, and which therefore possesses some value as an abrasive. *Vitrified wheels* produced in this way are porous, and easily penetrated by water without being injuriously affected. As all grinding should, whenever possible, be performed wet, this is a very valuable property. For grinding chilled iron or hardened steel rolls, or for finely finished and highly polished surfaces, the quality of elasticity is indispensable, and it has been found that this is best attained with wheels made by the shellac process, and therefore known as *elastic wheels*.

Carborundum and alundum wheels are produced by three different processes known as vitrified, silicate, and elastic. The vitrified wheel has proved superior for most grinding operations, and the majority of wheels are now made in that way. The grit is mixed with bonding clay of the proper consistency, is run into moulds, and when sufficiently dry to handle, the wheels are placed in a kiln and subjected to the temperature at which the bond vitrifies, for a period of from six to twenty days, depending on the size. In the silicate process the bond and grain are mixed, and while in a plastic state are tamped into iron moulds, and baked at a low temperature. For tool and knife sharpening, silicate wheels answer well, and the process is generally adopted for wheels of large size. Elastic wheels made by the shellac process are especially useful where highly-polished surfaces are required, or for operations in which wheels with thin sharp edges are necessary.

A wheel from which the particles are easily detached is called soft, and for emery, corundum, and alundum wheels the grade from soft to hard is denoted by letters, A being extremely soft, M medium grade, and Z extremely hard, as shown in the table below. The Carborundum Co. have, however, adopted the reverse nomenclature, a practice which, it is to be feared, has led to no little confusion.

Grade Scale for Degree of Hardness of Grinding Wheels.

Emery and Corundum.	Alundum and Crystolon.	Grade.	Carborundum.
Extremely Soft	A	
		B	
		C	
		D	Very Hard
Soft	Soft	E	
		F	
		G	G ×
			Hard
			H ×
		H	
			I ×
Medium Soft	Medium Soft	I	Medium Hard
		J	
		K	
		L	
Medium	Medium	M	Medium
		N	
		O	
		P	Medium Soft
Medium Hard	Medium Hard	Q	
		R	
		S	
		T	Soft
Hard	Hard	U	
		V	
		W	Very Soft
		X	
Extremely Hard	Extremely Hard	Y	
		Z	Very Very Soft

The intermediate letters are referred to as degrees harder or softer ; thus L is one degree softer than medium, and O is two

Table of Grades and Fineness of Grinding Wheels for Various Purposes.

Kind of Work.	Emery and Corundum.		Carborundum.		Alundum.		Crystolon.	
	Grain.	Grade.	Grain.	Grade.	Grain.	Grade.	Grain.	Grade.
Brass Castings	30	N	24-36	H to I	—	—	24-36	P to R
Bronze Castings	20	P	20-30	H to I	—	—	24-36	P to R
Cast Iron (roughing)	—	—	16-24	F to H	—	—	—	—
Cast Iron (finishing)	—	—	60-80	G + to H	—	—	—	—
Cast Iron (cylindrical)	—	—	24-60	L to N	24	J to K	30-46	J to L
Cast Iron (chilled)	16	Q	20-24	H + to H	20-30	P to U	20-30	Q
Cast Malleable Iron	20	P	16-24	G + to I +	20-30	P to R	20-33	Q to S
Drop Forgings	30	P	20-36	F + to G +	20-30	P to R	—	—
Lathe and Planer Tools	36	O	24-36	H + to I	20-36	O to P	—	—
Milling Cutters, Reamers, etc.	60	K	50-80	J to O	46-60	H to M	—	—
Saws (sharpening, etc.)	36-46	M	365	K to M	36-50	M to N	—	—
Steel Castings	16	Q	16-20	G + to H	20-30	P to R	—	—
Twist Drills	46	K	40-50	M to O	36-60	K to M	—	—
Wrought Iron	16	Q	16-24	E to H	12-30	P to U	—	—
Steel (soft) cylindrical	—	—	—	—	46-60	L to N	—	—
Steel (hard) cylindrical	—	—	—	—	46-60	J to L	—	—
Steel (soft) surface	—	—	24-36	H to J	24-36	H to K	—	—
Steel (hard) surface	—	—	—	—	36-46	H to K	—	—

degrees harder than medium on the emery scale. It is found that grades M, N, O, P, Q, and R afford a sufficient range for general engineering and foundry purposes, as shown in the table, p. 202.

Selection of Proper Grain and Grade.—The proper degree of coarseness and hardness can only be determined by trial. As a general rule, a hard wheel acts slowly, and tends to become “glazed,” or clogged with particles of the material being ground. On the other hand, a soft wheel cuts rapidly, the particles being abraded, and a fresh surface of the wheel exposed. The speed at which the wheel is run is a matter of great importance. If too high, the wheel will glaze and the work become heated, and if run too slowly, the wheel wears away rapidly, doing little work. The best results are obtained with a peripheral speed of not less than 4,000 and not more than 6,000 feet per minute, and this would appear to vary very little whichever kind of abrasive is employed.

Hones and Oilstones used in setting the edges of cutting tools belong to the class of sandstones. The name oilstone is derived from the fact that oil must be used to float off the fine particles of steel removed from the tool in sharpening, in order to prevent filling up the minute pores of the stone. The oil must not be allowed to coagulate upon the surface of the stone, or it will considerably diminish, if not altogether destroy, the cutting action. This is due to the small, sharp-pointed grains or crystals of silica, which are hexagonal in form, and being harder than steel, will cut away and sharpen hardened steel tools. A number of varieties of natural oilstone have been put upon the market, differing widely in abrading power or rapidity of cutting, and as a general rule it may be stated that “fast cutting” is almost synonymous with “coarseness of edge” produced. An oilstone must be of uniform texture and of even grain throughout, as, unless it wears quite evenly, it cannot produce a smooth, unscored edge. Thin veins of quartz are sometimes present, which are harder than the stone itself, and therefore wear away less rapidly, with the result that the cutting edge of the tool may be badly scored. The chief varieties of oilstone in use are as follows: (1) *Washita*, found at Hot Springs, Arkansas, U.S.A. This stone resembles carved marble in appearance, but is really a hard compact white sandstone, being composed of nearly pure

silica. The best stone is very porous, of uniform texture and perfect crystallisation. The poorer grades are vitreous, or "glassy," rendering the stone almost worthless. For joiners' and woodworkers' tools, in which quick cutting rather than fineness of edge is the chief desideratum, Washita is much in request. (2) *Turkey Stone* is quarried in Asia Minor, and is a very fine close-grained stone, containing about 75 per cent. of silica, intimately blended with about 25 per cent. calcite. The colour ranges from white to very dark grey, and may be of several shades in one and the same piece. It possesses exceptional abrading qualities, and will cut the hardest steel with very little pressure, but is incapable of imparting a very fine edge. It is very variable in quality, and although expensive, is difficult to obtain of serviceable size without seams or flaws. (3) *Charnley Forest Stone*, found near Mount Sorrel, in Leicestershire, is dark grey or greenish in colour, with red markings, and is much less costly than Washita or Turkey. It is of medium cutting quality, but gives a tolerably fine edge, and answers well for woodworking tools. (4) *Arkansas* is composed of pure silica, and is found in the same district as Washita, which it resembles, but is more compact, of much finer grain, harder and more transparent. It is much the best stone for sharpening very fine edge-tools, such as those used by engravers, surgical instruments, etc., and it will both cut and polish the hardest metals. The rock is difficult to quarry, being badly cracked and streaked with quartz, so that only a very small proportion of pure, sound stone can be obtained, and that of comparatively small size. Arkansas is consequently very costly, or at least four times more so than Turkey. (5) *Belgian Hone* is largely used for fine cutlery, razors, etc. It is a fine soft-gritted stone, capable of imparting a keen, lasting edge. It is full of coloured veins or spots, which distinguish it from other varieties, but do not in any way affect its sharpening qualities. (6) *German Hone* consists of a thin "rubber" of very soft yellow-green stone cemented upon a thin layer of somewhat harder stone of a dark blue colour. Its use is limited to setting razors, to which it readily gives the smooth, "gummy" edge so much desired. (7) *Scotch Hone, or Water-of-Ayr Stone*, is used with water instead of oil, and must be kept constantly wet to preserve its good qualities. It is used to some extent by carpenters, tool-makers, instrument makers

and opticians, but largely for polishing marble, lithographic stones, etc. (8) *Chocolate Stone*, and one or two other similar varieties of fine gritted sandstone, quarried in Indiana, U.S.A., may be used dry, or with either oil or water, with equally good results. They are much softer than Washita, and wear away much faster, but leave a fairly fine edge. (9) *Artificial Oilstones*, such as India Stone, which is made from corundum, and those produced by the Carborundum Company, are specially suitable and convenient for engineers' use, the grit and grade being adapted for sharpening lathe and planer tools, milling cutters, drills, reamers, etc., or for any other purpose.

ASBESTOS, from the Greek signifying "incombustible," is a highly fibrous mineral, more nearly resembling silk than stone. It is said to melt at about 2800° F., and its application in the industries is due to its incombustible nature, and to its properties as an insulator of both heat and electricity. As a packing and jointing material, especially for high temperatures, it is almost without a rival, and forms the basis of many well-known preparations. Asbestos is occasionally found as a deposit in some of the oldest rocks which form the earth's surface, such as hornblende or amphibole, augite, mica, chrysolite, and serpentine. Like the rocks which surround it, asbestos is mainly composed of silicate of magnesia SiO_3Mg , together with some lime, alumina and iron. Its colour varies from yellow or brown to green or blue, although some varieties are snowy white. It is usual to classify asbestos either as of amphibole or chrysolite variety, the difference being chiefly in the amount and condition of the water contained. The amphibole variety contains about 5 per cent. of water, all of which is in combination, whereas in chrysolite about 15 per cent. of water is present, of which 3 per cent. is hygroscopic or free. It follows that when heated to 1200° F., the strength and other properties of chrysotolic asbestos are seriously affected, whilst on the other hand, the amphibole variety can withstand a temperature nearly twice as high. Unfortunately, the fibre of amphibole asbestos is invariably so brittle that it cannot be spun or woven, and for commercial purposes this variety is of comparatively little value. Very large and abundant deposits of chrysolite asbestos have been discovered in various parts of the world, the quality being tough, with long silky

texture, and capable of being spun and woven with ease. The present sources of supply are the Italian Alps, Russia, Canada, and South Africa, of which the two latter are by far the most important. The Cape asbestos is long, soft and very flexible, and is of a beautiful blue colour due to the presence of a certain amount of oxide of iron. This is said to render blue asbestos unsuitable for electrical purposes. The asbestos-bearing rock, which is mined in open pits, is first crushed or disintegrated, and then "cobbed" by hammering and screening, and assorted by means of packing belts into three classes: (1) long fibre for spinning and weaving, (2) short fibre for millboard and similar uses, and (3) residue or powder, which is utilised for cement, paint, pipe and boiler coverings, etc. Under each of these heads, the various applications of asbestos are exceedingly numerous. As a fire-resisting material in the form of double boarding for safety curtains in theatres, partition walls, firemen's and electricians' gloves and clothing, lamp wicks, lumps for gas fires, and as a paint for wooden structures, it is very largely used. For jointing steam and water pipes, it is supplied in the form of millboard, or in rings, with rubber, wire gauze or thin sheet metal insertion, to give the necessary strength and durability. In combination with rubber, it is also extensively used for piston and valve rod packing, and also for glands, cocks, etc., a form which, with the increasing use of superheated steam, has almost displaced all others. As a heat-insulating material, it is employed in two forms, either as a "sectional" covering for steam pipes, boilers, etc., or as a cement for large or flat surfaces. In the first case, asbestos fibre mixed with carbonate of magnesia is moulded into half cylinders, which being held together by an outer covering of canvas can be clasped round the pipe, and secured in position by means of flexible steel bands provided with buckles. Asbestos cement is a mixture of residue with infusorial earth (kieselguhr), itself a bad conductor, to which felt refuse is added as a binder. This may be made into a paste by the addition of water, and plastered over the surface to be protected. Asbestos has also proved a valuable material for electrical purposes, being a good insulator and at the same time non-inflammable. Bricks, tiles, slabs, and slates of asbestos for walls, ceilings, partitions, roofs, etc., are now largely used in fireproof building construction. The slates are much lighter than ordinary slates,

and can be sawn, nailed, and painted quite readily. *Uralite* is composed of asbestos fibre cemented together by a mineral glue, and pressed into sheets or slabs of two kinds, hard and soft. The hard variety is intended for external work, partitions, etc., and the soft for insulation, jointing, fire-resisting doors, etc.

GLASS is a silicate of at least two metals of different groups, one of which must be an alkaline metal. The alkaline silicates possess the property when fused at a high temperature of dissolving a considerable quantity of silica. Glass is thus a mixture of various insoluble silicates with excess of silica. Two principal varieties of glass are recognised commercially, viz.: (1) glass composed of silica, alkali, and lime, of which *crown* and *plate glass* are examples, and (2) glass containing a large proportion of lead silicate, as in the case of *flint glass*. It is found that lead increases the fusibility, and renders the glass denser and more lustrous. Common green bottle glass contains a large amount of silicate of iron, to which the colour is due. For colourless glass it is essential that no iron should be present, and plate glass, for instance, must be made of the purest materials. The process of glass manufacture is, in principle, exceedingly simple. Silica in the form of sand is heated with carbonate of potash or soda, and either slaked lime or lead oxide. These ingredients, termed "frit," fuse and combine together at a high temperature, say 2700° F., the melted mass of "metal" becoming perfectly clear and extremely fluid. The melting is effected in large crucibles or "pots" of refractory fireclay, each containing about 22 cwts. About one-third of the whole charge is always composed of broken or waste glass, which is known as "cullet." The molten mass on cooling gradually assumes a soft pasty condition of which advantage is taken by the workman in the operation of "blowing." A lump weighing about 20 lbs. is collected on the end of the blow-pipe, which is an iron tube, 5 or 6 feet long, provided with a wooden mouthpiece. By blowing, the lump is enlarged into a flask-like vessel, the shape of which depends upon the position in which it is held, and the velocity of rotation of the tube, which is kept constantly turning. Glass is classified as *crown*, *sheet*, or *plate*. Crown glass is made in large circular *tables*, the large globular flask produced by blowing being transferred from the blow-pipe to the end of an iron rod, which is rotated with such

rapidity that by centrifugal force the flask presented to the heat of the furnace is made to assume the form of a thin flat disc or "table." This is laid on a support, and after cutting off the rod, is removed to the annealing furnace, and allowed to cool slowly. The "bull's eye" or bullion formed at the point of attachment of the rod is removed on cutting up the disc, the resulting pieces being about 16 inches \times 12 inches. In addition to the limited size, crown glass is not regular in surface or thickness, often showing circular wave-like markings, and very little is now manufactured. In making sheet glass, a globe is first produced by blowing, and is then opened and expanded into a large cylinder. After removal from the rod, the neck portion is cut off, and the cylinder split up longitudinally by a diamond. The cylinder with the split side upwards is placed in the flattening kiln, and on softening by heat, it gradually opens out and falls flat upon the table. As in all processes of glass manufacture, it is finally annealed. The thickness of sheet glass used for window glazing, picture framing, etc., is expressed as the weight in ounces per square foot, the standard thicknesses being 16, 21, 26, 32, 36, and 42 ozs. The actual thickness of 21 ozs. may be taken at $\frac{1}{10}$ inch, and the others in proportion. The stock size for medium thicknesses is about 4 feet \times 3 feet. Plate glass is made by pouring out white-hot glass on a flat cast iron table, a roller of the full width being passed over the surface. When solidification has just taken place, the plate is taken to the annealing furnace, on removal from which it is known as rough cast plate, the material so much used for glazing the roofs of railway stations, etc. The surface is very uneven and the glass lacks transparency, requiring to be ground and polished for the best work, such as shop windows, etc. It is then described as polished plate, and can be obtained in any thickness from $\frac{3}{16}$ inch up to 1 inch, and in sizes up to 100 feet super for the standard thickness of $\frac{1}{4}$ inch. Different colours may be communicated to glass by certain metallic oxides. Gold, for instance, gives a ruby colour; oxide of cobalt, blue; chromium oxide, emerald green; ferric oxide, orange; uranic oxide, yellow green; tin oxide, opaque white, etc. Opalescent glass for lamp shades, thermometer scales, etc., is made by the addition of sodium fluoride.

Glass tubing is produced by forming a thick hollow bulb

on the end of a rod, when a working rod is attached to the other end, and the two rods drawn apart, extending the bulb into a tube. Gauge glasses for steam boilers, engine fittings, etc., which have to resist internal pressure must be made of specially selected materials, and must, above all, be carefully annealed.

CHAPTER XIX.

OILS, LUBRICANTS, ETC.

FORMERLY oils of vegetable origin, and to some extent, animal oils and fats, were used for lubricating engines and machinery, but these have now been very largely superseded by mineral oils, either alone or mixed with saponified oil or soap to form what is known as a grease or solidified oil. *Vegetable oils* may be divided into two classes, (1) "drying oils" (as, for example, linseed oil), which are subject to "gumming" or rapid oxidation on exposure to the air, and are used only for painting; and (2) "non-drying" oils, of which rape oil is typical, and which on exposure tends sooner or later to become rancid, *i.e.*, to develop organic acids. Oils of the first kind are quite unsuitable for lubricating purposes, and must be avoided. Of the second class, olive, castor, rape, and cotton-seed oils are extensively used. They are extracted by hydraulic pressure from the crushed seed, and afterwards purified by means of a 1 per cent. solution of sulphuric acid, which must be entirely removed by subsequent washing. Of the *animal fats*, tallow has been widely employed for lubricating hemp-packed stuffing boxes, and lard, neatsfoot, and sperm oils have still their special uses. *Mineral oils* are derived mainly from crude petroleum, and in limited quantity from shale. Petroleum is found chiefly in the United States, at Baku in Russia, and in Burmah. The distillation of crude petroleum yields in order petrol or petroleum spirit, benzine, lamp oil, and what is termed petroleum refuse. The latter is a thick viscous substance, from which on further distillation with increasing temperature, the following products come off in the order given:— (1) Solar oil, used largely for lighting purposes; (2) spindle oil, specific gravity $\cdot 89$ to $\cdot 90$; (3) machinery oil, specific gravity $\cdot 90$ to $\cdot 92$; and (4) cylinder oil, specific gravity $\cdot 92$ to $\cdot 925$. As thus obtained, the impure oils are usually dark-coloured, necessitating treatment with sulphuric acid, followed by copious washing, and charcoal filtration. The suitability of an oil for the purpose

in view depends mainly upon (1) its *viscosity* or consistency, and (2) its *unctuosity* or lubricating power. A certain viscosity is necessary to prevent the oil from being squeezed out under pressure, which would permit the surfaces to come into metallic contact, causing abrasion and ultimate seizure. The proper degree of viscosity thus depends upon the intensity of the pressure upon the bearing. But with an increase in viscosity, the internal friction of the lubricant itself also increases, and upon this the value of the coefficient of friction between the two surfaces largely depends. Under the very light load to which the spindles of a spinning frame are subjected, a thin oil, such as spindle oil, will not be forced out. But the internal friction of this thin oil, *i.e.*, its resistance to displacement on the bearing, is also very small, and therefore in this case, a thin oil lubricates better than a thick oil, or grease. Hence for any particular purpose, that oil lubricates best which has just sufficient viscosity to be retained on the bearing, and at the same time possesses the smallest possible degree of internal friction among its own particles. As regards lubricating power, experience has shown beyond doubt that animal oils, such as lard, neatsfoot, and sperm, possess this property in the highest degree, vegetable oils, such as olive, rape, and castor, being decidedly inferior, with mineral oils lowest in the scale. An oil of any one kind alone is, as a rule, much less efficient than a mixture of two or more kinds properly blended for each particular set of conditions. The conditions to be fulfilled are:—(1) The viscosity must be as low as will just enable the load to be carried; (2) the internal friction of the oil itself must be as small as possible; (3) the lubricating power must be as great as possible; and (4) oxidation must be prevented, or reduced as far as possible by the addition of a suitable quantity of mineral oil. The viscosity of any oil is reduced with rise in temperature, and although a lubricant may be quite efficient at ordinary temperatures, it may become so thin as to be of little value when used for steam-heated surfaces. When exposed to temperatures corresponding to high-pressure steam, oils of animal and vegetable origin are speedily decomposed, forming products of an acid character, which rapidly corrode the metallic surfaces with which they come in contact. Mineral oils, on the other hand, may be obtained with sufficient viscosity, and are not affected by superheated steam, or even the high tempera-

tures which are met with in the cylinder of a gas engine. Indeed without mineral oil, recent developments in each of these directions would have been quite impossible. It is therefore of great importance to determine the "flash point" of an oil intended for use at high temperatures. The *flash point* is the temperature at which the vapour given off from the oil may be ignited by a small flame, without actually setting fire to the oil. The "burning point" is the temperature at which the oil itself takes fire and continues in flame. Cylinder oil may be obtained with a flash point of 700° F., and there is now no difficulty whatever in securing a flash point of 480° F. with lubricating qualities of the highest order. Special precautions must be taken in handling oils of very low flash point, 79° F. being fixed by law as the dangerous limit. It is usual also to ascertain the freezing point, as an oil with a high flash point will sometimes become quite stiff and immovable in cold weather. This is of great importance for ice-making machines, refrigerators, etc.

Testing of Lubricants.—Lubricants are tested in several ways for the determination of: (1) Chemical properties, action on metals, etc.; (2) specific gravity; (3) gumming or oxidation; (4) viscosity; (5) smoke, flash, firing, and boiling points; (6) setting or freezing point; and (7) friction and durability, by testing machine. Each of these tests is capable of affording valuable information, although in some respects the interpretation of the results must be left to an expert.

(1) By *chemical analysis* it is possible to ascertain the amount of water, and of free acid or alkali present, and this should never exceed a mere trace. The corrosive action on metals at ordinary and at high temperatures is also determined in the chemical laboratory. Properly refined mineral oils have no effect whatever on metallic surfaces, but if mixed with animal or vegetable oils, the latter may, in the presence of high-pressure steam, be gradually decomposed into fatty acids and glycerine. The chemist is also able to discover any adulteration, such as resin, tar, asphalt, caoutchouc, soap, etc., which may be dissolved in the oil, either accidentally, or with the object of improving the colour, greasy feeling, etc.

(2) The *density or specific gravity* is determined by means of the *hydrometer* or densimeter, which has a graduated glass stem connected to a cylindrical or pear-shaped bulb to give buoyancy,

and beneath which is the "sinker," containing small shot or mercury, to cause the instrument to float in an upright position. When placed in the liquid to be tested, the instrument sinks to a depth which enables the specific gravity to be read off on the graduated stem.

As oils are lighter than water, the graduation representing water will be found at the lower end of the stem, and the instrument will sink to a greater depth the lighter the liquid in which it is placed. The scale may be made to read specific gravity direct, in which case, however, the graduations will not come at equal distances apart, Fig. 101 (a). Empirical scales with uniform graduations are easier to construct, and are found to be more convenient in use, and of these Baumé's has perhaps been most widely adopted, Fig. 101 (b). The zero is obtained by placing the instrument in a solution of 10 parts common salt in 90 parts water, and the scale is arranged so that distilled water = 10°. Having read off "degrees Baumé," the true specific gravity is found by reference to a table.

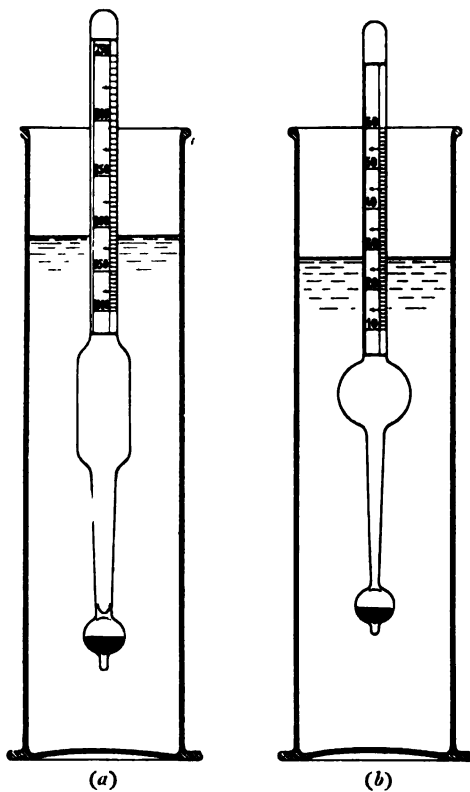

FIG. 101.—Hydrometers.

The table is calculated by means of the formula

$$\text{True specific gravity} = \frac{146.78}{136.78 + n}$$

where n = degrees Baumé.

Beaumé's Hydrometer for Liquids Lighter than Water.

Degrees.	Specific Gravity.	Degrees.	Specific Gravity.	Degrees.	Specific Gravity.	Degrees.	Specific Gravity.	Degrees.	Specific Gravity.
10	1.000	18	0.948	26	0.901	34	0.859	42	0.820
12	0.986	20	0.936	28	0.890	36	0.849	44	0.811
14	0.973	22	0.924	30	0.880	38	0.839	46	0.802
16	0.960	24	0.913	32	0.869	40	0.830	48	0.794

The reading of a hydrometer should be taken at normal temperature, *i.e.*, 60° F., and for any other temperature a correction should be applied.

(3) *Test for Gumming and Oxidation.*—This may be carried out in a simple way by means of Nasmyth's apparatus, Fig. 102,



FIG 102.—Test for Gumming and Oxidation of Oil.

made by Messrs. W. H. Bailey & Co., of Manchester. By inserting the pipette in one of the small holes provided, a drop of known size is allowed to fall upon a zero line at the top of an inclined plane of glass. The glass plate may be kept at standard or any required temperature by means of a heating arrangement inside the box. The time taken is noted, and the distance travelled down the incline is

read off on a graduated scale at the side, and as a very thin film of the oil is exposed to the atmosphere on the plate, the tendency to absorb oxygen and the degree of gumminess is rendered apparent. The results may be plotted on a diagram, Fig. 103, for easy comparison. The test may also be carried out by allowing one drop of the oil under test to fall upon a glass plate about 2 inches \times 4 inches, which is placed in a horizontal position, and heated to a temperature of 120° F. for machinery

oil, or 212° F. in the case of cylinder oil. A very thin film is formed, the condition of which is observed from day to day. It has been found as the result of this test extending over many months that pure mineral oil is absolutely free from any tendency to oxidise. At the same time, considerable evaporation takes place, the lighter mineral oils, such, for example, as machinery oil, disappearing entirely when the thin film is maintained at a temperature of 120° F. for thirty-five hours. Rape oil under

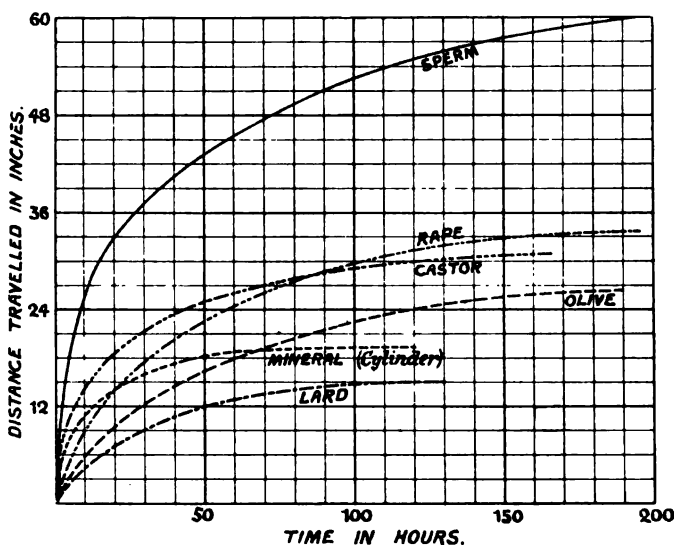

FIG. 103.—Test for Gumming and Oxidation of Oil.

this treatment soon thickens, finally becoming quite dry and hard.

(4) *Test for Viscosity.*—*Redwood's Viscosimeter*, Fig. 104, is now recognised in this country as the standard instrument for the determination of viscosity. The oil receiver, A, which is of copper, silver plated, is 1 $\frac{7}{8}$ inches in diameter, and 3 $\frac{1}{2}$ inches deep. In the bottom is fixed an agate jet, J, having an opening which may be closed by a small ball valve, V, attached to a wire. It is important that the hole through the jet should be of standard size, viz., .067 inches in diameter. The oil receiver is surrounded by a water jacket, C, 5 $\frac{1}{2}$ inches diameter \times 3 $\frac{1}{2}$ inches deep, provided with a diagonally projecting tube, E, for heating the water

to the required temperature. On the outside of the oil receiver is fitted a sleeve carrying four blades, H, which when revolved to and fro serve to agitate the water in the bath. The required temperature of the water, as shown by the thermometer, T, carried on the sleeve, is first attained, and according to the nature of the oil to be tested, is usually either 70° or 120° F. Oil previously

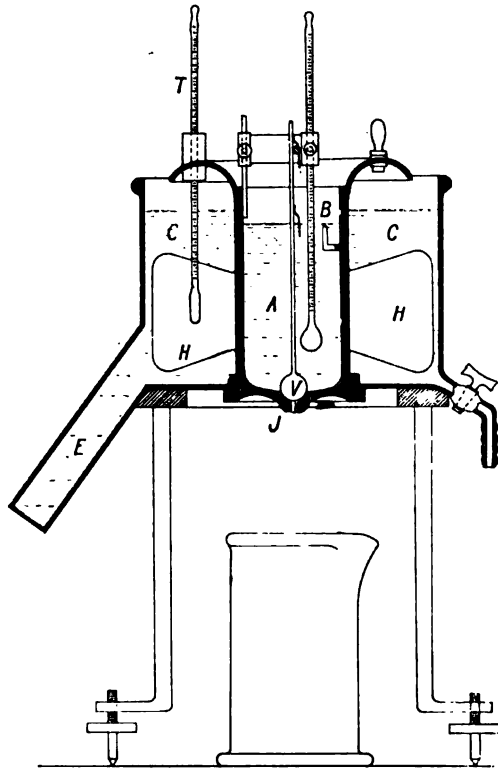

FIG. 104.—Redwood's Viscosimeter.

heated to the same temperature is then poured into the receiver to the level of the upturned point of the hook gauge, B, fixed on the side. A narrow-necked flask, graduated to 50 c.c. on the stem, is placed immediately beneath the jet in a vessel of water maintained at the same temperature as the oil. The ball valve is raised, and simultaneously a stop watch is started, the number of seconds occupied in the discharge of 50 c.c. being noted. It is

desirable that at least two observations should be made at the same temperature. The time in seconds is taken to express the viscosity of the oil, which, if desired, may be reduced to its proper value with any standard of comparison as unity.

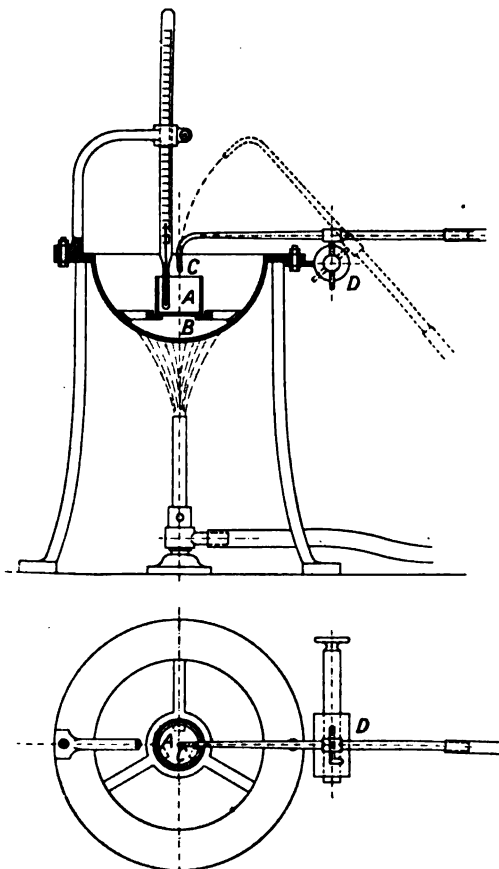

FIG. 105.—“Open” Flash Point Apparatus.

For practical purposes, the viscosity of rape oil at 60° F. is usually adopted as standard. From a number of tests made with his apparatus, Redwood found that 535 seconds may be considered as the average time occupied by the outflow of 50 c.c. of refined rape oil at 60° F., the viscosity of water under similar circumstances being 25.5. Taking rape oil as standard, and

calling its viscosity = 100, the viscosity of any other oil will be found by multiplying the number of seconds occupied by the outflow of 50 c.c. by 100, and dividing by 535. In the case of an oil having a different specific gravity from that of rape oil, which is 0.915 at 60° F., a correction must be made by multiplying the result by the specific gravity of the sample at the temperature of the experiment, and dividing by 915. If T = number of seconds for an oil under examination, and s = its specific gravity,

$$\text{Viscosity} = \frac{T \times 100 \times s}{535 \times 915} = 0.0002042 Ts.$$

What is known as the commercial viscosity of an oil is determined by the following expression :—

$$\text{Viscosity} = 0.205 Ts.$$

(5) *Flash and Firing Points*.—A small quantity of the oil to be tested is placed in an open porcelain crucible, A, which is heated in a sand bath, B, by means of a Bunsen burner, Fig. 105. The temperature is taken from time to time, and occasionally a tiny gas flame, C, is brought to within $\frac{1}{10}$ inch of the surface of the oil for the space of two seconds without actually touching the oil or the edge of the crucible. For this purpose the gas jet is mounted on a swivel, D, working between stops as shown, which enables the flame to be brought into the correct position without trouble. In Gray's form of the apparatus, as made by Messrs. Baird and Tatlock, the crucible or cup is closed by a cover which may be rotated about $\frac{1}{4}$ revolution, thus opening a small port through which, by the same movement, the flame is introduced. When, on introducing the flame, a flash is observed, or a slight explosion takes place, the temperature read off on the thermometer gives the flash point. On still further raising the temperature until the oil, after being ignited, continues to burn, the firing point may be observed.

(6) *Freezing or Setting Point*.—This is not regarded as a test of much importance in this country, although in colder regions it requires attention. It is necessary to fix upon a standard degree of solidification due to the lowering of the temperature, and this is usually taken to be such that a pressure of 2 inches of water will cause the frozen oil to rise $\frac{3}{8}$ inch in a glass tube $\frac{1}{4}$ inch diameter in one minute.

(7) *Mechanical Testing*.—The efficiency of any oil or grease as

a lubricant may be ascertained by noting its behaviour when tested under normal conditions on a standard bearing of known dimensions. A number of *oil-testing machines* have been brought out for this purpose, most of them based upon the principle of the celebrated "pendulum" tester of the late Professor Thurston, which is made in this country by Messrs. W. H. Bailey & Co., Ltd.,

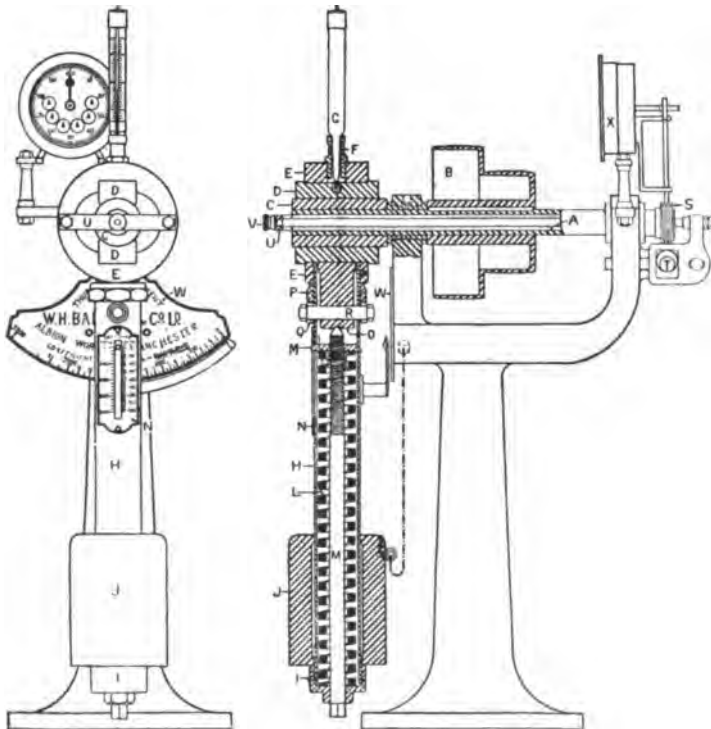

FIG. 106.—Thurston Oil Tester.

of Manchester. As seen in Fig. 106, it consists of a frame forked at the top to form two bearings for a short shaft, A, on which is fixed the driving pulley, B. The machine is most conveniently driven by a small electric motor, in such a manner that any desired speed may be obtained. The shaft is continued to form an overhung journal, C, which is embraced by two half-brasses, D, contained in a frame, E, fixed to the pendulum, H. The coefficient of friction of an oil varies with the temperature, and it is

important that the temperature should be maintained constant throughout a test. A thermometer, G, is therefore mounted in the bearing so that the temperature may be noted at intervals. The pendulum is tubular, and inside it is placed a spring, L, by means of which pressure may be put upon the journal. On the pendulum there is a graduated scale, N, showing on one side the total pressure on the bearing, and on the other side the load per

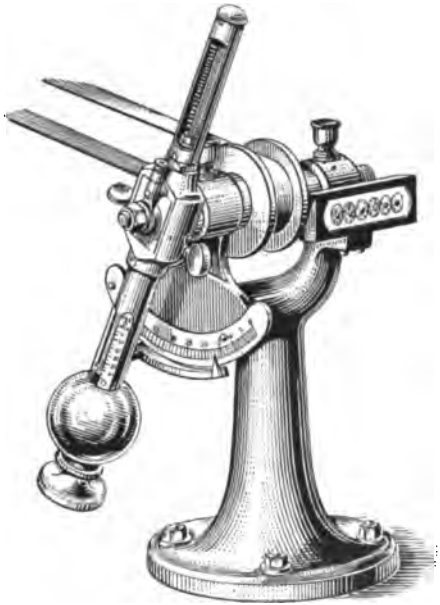

FIG. 107.—Thurston Oil Tester in Use.

square inch, and the pressure may be adjusted by means of a screw which is turned by the milled head at the bottom of the pendulum. In this way the test may be made to extend over a series of bearing pressures, the results being plotted in the form of a curve. The pendulum carries a "bob" weight, J, at its lower end to provide the necessary moment for opposing the resistance due to friction. When the shaft is rotated the pendulum swings through a certain angle from the vertical, Fig. 107, and by means of a pointer moving over a graduated arc, W, a reading is taken from which the value of the coefficient of friction may be determined.

Let P = total pressure, and p = pressure per square inch on the journal, of which r = radius, and l = length respectively; T = pressure of the spring; W = weight of pendulum and bob; R = effective length of pendulum; θ = angle of deviation of the pendulum from the vertical; F = force required to overcome friction; and μ = coefficient of friction. The total load is applied to both brasses, and as weight of pendulum may be neglected so far as pressure on bearing is concerned, $P = 2T$, and therefore

$$p = \frac{P}{2(2r)l} = \frac{2T}{4rl}$$

But $\mu = \frac{F}{P}$, and as moment of F = moment of weight of pendulum and bob

$$Fr = P\mu r = \mu 2Tr = WR \sin \theta,$$

$$\text{and } \mu = \frac{F}{P} = \frac{WR \sin \theta}{Pr}.$$



FIG. 108.—Self-recording Oil Tester.

The quantity $\frac{WR \sin \theta}{r}$ is shown on the graduated arc, and thus it only remains to divide the reading on the arc by the reading on the pendulum to obtain the required coefficient. When making the experiment, the oil to be tested is fed continuously on to the bearing, and the machine is run until the reading of the thermometer becomes constant. The displacement of the pendulum may then be read off. The coefficient of friction increases rapidly just after starting, but after awhile falls off again, and it is only after running for some time that normal conditions are reached. The machine may be made self-recording, as seen in Fig. 108, and an example of the diagram produced is given in Fig. 109, which exhibits the peculiarity just referred to.

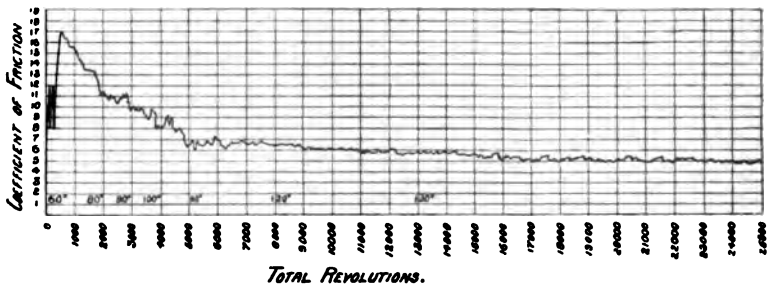

FIG. 109.—Diagram from Self-recording Oil Tester.

Such tests, to be of real value, must always be reduced to some standard of comparison, and it is only in the proper interpretation of the results that their safe application lies.

The *lubricants used for various purposes* may be classified as follows:—

- (1) Extremely heavy pressures: Graphite or plumbago, talc, and mica.
- (2) Heavy pressure and slow speed: Tallow, solid grease.
- (3) Heavy pressure and moderate speed: Lard oil, thick mineral oil.
- (4) Moderate pressure and speed: Olive, neatsfoot.
- (5) Light pressure and high speed: Sperm, light mineral oil.
- (6) Steam cylinders and valves: Heavy mineral oils.

Mineral Oil for Lubricating Purposes.— It is usual to specify that an oil suitable for lubricating steam engines and for similar

high-class uses shall have a specific gravity of from 0.9 to 0.92 at a temperature of 70° F. The flash point must not be under 320° F., and the viscosity at 70° F. should be 600, falling off at 120° F. to 120. The oil must be free from water, acid, wax, tar, or fatty matter, and must be entirely soluble in benzine of specific gravity 0.67 to 0.7. No change whatever must be apparent after twenty-four hours' exposure to the air in the form of a thin film, and the evaporation at 350° F. for two hours must not exceed 0.5 per cent. The heavy dark "cylinder" and "valve" oils for use in the cylinders of engines working at high pressure, and with superheated steam, have a viscosity of from 500 to 700 at 120° F., and the flash point is exceptionally high.

Physical Properties of Lubricating Oils.

Name.	Specific Gravity at 60° F.	Viscosity in secs. for 50 c.c., by Redwood Viscometer.			Viscosity, Sperm Oil at 70° F. = 100.			Flash Point, F.°	
		Temperature F.			Temperature F.				
		70°	120°	212°	70°	120°	212°		
Vegetable. { Non-drying. Semi-drying. Drying.	Olive (dark green)915	270	95	45	213	75	58	435
	Castor (pure cold-pressed)	.966	5,160	670	92	2,500	390	70	485
	Palm923	—	—	—	—	—	—	—
	Cottonseed (refined)	.923	260	100	50	190	69	43	520
	Rape, or Colza915	405	147	54	250	88	50	480
	Linseed (raw)932	255	107	46	—	—	—	540
	Hempseed926	—	—	—	—	—	—	—
	Neatsfoot Oil915	366	126	48	247	82	—	460
	Lard Oil915	295	116	52	223	79	—	495
	Engine Tallow947	Solid	53	—	—	—	—	510
Animal Oils and Fats.	Lard934	—	—	—	—	—	—	—
	Sperm878	126	65	36	100	45	35	460
	Whale922	—	—	—	187	71	48	475
	Seal925	—	—	—	137	59	45	—
Fish Oils.	Petrol (Petroleum Spirit).	.700	—	—	—	—	—	—	50
	Petroleum814	35	30	27	—	—	—	—
	Watch Oil	—	—	—	—	—	—	—	—
Mineral Oils.	Light Machinery Oil893	464	105	45	—	—	—	—
	Heavy Machinery Oil899	1,020	210	52	—	—	—	—
	Gas Engine Oil884	520	140	45	—	—	—	—
	Cylinder Oil891	6,120	472	95	—	—	—	—

CHAPTER XX.

LEATHER, INDIARUBBER, GUTTA PERCHA, ETC.

THE skins of all the domestic, and of many wild animals, are cured or tanned for the purpose of making leather. Those from the larger animals are known as hides, and from the smaller

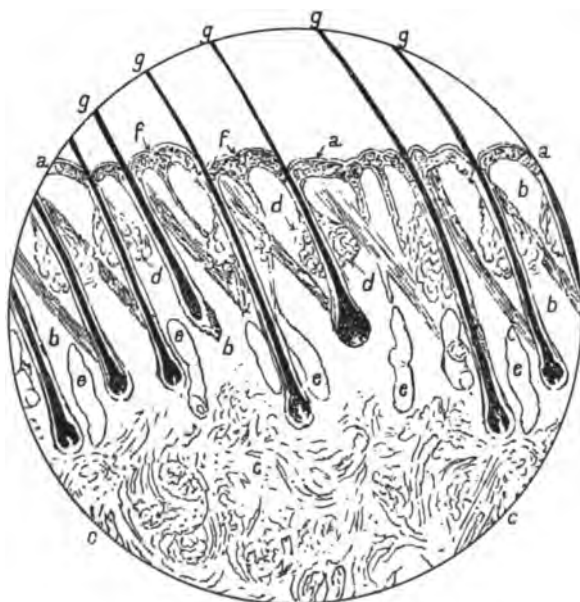

FIG. 110.—Section of Ox Hide ($\times 40$).

animals as skins. Fig. 110 represents a section of an ox hide, magnified about forty diameters, which shows that the skin consists of three layers: (1) the outer skin or epidermis, *a*, (2) the leathery skin or corium, *b*, and (3) the inner layer or dermis, *c*. The epidermis contains no blood vessels, and consists solely of a mass of horny scales, packed closely together. This portion is removed preparatory to the tanning process. The

M.T.

Q

leathery skin is made up of cells, which are soft and round, and which at the top are constantly being dried and pressed flat into scales to form the epidermis, which is always being renewed. The dermis is composed of a fibrous substance, or tissue, and is full of blood vessels and capillaries. It also contains the sweat glands, *e*, from which minute tubes or ducts run right through the epidermis to the pores, *f*, on the outer surface. This part is also removed before tanning proper commences. The hair, *g*, grows from minute sacs or bulbs in the leathery skin, passing through ducts in the epidermis. In the production of leather, the hair is taken off preparatory to tanning. The business of the tanner and currier is thus found to comprise three distinct branches: (1) preparatory processes, (2) tanning proper, and (3) finishing. In the first place, the hides are thoroughly soaked in a vat of clean cold water, and all dirt washed out. They are then laid over a beam, and the surplus fat removed with a blunt fleshing knife. They are next placed in a vat of weak lime, and are lifted out daily, the lime being strengthened until the hair gets loose, which takes about a week. After thorough washing in water they are laid upon a beam, and the hair taken off with a blunt knife. All traces of lime remaining are next removed by repeated washing, when the hides are ready for the "handlers." These are large vats containing tannin liquor, which is very weak at first, and is gradually strengthened. In this the hides are hung for ten or twelve days side by side on sticks very close together, and just below the top of the vat. This treatment is intended to open the pores and "plump up" or swell the hide, to give thickness and firmness to the leather. The *tanning process* proper now commences, the operation being effected by means of certain vegetable, mineral, or animal matters, according to which it may be described as (1) bark tanning, (2) chemical tanning or "tawing," as in the production of white and chrome leathers, and (3) chamois dressing, as in the manufacture of glove kid, wash-leather, etc. In the bark process, the active agent is tannic acid, obtained by "leaching" or steeping the rind or bark of the oak in water. The hides are packed in large vats called "lay-aways," each capable of containing about six dozen. The hides are carefully deposited one on the top of the other, with a layer of ground bark between, and when the vat is full, strong tannin liquor is run in until all are completely covered. According to

Mr. C. A. Schieren, the well-known belting manufacturer of New York, the hides should be taken out after ten days, and the bark renewed six times, the time allowed being increased about five days for each succeeding layer, so that the last layer will require about forty days to penetrate the leather. In this way good leather may be tanned within four months, although for belting and other prime uses, six months should be allowed. For the production of white leather, a solution of alum and common salt is employed, which, however, remains soluble and may be removed by washing, the leather becoming hard and brittle after drying. Good results have recently been obtained by the use of chrome salts, and the operation occupies much less time than bark tanning. Chamois dressing is effected by rubbing into the skin to be cured fatty matter such as train oil, which is then allowed to oxidise by exposing the skin to the air. The grain or hair side is purposely removed during the preparatory treatment to render the leather soft and supple, and capable of being washed without losing its good qualities. The *finishing processes* to which leather is subjected depend largely upon the purpose for which it is intended. If required of close and hard quality, it is hammered or rolled, but if, on the other hand, softness and pliability are the chief desiderata, the leather is treated with oil or tallow before drying. Several distinct qualities of leather are put upon the market, the chief of which are: (1) *Sole leather*, which is extremely dense and hard, and is used principally for boot and shoe purposes. It is tanned from thick ox or buffalo hides, a considerable time in strong liquor being allowed. It is finished by hammering and rolling, and does not undergo any treatment with oil or grease. (2) *Belt and prime harness leather*, which is slowly tanned from selected hides in moderately strong liquor. When the leather is taken from the vat, it is oiled on the grain side and hung up in a darkened room to dry at a uniform temperature, very little heat being used. It should then be of a clear russet colour, and if required for belting, the hide is soaked in warm water, and the "prime" or "butt" portion cut out, Fig. 111. The rest of the hide is known as waste or "offal," and is finished and rolled for bootmaking. After thorough cleansing, the butt is oiled on the grain side and hung up to dry, and in a semi-dry condition it is dressed with "stuffing," composed of beef tallow and train oil in equal parts.

This requires about twenty-four hours to penetrate the leather, which is then kept under considerable strain for some time in special stretching machines. It is finally worked down smooth and hard by machinery, and is put into a drying room to season.

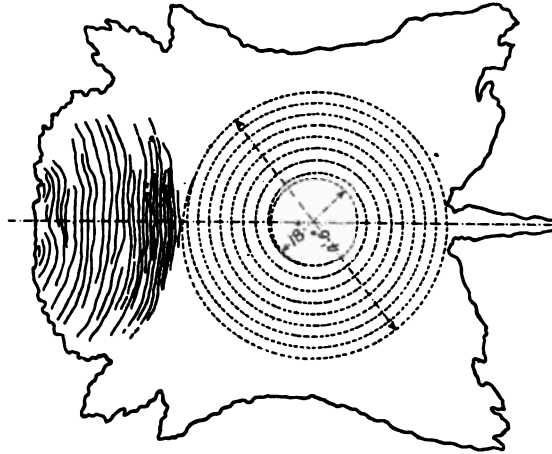

FIG. 112.—Sampson's Method of Belt-making.

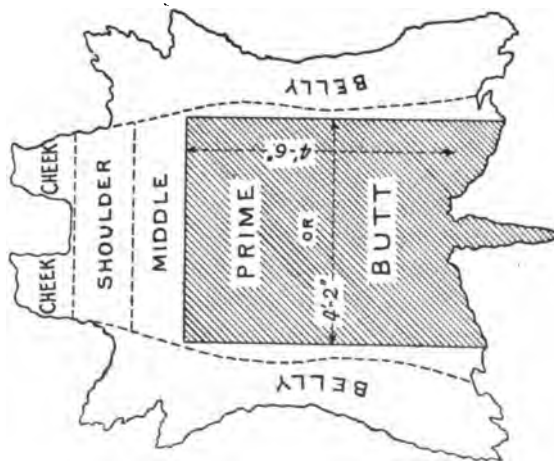

FIG. 111.—Prime or Butt of Hide for Belt-making.

The ordinary *method of belt-making* is to cut the leather into strips of the width required, the pieces being accurately matched for thickness, and then joined together to form a belt of any required length. The joints are made by “feathering” or paring down the ends of the strips in a special machine, and over-

lapping and cementing them with glue, the joint being kept under hydraulic pressure until set. In the case of wider belts, the joints may also be sewn with waxed thread, laced with thongs, or wire rivetted or clenched, as an additional precaution. Messrs. Sampson & Co., of Stroud, have adopted the method shown in Fig. 112 for making a long belt without transverse joint. Starting from a circle about 18 inches diameter, the leather is cut in spiral form, the strip thus obtained measuring $1\frac{1}{2}$ inches wide, and sometimes as much as 150 feet long,

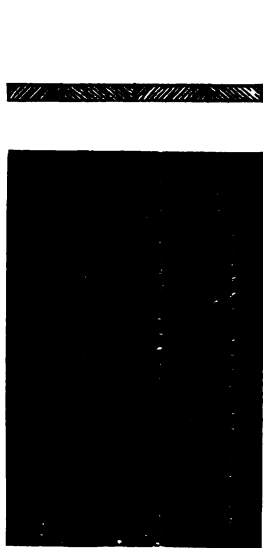

FIG. 113.—Single Belt on Sampson's System.

Wire Clenched Double Leather Belt

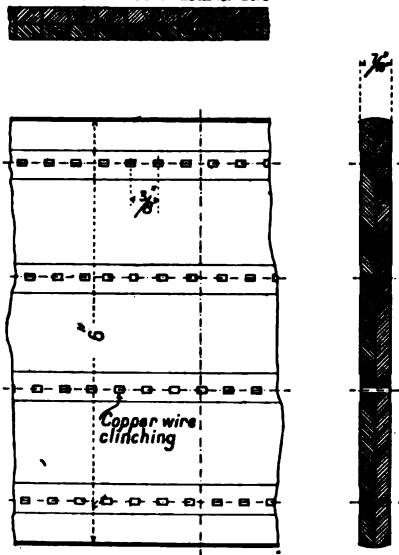

FIG. 114.—Double Leather Belt.

necessitating for all ordinary belts the making of one transverse joint only. The spiral of leather is stretched and pressed by special machinery until completely straightened out, and all unevenness is found to disappear. Two such strips (Fig. 113) are sewn together to make a $2\frac{1}{2}$ inch belt, having a seam running up the middle, which it is claimed, enables the belt to adapt itself to the shape of the pulley, and obtain a better grip. *Double Belting.*—When a belt of single thickness would be of inconvenient width, a double belt is used, made by cementing two strips together, and then sewing or clenched with one rivet to

every 3 or 4 square inches of belt, Fig. 114. In the case of double belts made from leather cut spirally on Sampson & Co.'s plan, Fig. 115, the single belts are put with the longitudinal seams face to face, a thickness of canvas is inserted, and then the whole is pegged through with wood pegs, the outer edges being sewn with waxed thread. Many large belts up to 6 or 8 feet wide have been constructed on this plan. There is one width more on the pulley side than on the outside of the belt, the joints being arranged to "split" or break. From prime leather are also made the *hydraulic leathers or packings* used for presses and other hydraulic machinery.

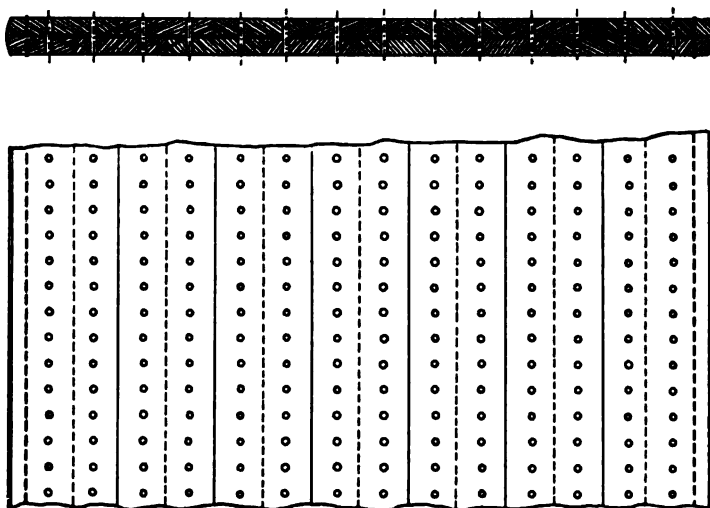

FIG. 115.—Double Belt on Sampson's System.

Such packings are made from solid discs of leather, which are "blocked" when in a moist soft condition in moulds of the required form, in a hydraulic press, Fig. 116. After forming to shape by means of punch and die, the bottom, in case of hat and U leathers, is punched out by means of a ring, as shown. The mould containing the leather is then set in a warm place, and left to dry for a few hours, when the projecting portions are cut away, and the edges bevelled, as shown. A simple form of clamped mould, which may be made of hard wood, and which answers well for the smaller sizes, is shown in Fig. 117. Air holes must be provided in the moulds to allow air to escape, or the

mould cannot be closed properly. (8) *Upper Leather*, so called from its application in the manufacture of boot uppers. It is tanned from thin hides, such as those of the cow, horse, calf, and

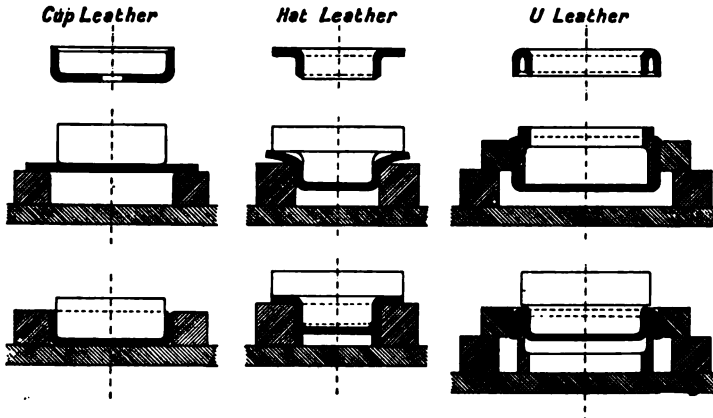

FIG. 116.—Method of Blocking Hydraulic Leathers.

goat, the process being accomplished with weak liquor and in relatively short time. During the finishing operation, it is dressed with carrier's dubbin, consisting of train oil and tallow, of which cowhide may absorb as much as 50 or 60 per cent. (4) *White*

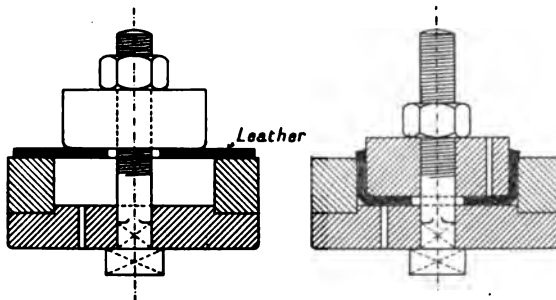

FIG. 117.—Block for forming U Leathers.

Leather is produced largely from the skins of sheep and lambs, its principal use being for the manufacture of kid gloves, and for linings. It is softened, not by dressing with oil or grease, but by drawing it repeatedly over a smooth rounded surface of iron. (5) *Washleather* and *Buckskin*, etc., are obtained from the skins of

the chamois, deer, and goat, and have a wide application in the production of fancy articles. (6) *Raw Hide*. To ensure noiseless running of toothed gearing at a high speed, pinions made of raw hide are frequently employed. This material is produced from salted buffalo hides in the form of thin discs, which are reduced to a solid mass in an hydraulic press, and may then be turned or machined exactly in the same way as cast iron, to which it is scarcely inferior in strength. Pickers for operating the shuttles of power looms are almost invariably made of raw hide, which is

also employed for the manufacture of driving bands both of round and wedge-shaped section, the latter being extensively used for motor cycles. Laces or thongs of raw hide are much used in making the joints of leather belts.

Substitutes for Leather Belting. —

Woven belting, manufactured from cotton, flax or "hair," is the most formidable rival of leather. There are two principal varieties, (1) *Canvas Belting*, in which a stout canvas, or white cotton "duck" of the necessary strength, is folded to the required width and thickness, and passed between rollers, which press the "plies" together. It then proceeds to a sewing machine, which has a set of rollers on each side, the function of one set being to advance the canvas, that of the other to hold it back. The canvas is thus powerfully stretched, in

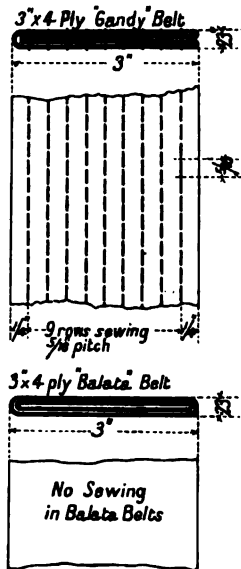

FIG. 118.—Woven Belting.

which state it is sewn, the rows of stitching being about $\frac{5}{16}$ inch apart, Fig. 118. It is next allowed to soak in a large tank of linseed oil for about a fortnight, after which it is removed to a second tank containing red silicate paint. The surplus oil is afterwards squeezed out in a mangling machine, when the belt is ready for the final process of imparting "stretchlessness" by straining it in large frames for about a fortnight. The well-known "Gandy" belt is the best example of this class, Fig. 118. (2) *Cotton Belting*. Commercially, the difference between "cotton" and "canvas" belting is that cotton

is woven in one solid web, whilst canvas is folded to the required breadth and thickness. Otherwise the material and process of manufacture is the same for both. The so-called "camel-hair" belting, which has the appearance of rough Turkish cloth or fibre matting, is not camel hair at all, but is woven from coarse Egyptian cotton, and subsequently coated with red silicate paint, as above described. The paint is intended to act as a preservative, to protect the cotton from atmospheric influences and the attack of moths and insects. Other substances, such as creosote (used in the "Scandinavia" belt), have from time to time been proposed with the same object. *Indiarubber Belting.* A cotton foundation may also be waterproofed by cementing together the canvas plies with a composition of indiarubber. This gives good results in damp situations, but is expensive, and must be kept free from oil or grease. *Balata Belting,* prepared in a similar manner with balata (see p. 236), is quite impervious to moisture, and has given the greatest satisfaction for driving in the open air, or in the steam-laden atmosphere of dyehouses, etc., and for conveyors.

Most textile or fibre belts are stronger and lighter, and less expensive than leather. They can be obtained of any reasonable length without joint, perfectly straight, and of uniform breadth and thickness, and therefore capable of running with great regularity and evenness. They are better adapted for use in hot damp climates, or for exposure to heat and steam, than leather. On the other hand, no really satisfactory method of making the joint in a woven belt has yet been devised. With the best of fasteners at present in use, the strength of the joint does not exceed 30 per cent. of the strength of the solid belt. Except in situations for which leather is not adapted, manufactured belts are found to wear badly when compared with leather, and are quite unable to resist the action of belt forks or guides, as required for fast and loose pulleys, etc.

Indiarubber or Caoutchouc is the congealed and dried juice or milk of various trees growing in tropical countries, and is essentially a mixture of several hydrocarbons of the turpentine oil series. The best quality, known as Para rubber, which comes from Brazil, is obtained from several of the *Hevea* species, and constitutes the most important source of supply at the present time. The raw rubber is more or less dark-coloured, partially

transparent in thin slices, but opaque in the lump. The most noteworthy property of rubber is its elasticity, but it is also very plastic, or capable of being moulded. The tapping, collecting, and smoking of the milk is done by natives. From a spiral incision made in the bark of the rubber tree, the latex or milk is allowed to flow into cups, as seen in the photo, Fig. 119, kindly



FIG. 119.—Tapping the Indiarubber Tree.

supplied by Messrs. David Bridge & Co., Ltd., Castleton, the well-known makers of rubber machinery. Solidification of the juice is effected in several ways. On the banks of the Amazon in Brazil, the end of a club-shaped stick is covered with clay, and is thrust into the juice, when a thick covering adheres, and is caused to congeal by holding the stick over a smoky fire. The operation is repeated until a sufficiently thick coating of rubber is obtained, which is then cut through on one side, and drawn off the stick. The juice of the Para tree contains about 32 per cent. caoutchouc, 12 per cent. albuminous and saline matters, and 56 per cent.

water. The process of *dissolving indiarubber* was patented by MacIntosh in 1823, coal tar oil being used for the purpose. Ordinary rubber is made up of two constituents, one soft or viscous, and easily removed by solvents, and the other hard and fibrous, capable of being worked up when allowed to swell in coal tar oil. Native rubber is hard when cold, but becomes soft and sticky on being heated. It is therefore unsuitable for the

majority of purposes, especially as in this form, it also absorbs water to the extent of 25 per cent. of its own weight. Rubber is therefore vulcanised or melted with sulphur, a process discovered by Goodyear in 1842. In this form it retains all its original properties, or if anything is even more elastic than unvulcanised. Its nature may however be entirely changed by the operation of "burning," *i.e.* exposure to a temperature of from 250° to 265° F. If the amount of sulphur is increased to 25 per cent. of the weight of the rubber, and the mixture strongly heated for a sufficient length of time, the substance known as *Ebonite* results. Raw rubber is readily penetrated, and swells considerably when immersed in either benzine or carbon bisulphide, but when vulcanised is little acted upon. Many applications of rubber, such as the manufacture of shoes, etc., depend upon its plasticity, and the fact that it can be moulded into any shape before vulcanising. For this purpose, the raw rubber is cut into small pieces, is boiled in water, and is washed by passing through rollers over which a stream of water is kept constantly running, to remove dirt and impurities. It is then mixed with flowers of sulphur, and thoroughly masticated in a kneading machine. The heat generated, which may be assisted from an outside source if necessary, renders the mass perfectly plastic, so that it may be moulded into any required shape, or rolled out between heated rollers into thin sheets. After the desired form has been imparted to them, the objects are subjected to the burning process, which is often effected by the action of steam in large receivers. Rubber exposed to the air and also to strong light, deteriorates rapidly. It is also partially dissolved by oil or grease, a very minute trace of which causes oxidation and cracking. It dissolves in pure ether and petroleum, and remains unchanged on the evaporation of the solvent. It is softened, but not dissolved, by boiling water, and is insoluble in alcohol. Pure caoutchouc has a specific gravity of 0.925, and consists of carbon 88½ per cent., hydrogen 8½ per cent., and oxygen 3 per cent. Indiarubber, although expensive, is in great request as one of the best known materials for the insulating covering of electrical cables and conductors. Large quantities of rubber are consumed in the manufacture of pneumatic tyres for motor-cars, and of flexible tubing, hose pipe, etc., for gas and water.

Gutta Percha, discovered in 1843, resembles indiarubber in some respects, although not to be confounded with it. Gutta

percha is derived from the coagulated milk-juice of certain trees of the *sapotaceæ* order, growing chiefly in Malacca, Sumatra, and Borneo. The collection and preparation of gutta percha is carried out much in the same way as in the case of indiarubber, with the difference that the tree must first be felled before bleeding for the juice or "gutta." Gutta percha may be vulcanised in the same way as indiarubber, and with similar results. Unlike rubber, however, gutta percha is not elastic. In the raw state, it is brownish in colour, but when pure is quite white. It may be entirely dissolved in carbon bisulphide, or chloroform. Being an excellent insulator of electricity, and at the same time quite insoluble in and impervious to water, it is much used for covering submarine telegraph and other cables.

Balata is not, as commonly supposed, a vegetable fibre, but a gummy substance resembling gutta percha. It is obtained from the milky juice of trees of another variety of the *sapotaceæ* order, which flourish abundantly in British Guiana. Exposure to light and air does not affect balata to the same extent as rubber and gutta percha. It is much used for waterproofing purposes, and in the manufacture of woven belting.

PART II.

PREPARATORY PROCESSES.

CHAPTER XXI.

CLASSIFICATION OF METHODS OF WORKING.

COMMENCING with the raw material, as already shown, the operations involved in fashioning metals into various shapes may be classified as follows:—

(A) Methods depending upon the property of fusibility, by pouring or “casting” the molten metal into a mould of the required form.

(B) Methods depending upon the properties of malleability and ductility, such as hammering or “forging,” rolling, wire-drawing, etc.

(C) Methods depending upon the property of divisibility, or cutting, such as “turning” or “machining,” shearing, punching, grinding, etc.

The first two methods of working may be regarded as preparatory, and in the majority of cases are followed to a greater or less extent by operations comprised under the third head.

SECTION A.—METHODS DEPENDING UPON THE PROPERTY OF FUSIBILITY.

For the production of castings, the metal is melted in crucibles, or in a special type of furnace called a cupola, and is poured into moulds formed in sand contained in suitable boxes. The mould is usually formed by means of a wooden pattern, which is made of the same size and shape as the required casting. Consequently, three distinct branches of work must be recognised, viz., *pattern-making*, *moulding*, and *founding*, the latter referring more particularly to the melting and pouring of the metal. Certain general principles which are of great importance alike to the designer and the pattern-maker, must first be considered. Almost all substances expand when heated and

contract when cooled, but in the case of metals, it is desirable to distinguish between liquid and solid contraction. The former refers to the gradual lessening in volume of the fluid metal as it approaches solidification, and the latter to the contraction after solidification has taken place until the metal is cold. This is best expressed by referring to "liquid shrinkage," and "solid contraction." As a result, the casting is appreciably smaller than the hollow interior of the mould in which it was formed, and to compensate for this, the pattern-maker must "allow for contraction," by making the dimensions of the pattern larger than those of the required casting, by an amount equal to the shrinkage and contraction which take place during solidification and subsequent cooling. The coefficients of expansion for different metals are well known, and bear some relation to the contraction which occurs in cooling down from the melting (*i.e.* solidification) point, and which is usually taken as follows:—

	Per foot.
Cast iron in bedplates, frames of large machine tools)	} $\frac{1}{10}$ in.
" " " girders, lathe beds, etc.)	
" " " pipes and cylinders)	
Brass	$\frac{1}{20}$ "
Gun metal	$\frac{1}{8}$ "
Steel	$\frac{3}{16}$ "
Copper	$\frac{3}{16}$ "

The average amount for cast iron may be taken at $\frac{1}{10}$ inch per foot, which is equal to $\frac{1}{4}$ inch in 2 feet 6 inches, and so-called "contraction rules," longer than the ordinary 2 feet rule in this proportion, may be had in the shops, and answer well for general work. At the same time, it should be noted that the contraction of a complicated casting, such as a steam engine cylinder, does not follow any regular rule, and although a heavy casting will usually contract less in proportion than a light one, spur wheels, on the other hand, contract in diameter proportionately much less for small than for large sizes. The quality of the metal must also be taken into account, as hard iron of the mottled or white variety contracts more than grey. In fixing the allowance for contraction, much must therefore be left to judgment and experience in all but very ordinary cases. The effects of contraction, and especially of unequal contraction in cooling, may, unless carefully guarded against, produce unsound places, warping, twisting, or even fracture

of a casting, and must be thoroughly understood by the draughtsman and designer. A casting cannot possibly cool simultaneously in all parts. The outside sets and contracts first, and to this the still liquid metal inside attaches itself as it solidifies, leaving a

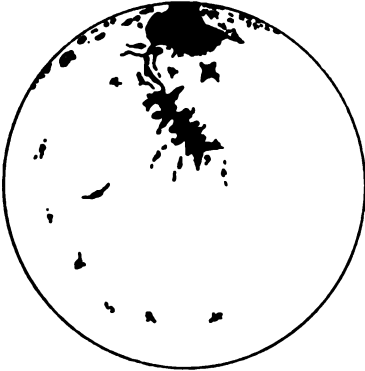

FIG. 120.—Casting for Solid Ball.

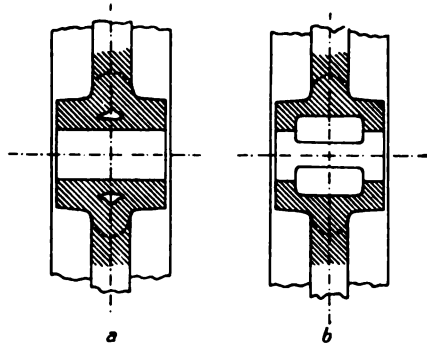

FIG. 121.—Junction of Arms and Boss of Wheel or Pulley.

porous or hollow place in the interior. Hence, on breaking a casting intended for a solid ball, Fig. 120, a cavity will be found extending from above the centre upwards, and similarly, near the junction of the arms and boss of a wheel or pulley, Fig. 121, a "drawn"

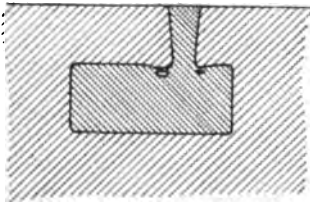

FIG. 122.—Junction of Gate or Runner.

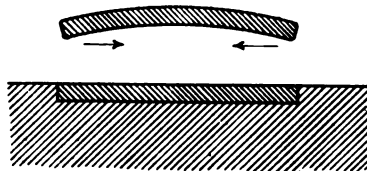

FIG. 123.—Plate Cast in Open Sand.

place will often be observed. The junction of a gate or runner with the thick part of a casting will produce the same result, Fig. 122, a rough surface or depression being left on the outside, with a hollow cavity immediately beneath. Due to the vacuum in this cavity, the metal above is forced in during cooling by atmospheric pressure, thus leaving the characteristic depression generally noticed. The position of the casting in the mould will

also influence the rate of cooling. In the case of a *plate cast in open sand*, Fig. 123, the upper surface, being directly exposed to the air, cools rapidly and sets, while the lower portion in contact with the sand of the mould parts with its heat much more slowly, and continuing to contract after the upper part has set, causes the plate to become "rounded" on the top. Again, the heat can get away much more rapidly from the outside than from the inside of a *hollow cylinder*, and consequently the outside cools and sets first, and is thrown into compression by the contraction of the interior which is still cooling, as shown in the cross section, Fig. 124. It is thus seen that unequal contraction is bound to produce a state of internal stress, which, acting in opposition to the strength of the material, seriously reduces the load which

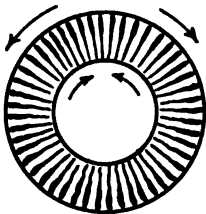

FIG. 124.—Contraction of Hollow Cylinder.

may be safely put upon the casting, or may even produce fracture before removal from the mould. A familiar case is that of a *wheel or pulley*. If the section of the rim is large in proportion to the arms and boss, as in a small fly wheel, the rim will cool last, and by contracting upon the arms, which thus act like radial pillars, may be broken, as in Fig. 125. On the other hand, the rim of a handwheel or pulley, being com-

paratively thin, will set before the heavier arms and boss, the subsequent contraction of which will put the arms in tension, rendering them liable to fracture at their junction with the rim, Fig. 126. For this reason, the arms of small fly wheels and pulleys are often made curved, Fig. 127, a form which, on account of its elasticity, readily permits of a slight alteration in length in either direction, thus avoiding stresses of dangerous magnitude. From these considerations, a very important rule is deduced, viz., that *the thickness of a casting should be kept as uniform as possible, and that wherever inequalities in thickness are unavoidable, the change in section should be as gradual as possible*. Formerly great importance was attached to the determination of the most economical form of section for a cast iron girder, which, in order to allow for the great difference in the compressive and tensile strengths of the metal, was supposed to require a thin and narrow top flange united to a thick and wide bottom flange, Fig. 128 a.

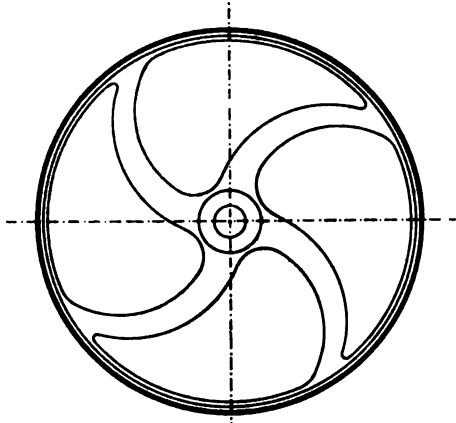

FIG. 127.
Pulley with Curved Arms.

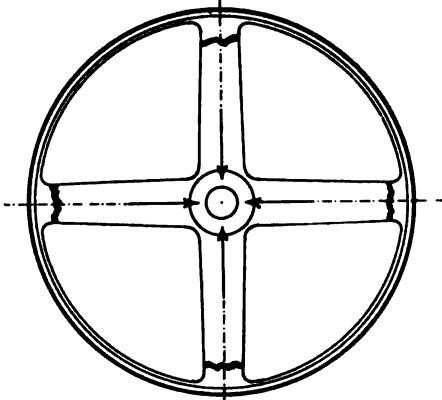

FIG. 126.
Contraction of Arms and Rim of Wheel or Pulley.

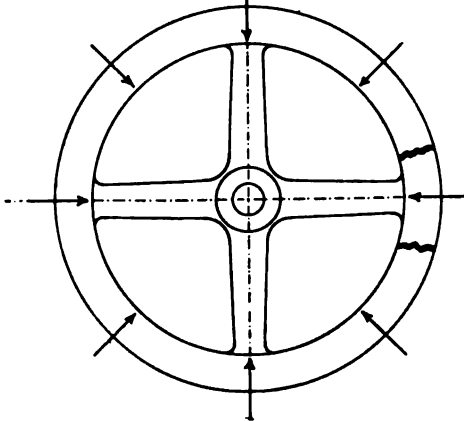

FIG. 125.
Contraction of Arms and Rim of Wheel or Pulley.

This is, however, a very difficult form of section to cast without running great risks of setting up internal stresses of considerable magnitude. Not only is this the case with regard to the several parts of the cross section, but the unequal rate of cooling makes



FIG. 128.—Section of Cast Iron Girder.

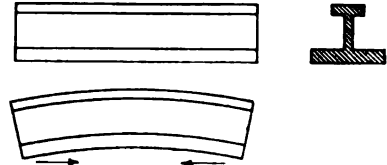

FIG. 129.—Contraction of Cast Iron Girder.

itself felt in a longitudinal direction also, and as the thick bottom flange continues to contract long after the top flange has cooled and set, the girder becomes curved when cold, as shown in Fig.

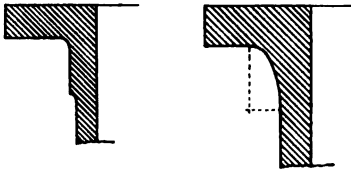

FIG. 130. FIG. 131.
Junction of Flange.

129. There is little doubt that the existence of contraction stresses has been largely responsible for many cases of sudden fracture at less than working load, and has done much to discredit the use of the cast iron girder. Although for other reasons, cast iron may not be

an altogether suitable material for this purpose, it is worthy of note that in many recent designs the difficulty has been overcome by making top flange, web, and bottom flange of the



FIG. 132.—Thick Flanges on Engine Beds.

same thickness throughout, Fig. 128 (b), in accordance with the rule previously quoted. It should be realised that the production of a sound and reliable casting, free from initial stresses, is of

vestly more importance than the saving of a few hundred-weights of a comparatively cheap material. It will, however, occasionally happen that perfectly valid reasons may be given why the rule should be departed from. Thus, the flange of a cylinder or pipe should obviously be thicker than the body, but the transition should be effected as gradually as possible. For this reason, a belt intermediate in thickness between that of the flange and the body may with advantage be arranged immediately behind the flange, as in Fig. 130. Heavy flanges are sometimes attached to the body by quarter elliptical curves, as in Fig. 131, with the same object. Thick

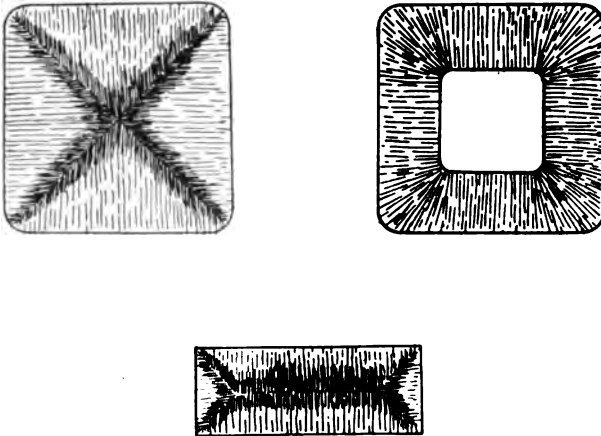

FIG. 133.—Cooling and Contraction of Rectangular Block.

flanges on engine beds and similar parts are often adopted for the sake of appearance, or to obtain stiffness, and it is better that they should be hollowed out to preserve a fairly uniform thickness of metal as at (b) rather than cast solid, as at (a), Fig. 132.

Another influence which may seriously affect the strength of a casting is the direction of crystallisation. The molecular aggregation of crystalline solids follows a definite law, and when a fused solid is in the act of cooling and crystallising on solidification, the crystals arrange themselves with their principal axes in the direction of the flow of heat, or of the heat wave passing from the body. This is determined by the direction in which heat is

radiated during cooling, which causes the crystals to set themselves along lines at right angles to the external surface of the casting. The section of a rectangular block of cast iron, whether solid or hollow, will thus appear as shown in Fig. 133, and it will be seen that the lines of crystallisation intersect at the corners, forming diagonal planes of separation along which fracture is liable to take place. Formerly, the bottom of a hydraulic press cylinder was made flat, with corners of

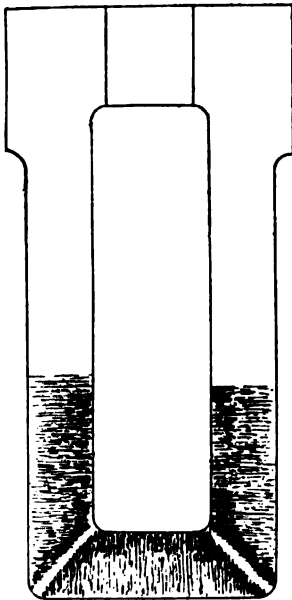

FIG. 134.—Hydraulic Press Cylinder with Flat End.

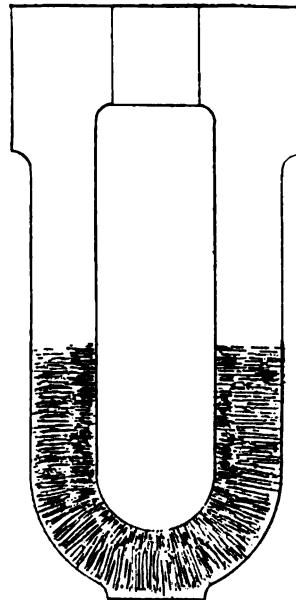

FIG. 135.—Hydraulic Press Cylinder with Hemispherical End.

small radius, and it was found that fracture was particularly liable to occur in a conical direction, as indicated in Fig. 134. The trouble was entirely obviated by adopting a hemispherical form for the end, by which continuity of the lines of crystallisation is obtained, without any plane of weakness due to abrupt changes in the radiating surface, Fig. 135. Sharp square corners, or "re-entrant angles," whether external or internal, are always liable to start a fracture in whatever position they occur, Fig. 136, and it is an important rule

that they must always be avoided in designing any casting, as seen in the following examples, Fig. 137.

As the melting point of steel is probably about 2900° F., as compared with 2200° for cast iron, it follows that the contraction of steel is much greater than that of cast iron, being on an average about $\frac{1}{4}$ inch instead of $\frac{1}{8}$ inch per foot. Special precautions must therefore be taken to avoid the danger of steel castings "flying" during this excessive contraction. To prevent the possibility of accident from this cause, they are taken out of

the mould as soon as the metal is set, put into an annealing furnace maintained at a temperature of 1700° F. for about 24 hours, and allowed to cool down without admission of air, the time depending upon the size of the casting.

A prismatic block or ingot of steel always contains a hollow pear-shaped cavity near the top due to

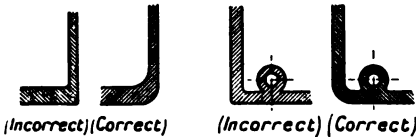

FIG. 137.—Square and Rounded Corners.

shrinkage and contraction in cooling. Fig. 198 shows successive zones of solidification, and a section through the ingot when cold. A thick crust first forms round the outside and over the top, the still liquid metal in the interior gradually sinking by its own weight as solidification proceeds. The total contraction in volume is probably about 9 per cent., of which $6\frac{1}{2}$ per cent. is accounted for in the direct contraction of the exterior, the hollow cavity or "pipe" representing the remaining $2\frac{1}{2}$ per cent. To obviate this defect, the casting is made with a "head," which is afterwards cut off to secure soundness in the remaining portion.

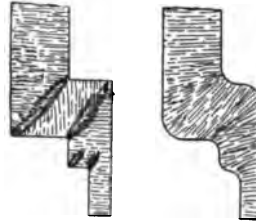

FIG. 136.—"Re-entrant" Angles.

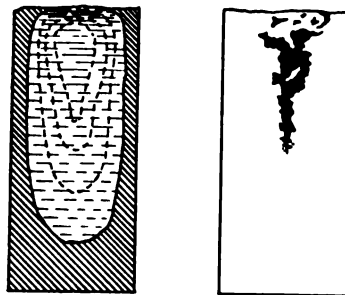

FIG. 138.—Cooling of Steel Ingot.

CHAPTER XXII.

METHODS OF MOULDING.

THE material of which a mould is made must possess sufficient cohesion or bond to resist the fluid pressure of the molten metal without change of shape, and at the same time, it must be plastic and capable of taking a perfectly sharp impression from the pattern. It should be refractory in a high degree, and must not melt or become mixed with the molten metal which comes in contact with it. It must be to some extent porous, to permit the ready escape of gases which are always given off when hot metal is poured into a mould, and it is important that it should be a bad conductor of heat to prevent too rapid cooling, which in the case of iron at least, leads to the production of "chilled," and extremely hard castings. The materials best answering these requirements are quartz, sand, and clay, to which may be added other substances for the purpose of imparting desirable properties. Sand for moulding must not contain organic matter, chalk, or other substance likely to suffer decomposition at a high temperature. A good sand, in its natural condition, should consist of nearly pure silica, a small quantity, say from 2 to 5 per cent., of clay being desirable to impart the necessary plasticity, and enable the sand when moistened to take and retain a sharp impression. For the same reason, the grains must be fine and sharp and of uniform size, say $\frac{1}{250}$ of an inch. Sea-sand, being round and smooth, is quite unsuitable. It is, however, well adapted for making intricate cores, as explained later (p. 256). The sand as it comes from the pit is dried, and ground in an edge runner mill, powdered coal being added during the operation. This gives the sand the black appearance which is always noticed in the foundry, although naturally it is of a yellow or reddish colour. The thorough admixture of finely-powdered coal or other carbonaceous matter protects the sand from the action of the hot metal, preventing it from being fused and dissolved by the casting. Other-

wise a hard siliceous skin would be produced on the casting, which would prove exceedingly troublesome to remove in machining. The floor of the foundry is formed on a bed of cinders or coke, on which a good thickness of ground sand is spread in layers with the shovel, each layer being moistened with a watering can and thoroughly turned over. The ordinary damp sand of the foundry obtained in this way is known as *green sand*, not, of course, from its colour, but because it exists in its naturally moist condition. The same sand remains constantly in use, mixed with new from time to time, and the whole damped after each using.

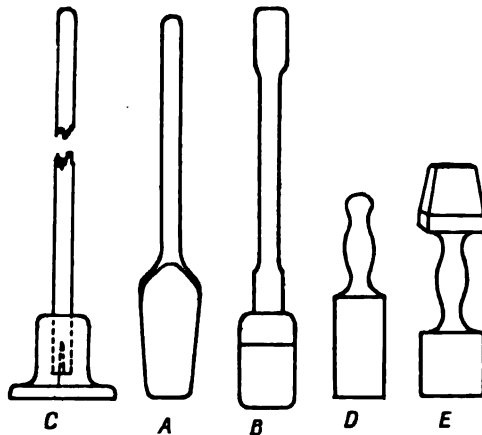

FIG. 139.—Moulder's Tools. Rammers.

Moulding comprises three distinct branches:—(1) *Greensand*, (2) *Dry sand*, and (3) *Loam moulding*. With either of the first two methods, patterns, usually made in wood, are necessary, but in loam moulding, which is chiefly applicable in the case of large objects of circular form, patterns are dispensed with. The tools employed by the moulder for greensand or dry sand work should first be noticed. To take out lumps, dirt, and foreign matter, the sand is sieved through a *riddle* having a mesh of about $\frac{1}{4}$ inch. The sand is thrown upon the riddle, and filled into the boxes by means of a *shovel*, and is packed closely round the pattern and into the box by *rammers* (Fig. 139), which are of two kinds, "pegging" and "flat." The former shown at *a* and *b* have flat

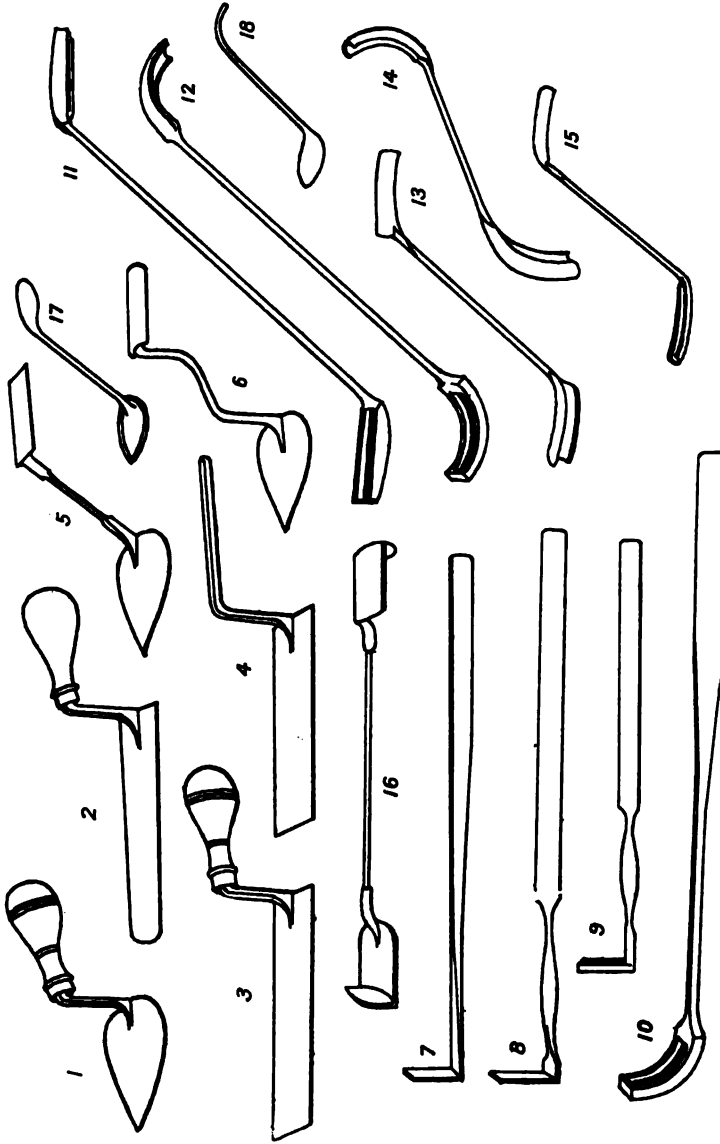

FIG. 140.—Moulder's Tools. Trowels, Cleaners, Sleekers, etc.

1. Broad Heat Trowel.
2. Taper Trowel.
3. Square Trowel (English).
4. Scotch Trowel.
5. Heart and Square Trowel.
6. Gate Knife.
7. English Cleaner.
8. Scotch Cleaner.
9. Scotch Club Cleaner.
10. Flange Cleaner.
11. Girder Tool.
12. Flange Bead Upset.
13. Fluted Bead.
14. Circular Bead.
15. Straight Bead.
16. Boss Tool.
17. Spoon Tool.
18. Sleeker, or Dog Tail.

ends with rounded faces, for entering narrow spaces, and for commencing operations; the latter, as at *c* and *d*, have flat faces for final ramming and finishing. Short rammers for bench work are shown at *d* and *e*, the latter being combined pegging and flat. These are usually turned out of hard wood. Recently, pneumatic rammers, operated by compressed air, have been used with great success for large moulds, and for pit work. In Figs. 140 and 141 are shown the small steel tools used by moulders. These comprise: *Trowels*, of square and heart shapes for filling small moulds or mending broken places; *gate knives*, for cutting gates and risers; *cleaners* and *beads*, for repairing and cleaning up the

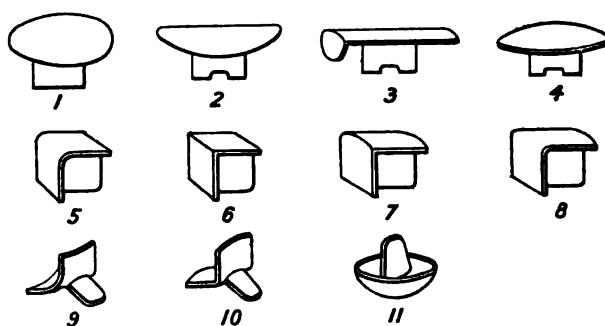

FIG. 141.—Moulder's Tools. Smoothers.

1. Egg Smoother. 2. Pipe Smoother. 3. Safe End Pipe Smoother. 4. Bacca Box.
5. Round Edge Corner Smoother. 6. Square Corner Smoother. 7. Round Edge
Flange Corner Smoother. 8. Flange Corner Smoother. 9. Round Edge External
Corner Smoother. 10. Square External Corner Smoother. 11. Button Smoother.

surface of the mould, especially in deep places; and *smoothers* and *sleekers*, of various shapes for smoothing out square or rounded corners either externally or internally. *Vent wires* or *prickers*, by which the mould is perforated in various directions to permit the ready escape of any gas, are also required. Levels, plumb bob, and straight-edges, camel-hair brushes for coating the interior of a mould with blacking, bellows, and hand-brushes, complete the moulder's equipment.

Greensand moulding in its simplest form is carried out in the sand of the foundry floor, the mould being quite open without cover, so that all parts are visible, from which the name *open sand moulding* is derived. It is applicable to flat plates, wall plates, window frames, moulding boxes, core grids, grates, and

comparatively unimportant work of that class. As the mould is perfectly open, the upper surface of the casting is always rough, and the corners much rounded, due to capillary action. In preparing the mould, the floor sand is opened out and watered, and by means of straight-edge and plummet brought to a level surface, over which fresh sand is riddled. Upon this the pattern is laid, and fixed in position by gentle tapping. It is then covered with fresh sand and rammed up to a level surface, the impression being repaired, if necessary, after removal of the pattern. A small cavity, or *pouring basin*, is formed at one end of the mould, to

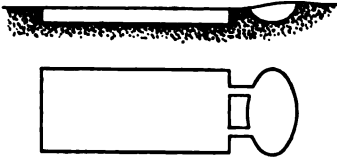

FIG. 142.—Open Sand Mould.

which it is connected by two or more shallow channels or *sprues*, cut out by the moulder with the tools previously described. The mould, Fig. 142, is then dusted out with finely-powdered plumbago or wood charcoal contained in a muslin bag, flat surfaces being polished over by the trowel, and corners smoothed out by sleekers. Should the casting be of fairly large size, a pricker would be thrust through the base of the mould in several directions, to provide a passage for any gas which might be disengaged on casting. Molten metal is poured into the basin until the mould is completely full, when the surface is sprinkled with sand to retard cooling of the open surface. Rough castings for the frames or grids of cores, such as shown in Fig. 143, are often made without patterns, grooves of the required section being cut by the moulder in the sand. The example given is that of a grid for the core between the arms of a fly-wheel or rope pulley. As the core is a large and heavy one, three bosses are provided, in holes through which the hooked ends of lifting rods may be inserted.



FIG. 143.—Core Grid.

Moulding in Boxes.—In this system of moulding, the sand is contained in *boxes* or *flasks*, which are generally rectangular frames of cast iron without top or bottom, Fig. 144, and are usually

employed in pairs, the top and the bottom box together forming the mould. In order to take out the pattern, the boxes must be separated from each other, and to ensure that they may be readily

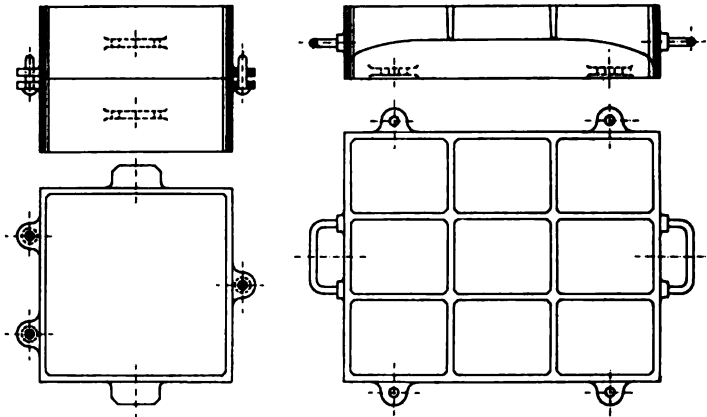

FIG. 144.—Moulding Boxes.

put together again in exactly the same position as before, lugs are cast on the sides, those on one box having projecting pins

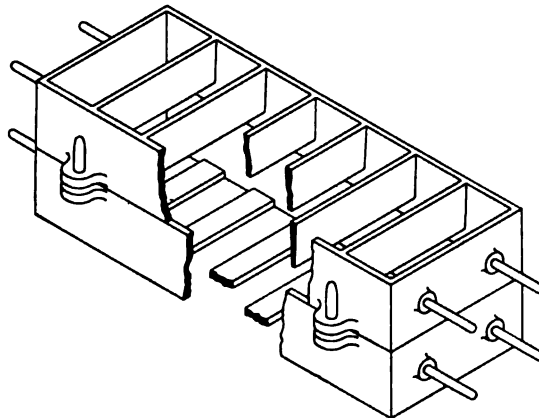

FIG. 145.—Moulding Boxes.

which enter holes in the lugs of the other box. Handles in the form of flat projections are also provided for lifting, and trunnions are cast upon the ends of very large boxes, so that

they may be slung from the crane. For large castings, the foundry floor is frequently made to do duty in place of the bottom box, whilst for objects of complicated form it may be necessary to employ three or more boxes in combination. To hold the sand, and prevent the possibility of its falling out when the box is lifted, bars are cast across medium and larger sized boxes, as in Fig. 145. In America, wooden boxes are preferred on account of lightness, but they are liable to suffer from the combined effects of heat and moisture, and are not durable. For special and repetition work, boxes are made of a size and shape to suit the

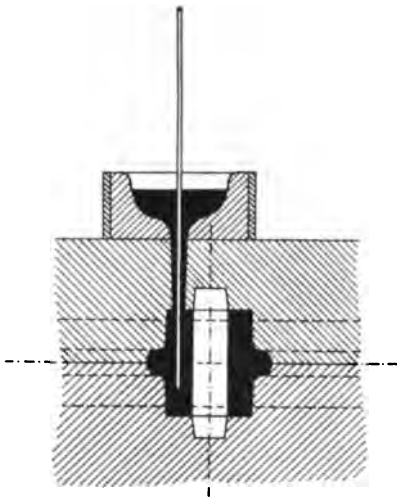

FIG. 146.—Feeding Gate.

object to be cast, thus avoiding the trouble of filling useless space with sand, as would happen if irregularly-shaped articles were moulded in rectangular boxes large enough to contain them.

Certain general principles are involved in two-part moulding, *i.e.*, whenever boxes are employed, and the mould is closed. The hollow cavity, or impression left by the pattern in the sand, must be put in communication with the outside for several reasons. An opening termed the *pouring gate* or *runner*, must be provided, through

which the molten metal may be introduced, and its outer orifice must always be above the level of the highest part of the mould, so that the latter may be completely filled. If the mould is shallow, the pouring gate may enter it direct, but in order to avoid damage to the mould by impact of the incoming stream of metal falling to any appreciable depth, it is better to form the gate at the side, leading in the metal through two or more separate channels or *sprues* near the bottom of the mould. To prevent straining and the formation of blow-holes, the air must be allowed to escape as the metal enters, and for this purpose, a *riser* or *air gate*, opening from the highest point of the mould, must

be provided. This also serves to show when the mould is full, pouring being continued until the metal appears at the surface. To compensate for internal shrinkage, a *feeding gate* or *head*, Fig. 146, should be provided, communicating directly with the boss or other thick portion where a "draw" is likely to occur. After pouring, a piece of round iron bar about $\frac{3}{8}$ inch diameter, known as a feeding rod, is inserted in the head, and is moved up and down in the molten metal. The agitation thus set up is sufficient to maintain a clear way through into the interior, through which fresh metal from the head may enter, or may be poured in from a hand ladle, to make up for the loss due to liquid shrinkage. The action is continued until the metal is just upon the point of solidification, when no further shrinkage is likely to occur. The size, shape, and position of the gates are usually left to the judgment of the moulder, who keeps by him a number of tapered wooden plugs of various forms to be used as patterns for this purpose. When the mould is full, the liquid metal is under a pressure due to the head in the pouring gate, and the result is a tendency to lift the top box, or in other words, the top box being lighter, tends to float upon the liquid metal in the mould. The boxes must therefore be clamped together, or the top box may be loaded with cast iron blocks, the weight of which exceeds the weight of the liquid metal in the mould. The sand in some parts of the mould is rammed tighter than in others, depending mainly on the pressure of liquid metal to which it is subjected.

Example of Moulding in Boxes.—Suppose a simple flat object, Fig. 147, is to be moulded, the wooden pattern is laid upon a "turn-over board," and the bottom box is placed round it in an inverted position, Fig. 148. The pattern is first covered with fresh or "facing" sand from a riddle, and the box is then filled up with previously-used sand, and well rammed down, first with the pointed, and afterwards with the flat, rammer. The superfluous sand is struck off with a rule, and the box, still resting upon the board, is turned over, the board being then taken off. The upper surface (which previously rested upon the board) is made perfectly smooth and level with the trowel, and upon it is sprinkled a thin layer of *parting sand*, which is the burnt sand or dust scraped from castings. This prevents the sand in the top box adhering to that in the bottom box, so that the two halves of the mould may be easily separated for removing the pattern. The

top box is now fitted upon the bottom one, facing sand is thrown in, followed by old sand to fill the box, gate and riser patterns are inserted, and the box rammed up, Fig. 149. After taking out the gate plugs, the top box is lifted off, and laid upside down upon the bench. The pattern, still in the bottom box, is lightly "rapped" to loosen it in the sand, and is carefully lifted out.

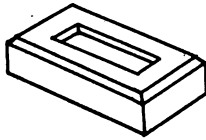

FIG. 147.—Simple Object for Moulding.

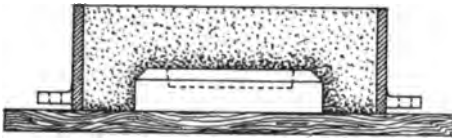

FIG. 148.—Moulding Bottom Box.

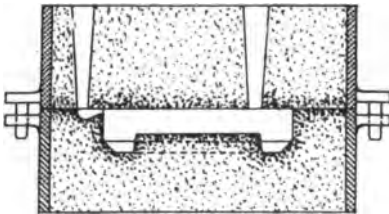

FIG. 149.—Complete Mould ready for Pouring.

If an attempt be made to remove the pattern without rapping, the sand will adhere to the edges, and the mould will be broken. Rapping is generally performed by boring a hole in the end of a round bar, or the bar is sometimes made red hot, and allowed to burn its way into the pattern. By striking the vertical bar on all sides, the pattern is caused to rock very slightly and thus free itself in the sand. The mould is thus made somewhat larger than the pattern, to an extent which, in small objects, renders any allowance for contraction unnecessary. The process of rapping, although indis-

pensable, may be the cause of serious damage to patterns, and to avoid this as far as possible, metal "rapping plates," Fig. 150, are let into large patterns flush with the top surface. A useful modification is to provide in one and the same plate a plain hole for rapping, and a tapped hole to take the screwed end of a lifting rod, which is often a great convenience when taking out the pattern from the mould. The mould is then repaired if necessary, and the flat surface smoothed over with the trowel, a "facing" of powdered plumbago or charcoal being dusted

on during the polishing process. The top box is treated in the same manner, placed in position on the bottom box, and loaded, ready for pouring. The "parting" of a mould need not necessarily be made on one flat plane at the junction of the two boxes. It must, however, in all cases commence at the upper edge of the bottom box, and it must intersect the pattern exactly where the

latter attains its maximum width. Thus the parting must meet a sphere exactly on the section of maximum diameter measured horizontally, and it must intersect a cylinder on a horizontal plane passing through the axis. The patterns for such objects may therefore be very conveniently constructed in halves, so that the moulder experiences no difficulty in locating the parting. In the case of a solid sphere, for instance, the half pattern is placed on a turnover board, and the bottom box moulded in the usual way, Fig. 152. The box is then turned over, the board removed, and the

other half of the pattern fixed upon that already in the sand. To bring the two halves of the pattern together in the correct position, "dowels" are used, either in the form of wooden pins driven into one part and fitting exactly into holes bored in the other, or by letting into the flat surface of each half, specially made dowel plates of metal, Fig. 151. The mould is completed in the same manner as before, Fig. 153.

Cores for Hollow Interiors.—Hollow objects require to be "cored out," by means of a "core" made in sand to the exact

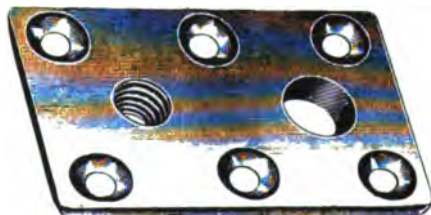

FIG. 150.—Rapping Plates.



FIG. 151.—Dowel Plates.

shape of the hollow interior. The pattern-maker constructs a wooden mould or "core-box," in which sand is rammed

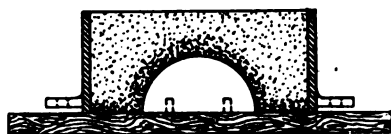

FIG. 152.—Moulding Bottom Box.

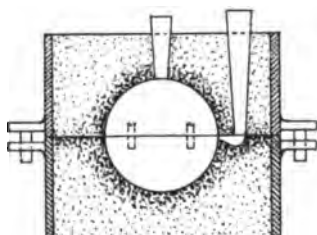

FIG. 153.—Complete Mould for Solid Sphere.

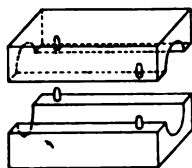

FIG. 154.—Core Box.

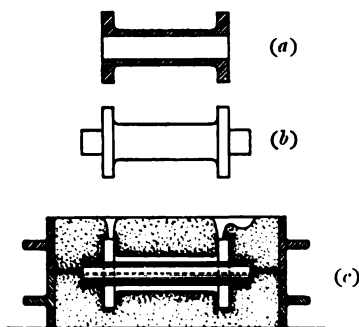

FIG. 155.—Mould for Short Pipe.

up to form the core. The core-box is usually in two or more pieces, suitably jointed or "dowelled" together, to permit the withdrawal of the core without risk of damage in handling. Fig. 154 shows a core-box in halves, in which the core for a hollow cylinder would be made in "dry sand," or common moulding sand mixed with sharp sand. Core sand should be fairly adhesive, and yet porous enough to secure free venting, and it should admit of being easily extracted from the casting. Sea sand or sand free from alumina is most suitable, the necessary bond being obtained by the addition of a "binder" such as core gum, linseed oil, flour, or resin. The binder burns immediately the molten metal comes in contact with it, leaving the core entirely free from gas. Consequently there is no danger of blowing, and except when of large size, or of complicated form, cores made in this way require neither irons nor vents, and are easily cleaned out of the casting. The sand is well damped before being rammed in the box, and the

core when made is placed in a stove to dry. While still warm, a coat of "blackwash" is put upon the surface to prevent the molten

metal from fusing and dissolving the core. Blackwash is made from "moulder's blacking," which is a carbonaceous residue obtained from the retorts used in distilling shale, and which is mixed with clay water to the consistency of cream. The core must be supported in the proper position in the mould, and this is usually effected by allowing its ends to rest in impressions left by the pattern for the purpose. Suppose a short pipe having a

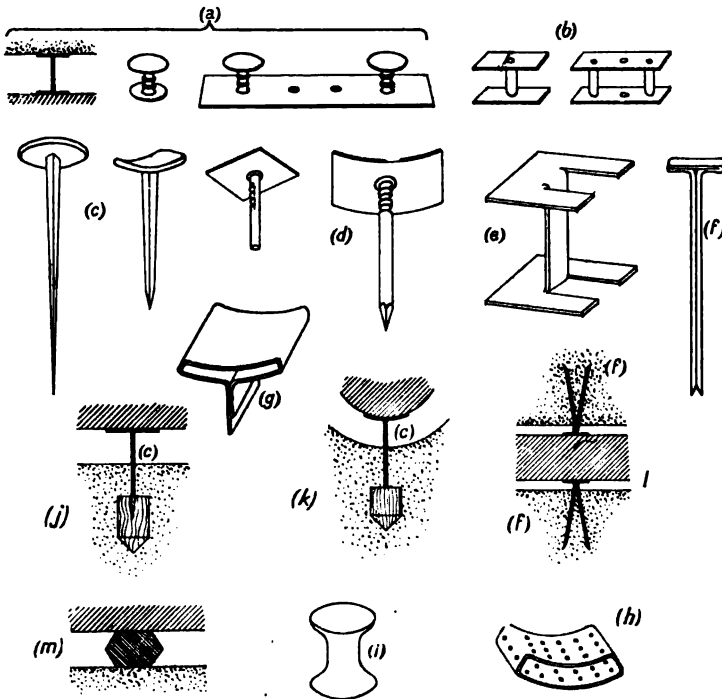

FIG. 156.—Various Forms of Nails and Chaplets.

flange at each end, Fig. 155, *a*, is to be moulded. The pattern, Fig. 155, *b*, preferably in halves, would be provided with a "core print" at each end, these prints being of the same diameter as the core, and of a length sufficient to afford the necessary supporting surface. The mould would be made by the method described for the solid sphere, and when complete, with the core in position, would appear as in Fig. 155, *c*. It will be seen that the core is longer than the hole in the casting by the combined

length of the core prints. The core-box is shown separately in Fig. 154.

Long and awkwardly-shaped cores require strengthening, as otherwise they would be liable to bend or break under their own weight or the upward pressure of the fluid metal. A skeleton of bent wire, or of light rods, or a "core iron" specially cast in open sand for the purpose, may be inserted to impart the necessary stiffness. A core iron should be of such shape and thickness as may be readily broken up for removal when the casting is fettled. A piece of wire twisted to form a handle for lifting out the core, may be left protruding above the surface of a sinking, which is filled up and smoothed over when the core is finally placed in position. Long cylindrical cores for pipes, etc., are

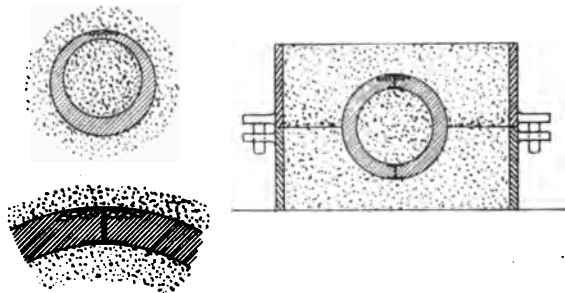

FIG. 157.—Defect due to use of Chaplet.

formed on "core bars," which consist of iron pipe perforated with a large number of holes to provide for the escape of the gases. A core may be still further supported by means of "nails" or "chaplets," which are made in a number of different styles, shapes, and sizes, Fig. 156. As chaplets remain "cast in," or embedded in the metal, it is important that they should possess at the time of using a clean metallic surface, perfectly free from rust, and for this reason they are always tinned or galvanised. Chaplets or nails punched out of sheet metal *e, f, g,* and *h,* are preferable to those made in two or more pieces rivetted together, as *a, b, c,* and *d.* The method of employing chaplets is shown at *j, k, l, m,* in Fig. 156, and further illustrations of their use will be found in many of the examples of moulding which follow. It must, however, be admitted that the use of chaplets is not altogether free from objection, as they are

liable to become loose, and are often the centre of a blown or porous place, Fig. 157. When a long cored-out object, such as a pipe or cylinder, is cast horizontally, any escaping bubbles of gas will collect above the core, and any scum or foreign matter in the metal will also rise to the top of the mould. Blown places may thus be formed by gas and dirt adhering to the chaplets.

These difficulties may be overcome by casting long cylindrical objects, such as pipes, plungers or rams, steam or hydraulic cylinders, etc., in a vertical position, which has the further advantage that a "dead head" may be left on the casting into which scum and ashes or "sullage" may rise, and where gas

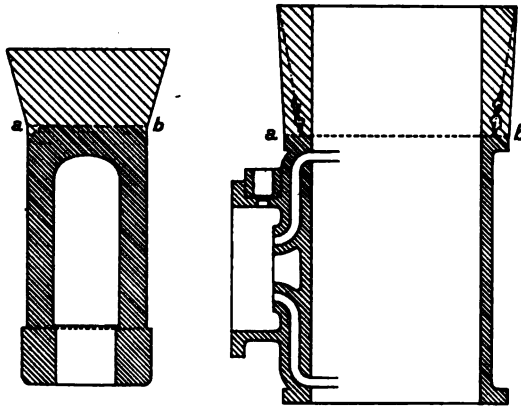

FIG. 158.—"Head" on Cylinder Casting.

may accumulate without risk of causing blown places in the casting proper, Fig. 158. The increased head causes additional pressure on the metal, and enables a sound casting to be obtained with certainty. The "head" is afterwards cut off on the line *ab*, in the process of machining. The arrangement of head shown in the figure on the right is not to be recommended, as the great mass of metal is liable to result in a "draw" (see p. 239). It is preferable to adopt the form shown in dotted lines, which avoids the risk of any sponginess on the face of the flange. Seeing that the soundest and cleanest metal will always be found where the pressure is greatest, it may be taken as a general rule that the most important part of any casting, especially any portion to be machined, should, whenever possible,

be placed at the bottom of the mould. Thus, in the case of a lathe bed, as the upper surface must be got up very true, and very clean, sound metal is required at this part, which must therefore be placed at the bottom of the mould, as will be explained later.

Bedding-in.—In greensand moulding, the process of “bedding-in” is often resorted to, that is, the mould is constructed as far as possible in the foundry floor, Fig. 159, the top box or “cope”

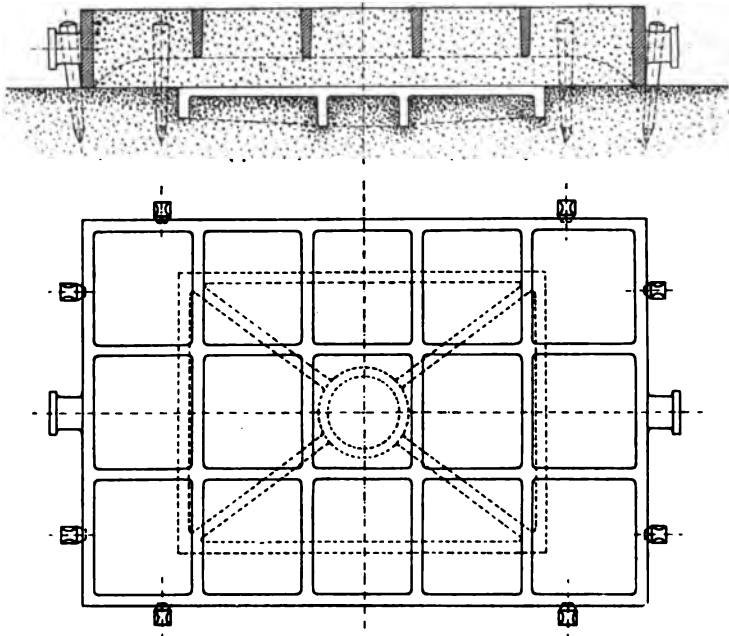

FIG. 159.—“Bedding-in.” Mould for Ribbed Plate.

being employed to secure the advantage of casting under pressure. Large wheels and pulleys are generally moulded in this way, Fig. 160. It will sometimes happen that portions of sand project to a considerable distance below the surface of the top box. These require to be supported by inserting “gaggers” of bent iron, which are “swabbed” with clay-wash, and hooked over the crossbars of the box as the sand is being rammed up. An interesting example of the use of gaggers, given by Mr. G. Hughes, Chief Mechanical Engineer of the Lancashire

and Yorkshire Railway, is shown in Fig. 161, which represents the mould for the cylinder cover of a locomotive engine, in which a recess has to be provided for the nut which secures

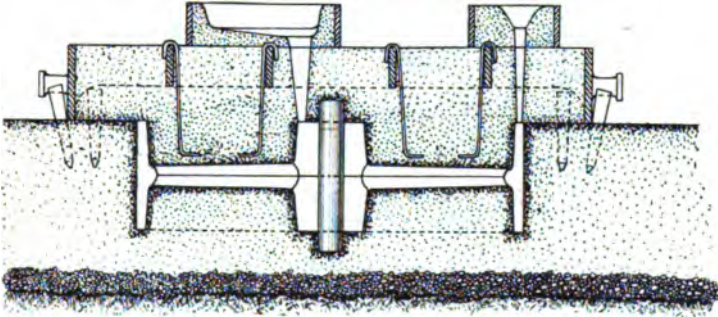

FIG. 160.—Mould for Large Wheel or Pulley.

the piston to its rod. The venting of the mould is shown by fine lines.

Recessed or Undercut Portions of a Casting.—For taking out recessed portions of a casting, three methods are available, viz.:

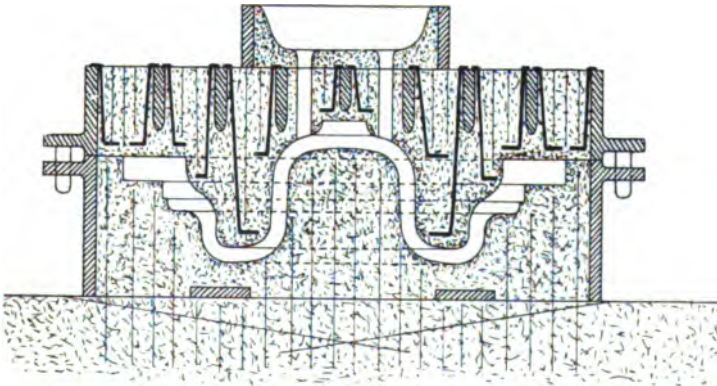

FIG. 161.—Mould for Locomotive Cylinder Cover.

(1) *loose parts* on the pattern; (2) "*drawbacks*," or portions of the mould supported on plates by means of which they may be withdrawn to facilitate the removal of the pattern, and afterwards replaced in position; and (3) *cores*, the most expensive method of

the three, and as a rule, only resorted to in cases of special difficulty. A good illustration of the use of a loose piece is given in Fig. 162. This shows the method of moulding a cylinder cover with stuffing

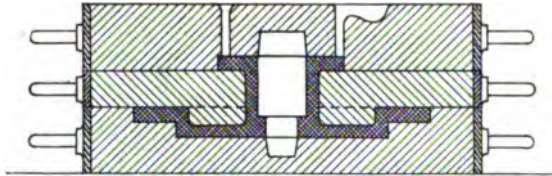

FIG. 162.—Use of Loose Piece on Pattern.
Mould for Cylinder Cover.

box, the flange of which is left loose on the pattern, and is lifted off in the top box. After taking out the flange, the top box is replaced, and is lifted off together with the middle box containing the pattern, which is then easily removed. The core is put in,

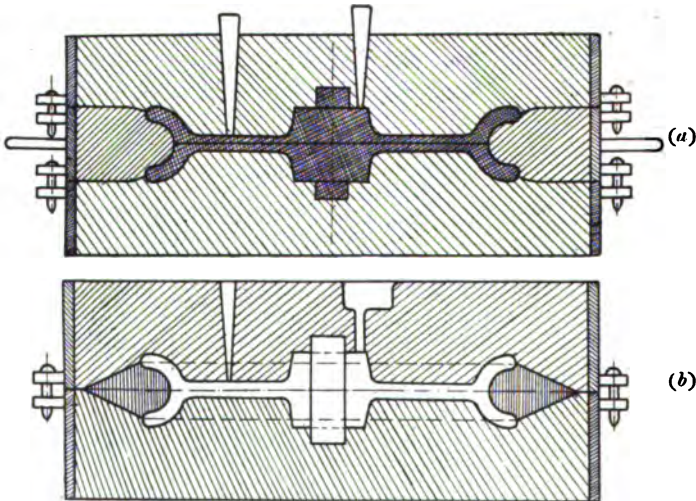

FIG. 163.—Moulding Chain Pulleys, etc.

and the mould completed in the usual way. It will be noticed that two partings are employed, necessitating the use of a "three-part" box. A somewhat similar expedient is adopted in moulding chain pulleys, worm wheels, etc. The pattern is made in halves, dowed together, the division passing through the

centre of the groove. It may then be moulded in three boxes, Fig. 163, *a*, without any difficulty. By means of the very ingenious device known as a "false core," the mould may, however, be made in two boxes, as in Fig. 163, *b*. This is effected

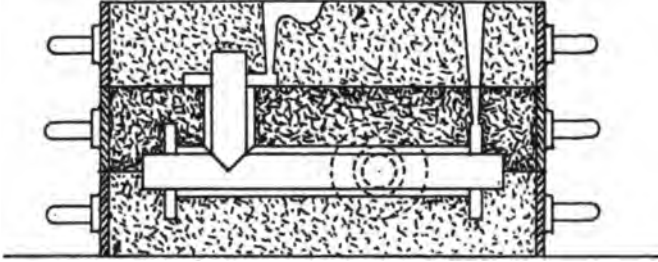

FIG. 164.—Three-part Mould for Branch Pipe.

as follows :—One half of the pattern is moulded in the bottom box, the parting being cut at an incline, as shown. The other half pattern is then put in position, and sand rammed in to form the second parting, sloping downwards from the upper flange. The

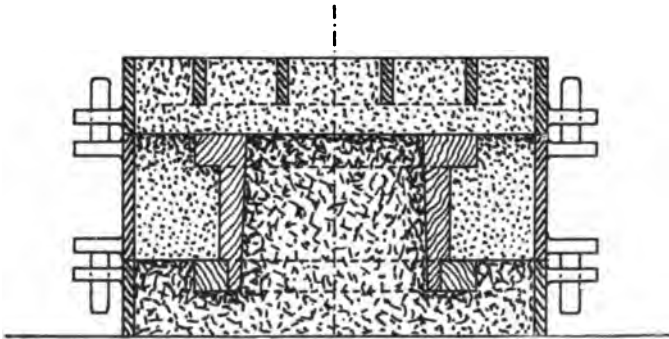

FIG. 165.—Moulding Flanged Object. Use of "Cod."

top box is next put on, and rammed up as usual. By taking off the top box, the upper half pattern may be got out quite readily, when the top box is replaced, and the mould turned upside down. The bottom box, which is now uppermost, is then lifted, and the remaining half of the pattern withdrawn. After replacing the bottom box, the mould is inverted, and may then be completed

in the usual way. It will be noticed that the ring of sand constituting the false core cannot be removed from the mould, but must always be supported on the box which, for the time being, is at the bottom. A three-part mould is also required for a pipe with branches at right angles, as in Fig. 164. The flange for the branch is loose on the pattern, and is made in halves doweled together, and fitted into a groove turned out of the branch.

Hollow objects with flanges when not very deep, may be conveniently moulded in three boxes, as in Fig. 165, the use of a core being avoided by taking out the interior by means of a block of sand, termed a "cod," attached to the bottom box. In this way

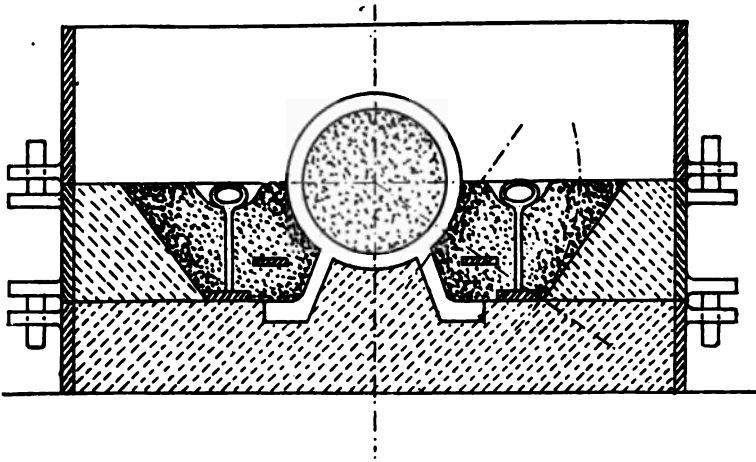

FIG. 166.—Use of "Draw-back" in Moulding Cylinder or Pump Barrel.

the inside of the pattern, "to leave its own core," must be "stripped," or made to taper in an upward direction, to avoid the tendency of the sand inside to "drag" or adhere to and lift with the pattern. The bottom flange is made loose on the pattern, and remains behind in the bottom box when the middle box containing the main pattern is lifted.

The Use of "Draw-backs" and Lifting Plates.—According to this method the recessed portions of the mould are formed upon plates by means of which they may be "drawn back" clear of the pattern, and then lifted out, leaving the pattern free for removal, after which the draw-backs are replaced, and the mould completed in the usual way. A familiar example, Fig. 166,

is a cylinder or pump barrel with feet attached, which is moulded in a three-part box, the draw-back plates being bedded upon the surface of the bottom box. A sloping "parting" joint is made from each plate to the main parting between the middle and top boxes, so that the sand between the sloping joint and the pattern

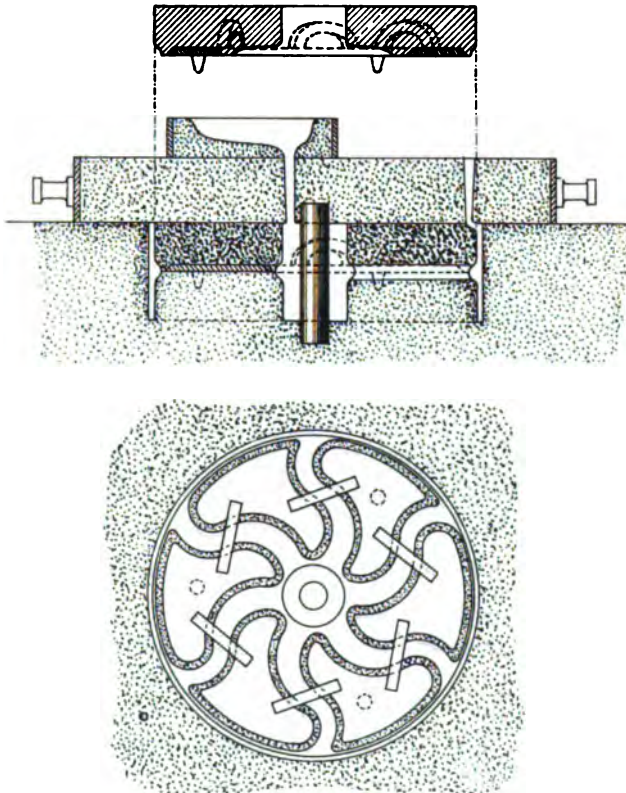

FIG. 167.—Moulding Wide-rimmed Pulley.

is carried entirely on the plate. Handles screwed into the plates are provided for lifting, during which operation the curved surface of the draw-back should be kept in contact with the cylindrical portion of the pattern until the rest is clear. The steam cylinder for a horizontal engine may be moulded in a similar manner, the addition of steam chest with steam and exhaust branches occasioning no further difficulty. This system of working,

in which a portion of the mould is lifted away on a plate, is very suitable for moulding wide-rimmed pulleys from standard patterns. In this case, the pattern is made of iron, with the rim in the form of a plain ring, separate from the arms, to which a loose boss may be fitted, half on each side. In each space between the arms and the rim, a cast-iron plate is fitted, the various plates being connected together by strong bridge pieces, as in Fig. 167. After ramming up the bottom box, the parting is formed at the centre of the pulley, and the lifting plate bedded in, as shown in the upper figure. Upon the plate, sand is now rammed up level with top of pattern, the top box is put on, and completed. By lifting off the top box, the rim pattern is first withdrawn, then

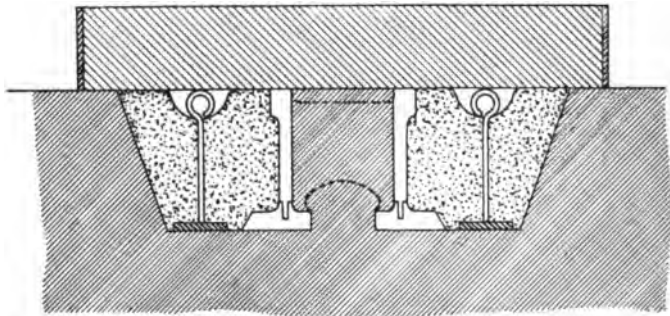

FIG. 168.—Moulding Lathe Bed with Draw-backs.

the lifting plate with the centre of the mould upon it, and lastly the patterns of arms and boss. To enable the lifting plate to be put back exactly in correct position, it is provided on the underside with three large pointed guide pins, which act in the same way as dowels. The core for the boss is inserted in place, and the top box then follows.

Lathe beds are moulded in several different ways, but unless special boxes are employed, lifting plates are almost indispensable. The bed is moulded in an inverted position, Fig. 168, to ensure sound metal for the face and vees, which latter are loose on the pattern, the sides being rebated to receive them. When the main body of the pattern is withdrawn, these pieces remain behind in the mould, and may be got out by lifting the outer sand away on plates, as shown. Where the design will admit of it, the sand forming the inside of the bed may be lifted out on a plate, Fig. 169,

which should be of wedge-shaped section, about 1 foot longer than the bed, and with two guide pins cast on its underside. The pattern is "bedded in" the foundry floor with the lifting plate in position, and is rammed up from inside and outside simultaneously. To bind the sand together, pieces of iron dipped in clay wash are inserted every few inches apart in the centre portion as the ramming up proceeds. The top box is rammed up as usual, a runner being left at each end on account of the great length of the casting. When complete, the top box is taken off, the body of the pattern drawn out, and the centre portion lifted out on its plate, two eyebolts being cast in the plate for the purpose. The loose pieces on the pattern are "wired on," and the wires are taken out as the ramming up proceeds. When the centre has

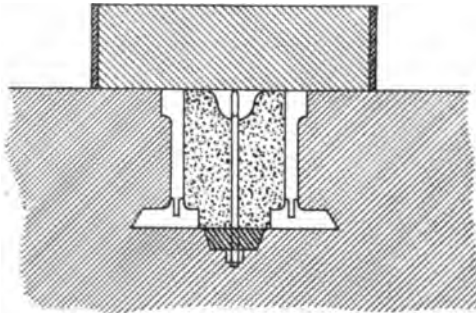

FIG. 169.—Moulding Lathe Bed with Inside Lifting Plate.

been lifted out, these loose pieces are withdrawn horizontally into the middle space then left free.

Probably the best method of moulding a lathe bed is to use a solid pattern and form the whole of the interior with dry sand cores. This has the advantages of being quicker and safer, and ensures a longer life of the pattern.

Where lathe beds are made in large numbers, special moulding boxes in four parts are sometimes employed. The mould thus consists of a bottom, two sides, and a top, which affords the moulder access to all parts for finishing, etc.

"Pot Mould."—This arrangement is in reality an adaptation of a very old device known as the "pot mould," employed in casting vases, urns, pots, and similar vessels, both in bronze and iron, Fig. 170. The pattern is made in halves, and is "self-coreing." The

mould is in four parts, bottom, middle (in halves), and top. The middle box is divided vertically, with the halves jointed accurately by means of pins and lugs, and bolted or screwed firmly together in addition. The half pattern, with the open mouth upwards, is rammed up inside the half middle box (1), against a vertical joint board temporarily secured to the box, the whole resting on a turnover board (a). The joint board is removed, and the surface left by it outside the half pattern covered with parting sand.

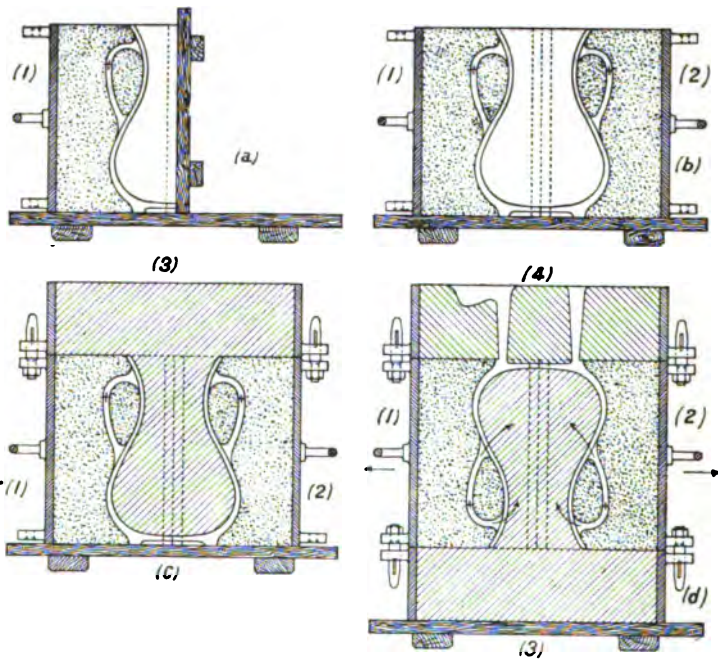

FIG. 170.—The "Pot" Mould.

The other half of the pattern is then added, the two halves being accurately fitted together by dowels, and after securing the second half of the middle box in position, the portion (2) of the mould is rammed up (b). Parting sand is sprinkled upon the upper surface, the bottom box is put on, and together with the inside of the pattern forming the core, is rammed up to give the portion (3) of the mould (c). By placing the bottom board on box (3), the whole may be turned over, bringing the object moulded into an inverted position. The turn-over board is removed, the

joint sprinkled with parting sand, and the top box put on and rammed up, leaving the necessary gates and risers (*d*). The pattern must now be withdrawn, and to effect this, after lifting off the top box, the bolts connecting the two parts of the middle box are removed, and by careful rapping, the two half boxes are drawn apart horizontally, exposing the pattern which, being in halves, is easily removed from the central core. If a handle is to be cast on the vessel, the pattern for it is wired on the main

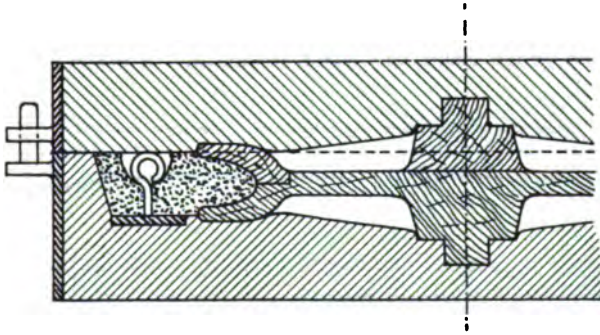

FIG. 171.—Moulding Grooved Pulley, with Ring Plate.

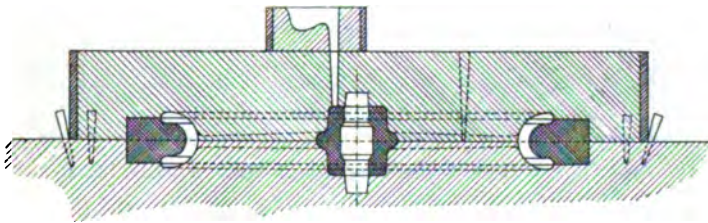

FIG. 172.—Moulding Grooved Pulley with Rim Core.

body, and therefore remains in the sand of one of the middle halves. The pattern for the handle is made in two pieces, each of which is curved to the arc of a circle to enable it to be drawn out of the sand as shown by arrows at (4). All parts are finally smoothed and finished, and the mould closed, the two halves of the middle box being securely bolted together.

Use of Cores for taking out Undercut Portions of a Mould.—As an alternative to the use of a false core, it would probably be preferable to take out the sand forming the groove of a rope pulley on a ring plate, Fig. 171, especially in the larger sizes.

Taking the same example, the transition from the lifting plate method to true coreing will be at once observed. In the latter case, the rim is provided with a core print in the form of a projecting ring, Fig. 172, and the core, made in a core-box of corresponding shape, is laid in the recess left by the circular print. Chain wheels having link recesses in their grooves, are invariably dealt with in this manner. The use of cores is, therefore, not limited to taking out a hollow interior, but is frequently resorted to for awkwardly placed surfaces on the outside of an object. From what has been said, it will be noticed that cores may be of green sand, dry sand, or loam. A *green sand core* is

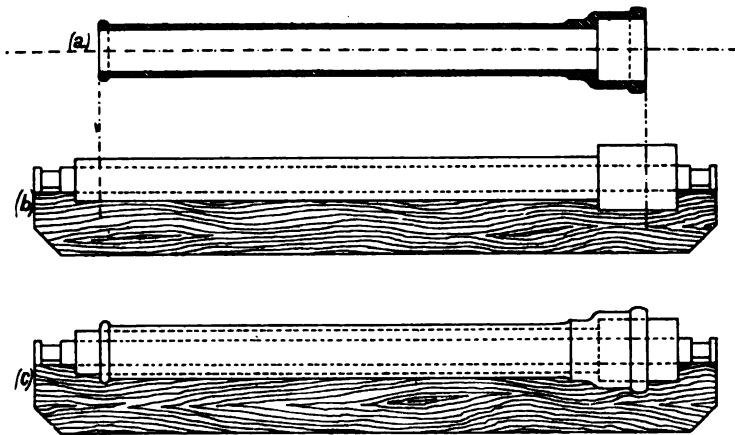

FIG. 173.—Method of Moulding Gas or Water Pipe in Loam.

one left by the pattern itself, without a core-box, and is formed from the same sand as the rest of the mould, to which, in fact, it is united by rods or grids, and which therefore is not subjected to any drying process. A *dry sand core* on the other hand, is invariably made in a core-box, and is afterwards dried in an oven or stove. *Loam cores*, to be next described, are usually “struck up” on revolving bars by means of a “strickle” or “loam board,” but are sometimes also made in open core-boxes. *Loam patterns* may be constructed in a similar manner, and are moulded in sand exactly in the same way as those of wood.

Pipe Moulding.—The method of moulding an ordinary gas or water pipe, Fig. 173, *a*, is a good illustration of the process. A

wood pattern might, of course, be used in the ordinary way, but it will now be shown how this may be dispensed with. The core is first formed on a *core bar*, which is hollow, made from iron pipe perforated with holes or air vents throughout its length to permit of the escape of any gases. The ends of the pipe are temporarily fitted with spindles, one of which is also provided with a winch handle for rotating the bar during the operation of building up the core. The spindle ends run in bearings formed on frames or "core trestles," thus constituting a rough kind of

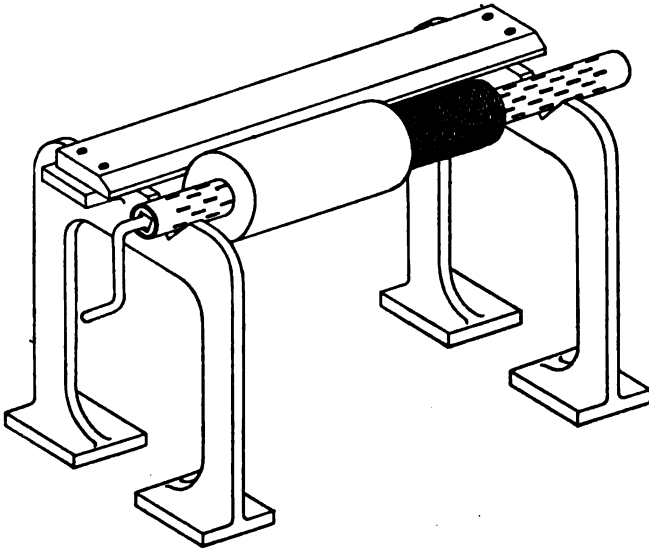

FIG. 174.—Method of Making Core for Pipe.

lathe, Fig. 174. A covering of hayband is first tightly wrapped round the bar throughout its length, and over this a coating of loam is applied, as the bar is revolved. This is allowed to dry, and if the core is of large diameter, a second layer of rope similarly covered with loam may be put on. In this way, the core is rendered porous or "self-venting," allowing easy escape of any gases through the holes in the core bar. When dry, more loam is laid on, and is stuck up to the required shape by means of the *inside loam board*, Fig. 173, *b*, fastened down upon the end frames parallel to and at the correct distance from the centre of the bar. The core is dried in the stove, and after receiving a coating of blackwash, is

again rotated in its bearings in order that the *thickness piece* may be added, *i.e.*, another layer of loam, brought up to the diameter and shape of the *outside* of the pipe by means of the *external loam board*, Fig. 173, *c*. After drying, the loam pattern is complete, and may be moulded in sand in the usual way. The thickness piece is then peeled off, the blackwash acting as a parting, leaving the inside core ready to be placed in the mould. Fig. 175 shows a section of the complete mould ready for casting. As already pointed out, long pipes should be cast in a vertical position. For this reason, a number of special appliances are made use of in a *pipe foundry* devoted exclusively to this class of work. Special boxes, Fig. 176, are employed for

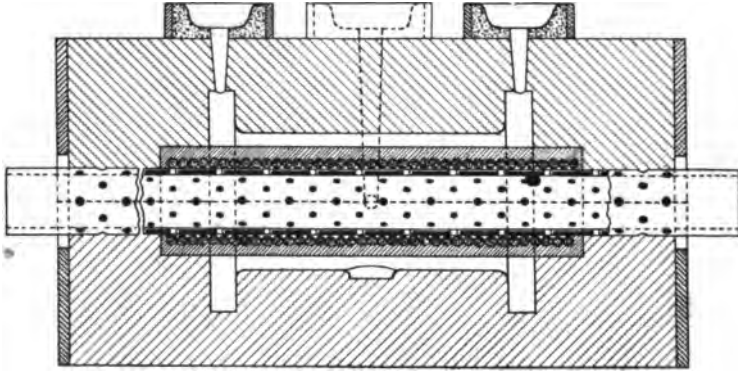

FIG. 175.—Complete Mould for Pipe or Cylinder.

each size of pipe, of such a diameter that a thickness of only 1 inch to $1\frac{1}{2}$ inches of sand is required for the mould. The pattern is of iron, in two parts, one to give the plain portion of the pipe, and the other the faucet end. The box is closed at the lower end by a hinged door, a recess in which enables the pattern to be placed in proper position without any trouble. Sand is then rammed in the narrow space left, to allow of which the upper part of the pattern is left loose, Fig. 176, *a*. When complete, the pattern is drawn out, first the faucet and then the shaft portion, and after receiving a coating of blackwash applied with a long-handled brush, the mould, Fig. 176, *b*, is dried by means of a portable stove. The core, made as previously described, is put in from above, centering itself by the conical

portion at the top, and by entering the recess in the door at the lower end, Fig. 176, *c*. It is desirable that pipes of large diameter should be cast with the faucet end downwards, as in Fig. 177. In a comparatively short time after casting the core bars are drawn while the pipe is still cherry red, and are stripped clean

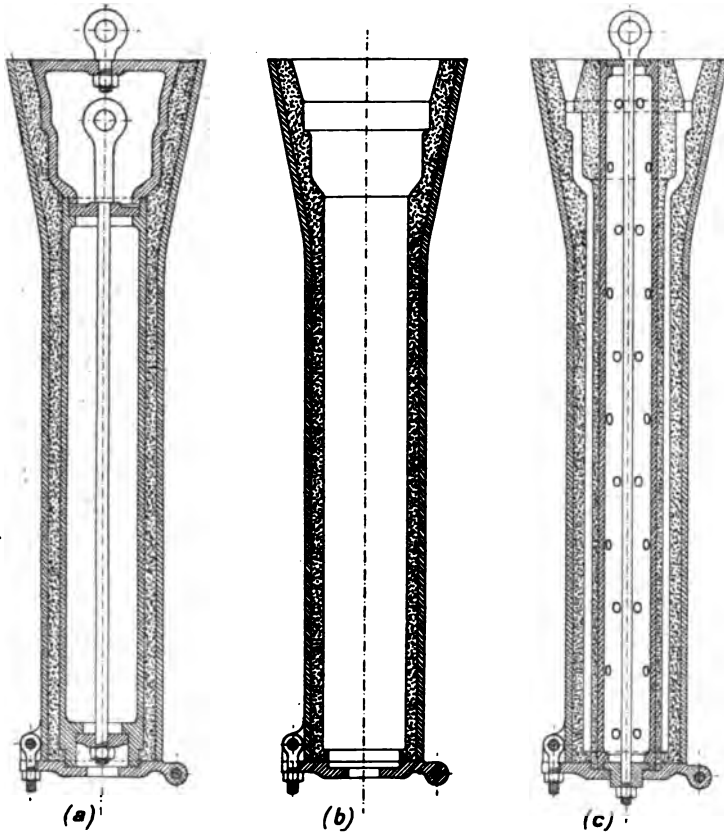

FIG. 176.—Pipe Moulding with Special Boxes.

from sand, etc., in doing so. The pipes are removed from the moulds while still red hot, when the boxes are knocked apart, cleaned out, and made ready for use again. To carry on work of this kind continuously, a casting pit is dug out to a sufficient depth below the foundry floor, in which the moulds may be stood on end. This is scarcely possible in the case of a long

cast-iron column for a building, which is usually cast "upon its side," or in a horizontal position. The complete mould for an example of this kind is shown in Fig. 178. Very great care must

be taken to prevent shifting of the core, which would of course produce unequal thickness of metal (see Fig. 157). The core must therefore be well supported by chaplets, both vertically and horizontally. Columns are poured from both ends, the runners entering the flanges. If very long and light, it is better to pour at the centre in addition, and in any case risers are arranged over the highest parts of the mould. There is always some danger of blowholes and sponginess on the upper side, and it is therefore most important that the mould should be well vented to permit the escape of gas.

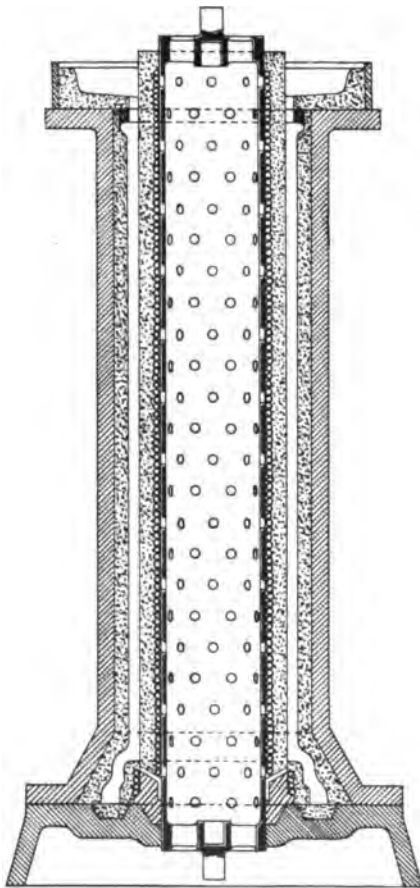

FIG. 177.—Complete Mould for Pipe with Spigot and Faucet Ends.

A further example of the use of a loam core occurs in *moulding a steam engine cylinder in dry sand*. Small, and even moderate sized cylinders not exceeding 30 inches diameter, are moulded from patterns in two boxes, Fig. 179, the

parting passing through the centre of the cylinder and the steam chest. The main core is formed upon a bar wrapped with hay-band and covered with loam as already described. The remaining cores are made in special core-boxes, those for the steam ports, Fig. 181, being particularly interesting examples of such work.

For holding the cores together, rods, frames of wire, or grids of thin cast iron, are inserted. Great attention must be paid to proper venting of the cores, which should be made to communicate freely with the outside air at all points of support on the mould, no opportunity being given for the gas to pass through the surface of the core into the metal. Hence it is desirable that the interior of the core should be of a porous nature, surrounded by a somewhat closer skin. This explains why cinders are often used for the centre, with a surface of fine sand coated with

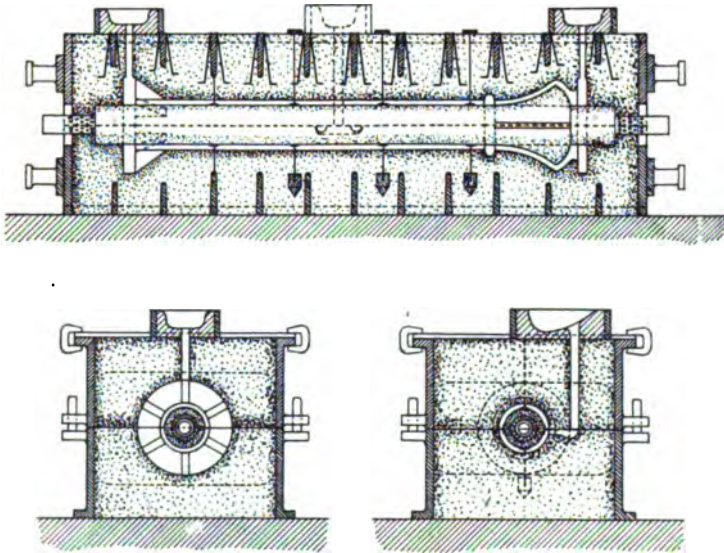

FIG. 178.—Complete Mould for Cast Iron Column.

blackening. With large cores, pipes are often arranged to lead from the coke body into the open air, where the issuing gases are ignited. In small cores, passages are left by ramming up the core round a small rod, or piece of wire, which is afterwards withdrawn. For small cores which are of curved or intricate shape, flexible "wax wire," which is produced in various sizes from $\frac{1}{8}$ th inch in diameter, affords a convenient means of obtaining thorough venting. When the core is dried, the wax melts, and is absorbed by the sand, leaving the required passage, through which the cotton wick may be withdrawn. After passing through the cores, the gas comes out at the prints, from which it must be

conducted away by suitable vents through the mould. These remarks apply with especial force to a complicated casting such

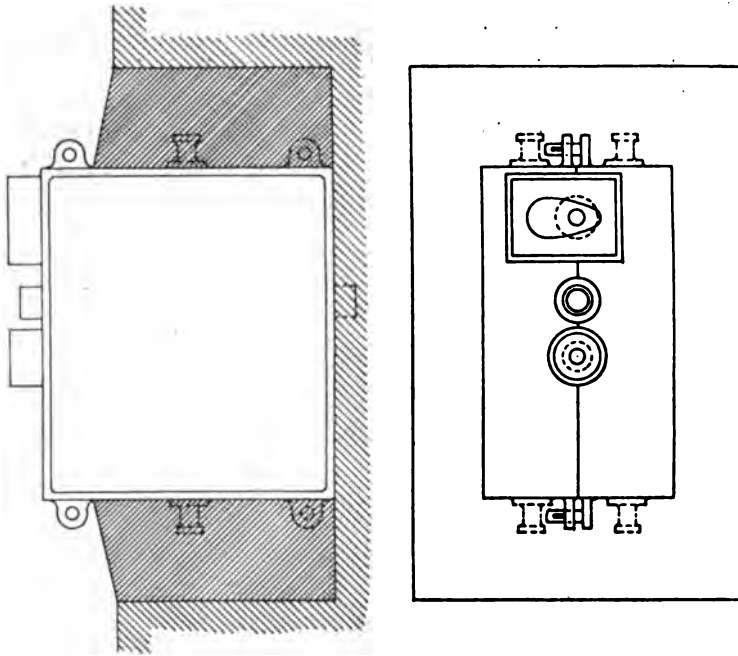

FIG. 180.—Mould with Pouring Basin, etc., embedded in Foundry Floor.

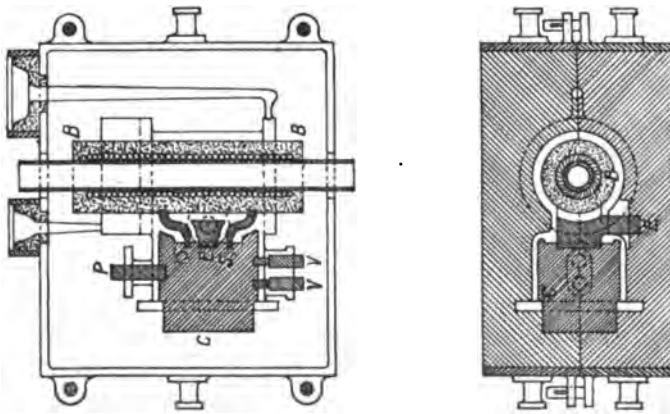

FIG. 179.—Steam Engine Cylinder Moulded in Dry Sand.

as a steam engine cylinder, in which, as a rule, the mould does not occasion much trouble, the cores giving the most cause for

anxiety. Taking the example given (Fig. 179), after moulding in the ordinary way, first the main core, B, and then the steam chest core, C, are placed in position, after which the steam and exhaust port cores, S, S, and E, are secured in their respective prints in B and C respectively. Lastly, the core, P, for the steam inlet, and those for the valve rod stuffing boxes, V, V, are fixed in their places, the mould closed, and the two boxes firmly clamped together. A pouring basin is arranged on the upper end of the mould, which is embedded in the sand of the foundry floor, as shown in Fig. 180. Deep moulds when complete are frequently

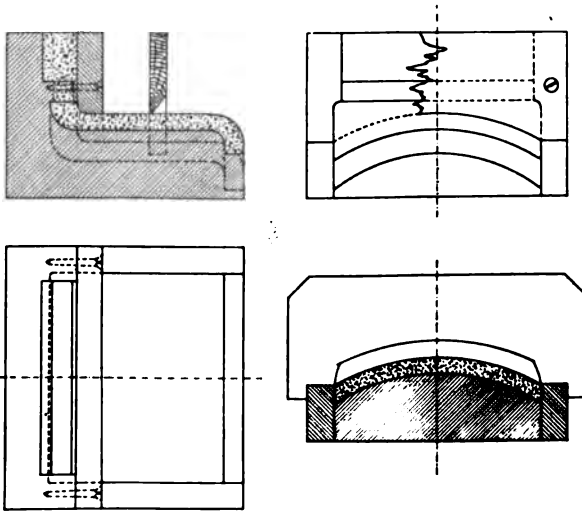

FIG. 181.—Core-Box for Steam Port Core.

rammed up in sand in this way, to guard against the possibility of bursting due to the head of metal inside (see Fig. 198).

An interesting example of cored work is found in the *main casting* for a vertical *direct acting steam pump*, constructed in the workshop of the engineering department of the Bradford Technical College. The photograph, Fig. 182, shows on the left the section set out full size on a board, the cores being indicated by section lining. The pattern itself is seen in the centre of the view, and the finished casting on the right. The steam cylinder, the main standard, which also serves as an air vessel and contains the valve chambers, the pump barrel, and the

base carrying the crankshaft bearings, are all "cast in one piece." In the view of the pattern, the various core prints are clearly seen, and grouped round the base, several of the core-boxes will be noticed. The rectangular print for the

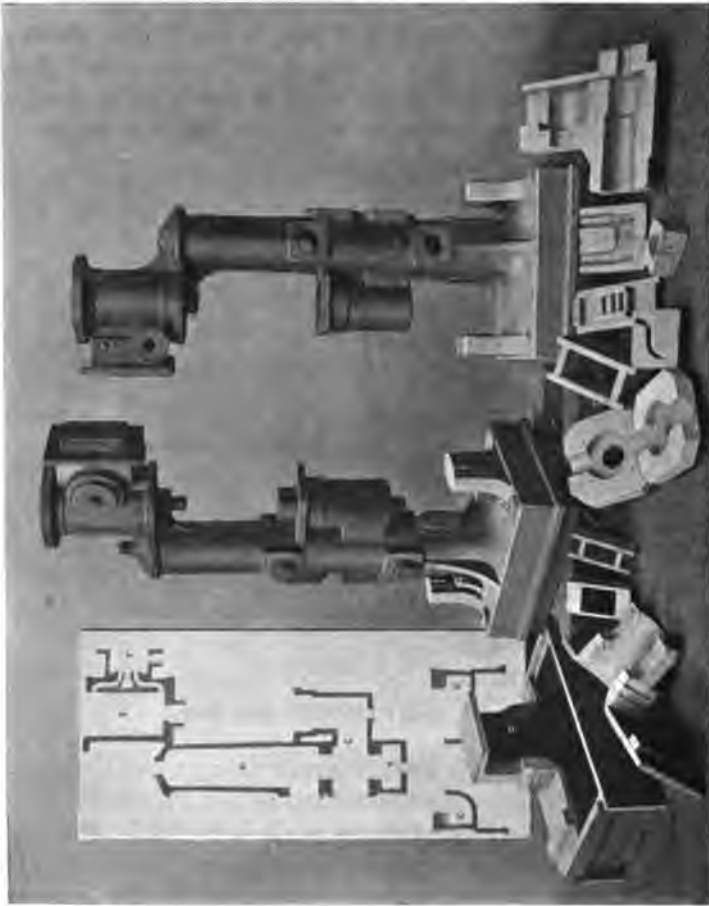

FIG. 182.—Main Casting, with Pattern and Core-Boxes, for Steam Pump.

steam chest core is readily discernible, as well as the core-box, which consists of a hollow rectangular frame, with a bottom piece carrying the prints for the steam and exhaust port cores. Projecting below the pattern may also be observed the large rectangular print of the core for taking out the hollow interior of the

base. This core is made in the box seen on the left, one half of the cover of which has been removed to exhibit the construction. One half of the core-box for the pump barrel and suction valve



FIG. 183.—Main Casting for Steam Pump. Cores and Core-Boxes.

chamber, with the connecting passage between them, is exposed on the extreme right of the view. The bogie with the cores just drawn from the stove is shown in Fig. 183, but it should be stated that in a few cases the core-boxes and loam boards have been placed

alongside for identification. Fig. 184 is a photograph of the mould, with the top box lifted showing the pattern "bedded in" the



FIG. 184.—Main Casting for Steam Pump. Pattern bedded in Foundry Floor.

foundry floor. In Fig. 185 the pattern has been withdrawn, and the cores placed in position, and Fig. 186 shows the mould closed and weighted, with pouring basin, risers, etc., ready for casting.

The mould for the *back standard* of an inverted vertical engine is shown in the photograph, Fig. 187. The pattern and core-box



FIG. 185.—Main Casting for Steam Pump. Mould with Cores in Position.

are seen reared up on the left. The latter is open-topped, to allow of the surface of the core being strickled off level with the upper edges of the box. The mould is seen with the core in

position, and the form of the parting, which follows the rake of the forked portion, should be noticed. The core is slung from the



FIG. 186.—Main Casting for Steam Pump. Mould Closed and Weighted ready for Pouring.

crane by three eyebolts sunk below the surface in small cavities, which are finally filled up level. The casting is poured simultaneously at two gates, which may be seen coming through the

top box just inside the fork. For each gate a well is provided in the lower part of the mould, communicating by three "sprues"



FIG. 187.—Back Standard for Inverted Vertical Engine. Mould with Cores in Position.

with the adjoining leg. This method is usually adopted if the metal is relatively very thin.

Methods of Reducing Cost of Pattern-making.—Use of Skeleton Patterns.—Many objects of simple form may be moulded

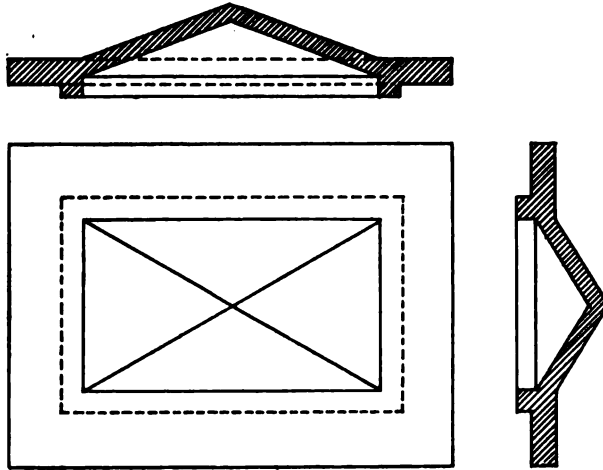

FIG. 188.—Sections and Plan of Domed Cover.

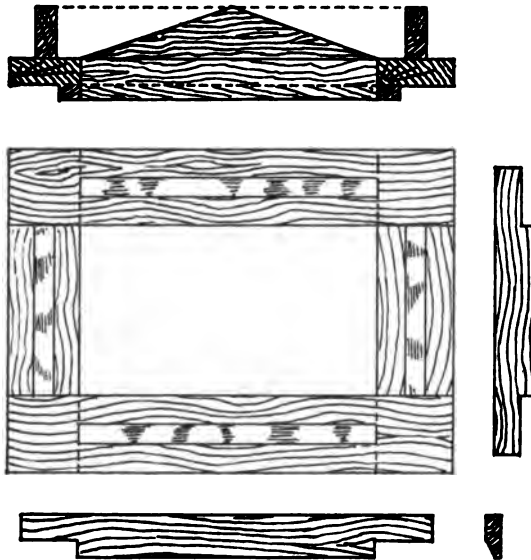

FIG. 189.—Skeleton Pattern for Domed Cover.

from a skeleton pattern resembling a mere outline framework, to which are fixed guiding surfaces for the "strickle" or chamfered-edged board used for taking out the intervening spaces. Inter-

secting surfaces, such for instance as those occurring in the domed cover, Fig. 188, may be very conveniently moulded in this way. The pattern consists of a simple frame jointed at the corners, and corresponding in size to the outer flange of the cover, Fig. 189. Upon this are fixed four guiding pieces for the strickle, two at the sides of the same shape as the outside of the longitudinal section, and two at the ends cut to the outside of the cross section. The pattern is embedded in sand, which is rammed up inside the frame to the form of the cover as nearly as can be judged, the exact shape being finally given by passing the strickle first over one pair of guides and then over the other. The guides, which are made easily removable for the purpose, are then taken off, and a pattern remains, partly of wood and partly of sand, upon which the top box may be rammed up, the method being known as "*reverse moulding*." After lifting off the top box, the guides are replaced, and the thickness of metal in the casting is scraped off the bottom part of the mould by means of a strickle let down and shouldered at the ends to the required amount. This method may be still more readily applied in the case of objects of circular form, which may be "swept up" either in greensand or loam, as may be most suitable. The striking board or strickle is attached to a revolving arm fixed upon an upright spindle, or "striking bar," which rotates in a footstep bearing or socket embedded in the sand, Fig. 190. In work of large size, the upper end of the bar may be supported by means of a bracket or "horse," projecting from the wall (see Fig. 201). The following simple example of sweeping up a dished cover in greensand will serve to explain the process. A pit is dug in the foundry floor and a coke bed extending over the full extent of the mould is laid down, the socket or spindle holder being embedded in it. At first, coarse, and upon that fine, sand is rammed down upon the coke bed, which is vented by means of haybands or pipes leading diagonally to the bed joint, Fig. 191 *a*. Upon this, a bed of sand is rammed hard, about level with the foundry floor. The spindle is then inserted in its socket, and the strickle attached to the rotating arm. Fine sand is then rammed down hard, until by revolving the strickle, an exact and very dense "reverse mould" is struck up, Fig. 191, *a*. This is covered with parting sand, and upon it the top box, or cope, is "gaggered," rammed, and vented, exactly as upon a wooden

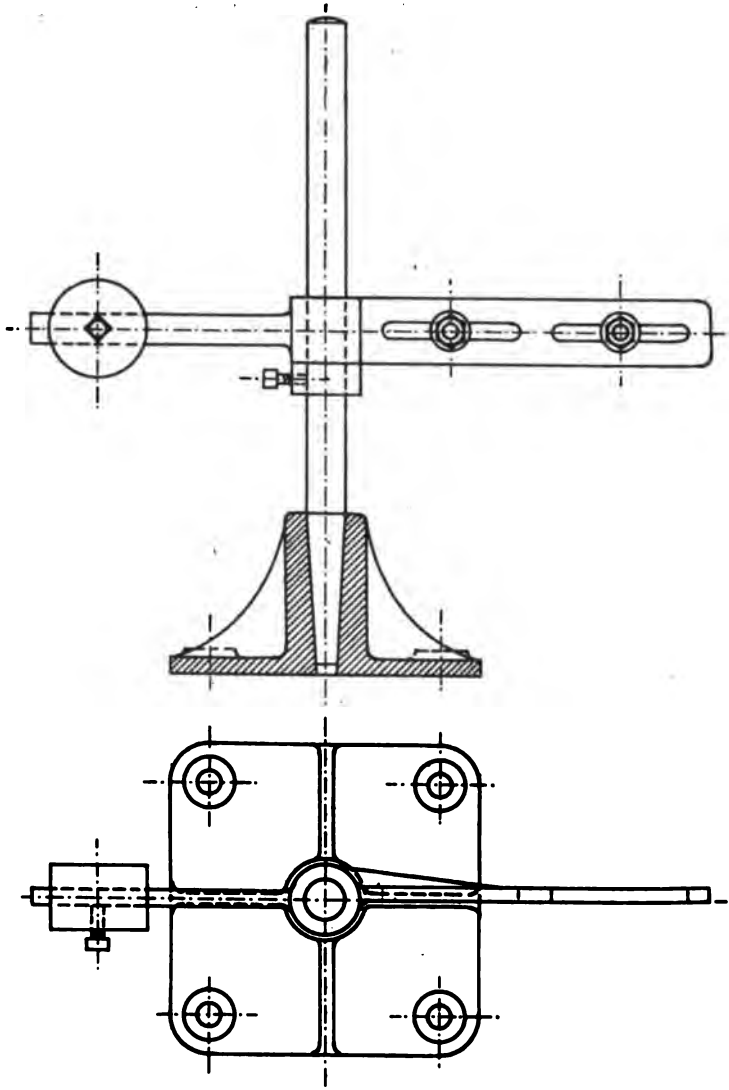

FIG. 190.—Striking Bar and Footstep for Loam, etc., Moulding.

pattern, Fig. 191, *b*. The proper position of the box is determined by iron stakes driven into the foundry floor, so that it may be lifted off, and turned over for mending and finishing in the usual way. To produce the lower half of the mould, the hard-rammed bed,

which is really a sand pattern, is dug out and remade exactly as when bedding in. The "bottom strickle," which penetrates to a depth below the surface equal to the thickness of metal in the

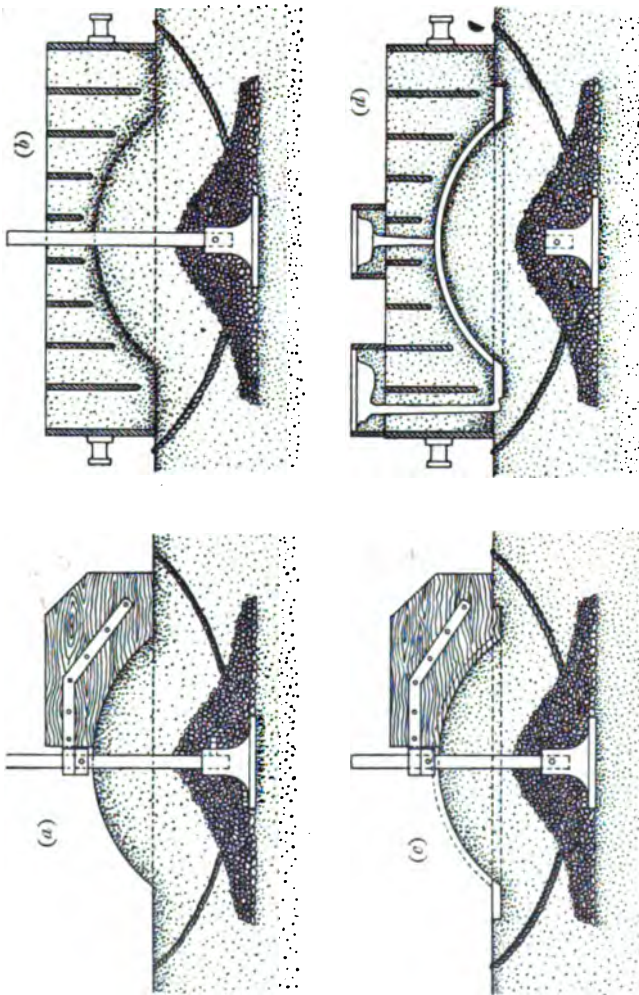

FIG. 191.—Moulding Dished Cover in Greensand.

cover, is then attached and is swept round and at the same time the sand added to the upper surface is pressed by hand, and lightly rammed, until the correct form is obtained, Fig. 191, c. The spindle is then removed, the hole stopped, and the mould

well vented, and finished off as already described, Fig. 191, *d*. The rim of a *fly-wheel* or *rope pulley* is generally struck up in green-

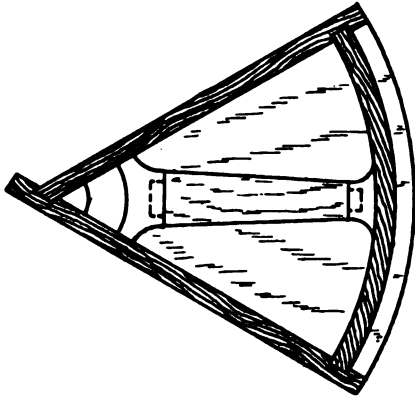
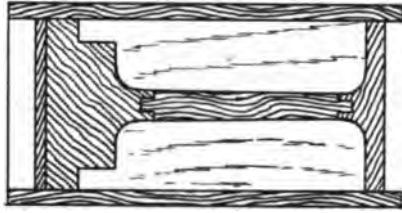

FIG. 192.—Core-Box for Arms of Pulley.

sand or loam, the arms and boss being formed in sector cores built into the mould. The core-box is shown in Fig. 192, and it will be seen that the angle between the radial sides = $360 \div$ number of arms in the wheel. The top and sides of the box are loose, and the pattern for the arm is doweled at each end. When the core has been rammed up, the sides are unscrewed and the core taken away, leaving the arm to be knocked out from the small end. The required number of cores are made, dried, blackwashed, and built into the mould, as

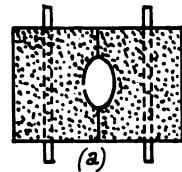
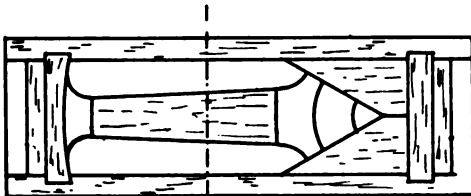

FIG. 193.—Core-Box for Arms of Wheel or Pulley.

shown in Fig. 194. The size of these arm cores may be reduced in the case of heavy wheels or pulleys by making the box rectangular, as in Fig. 193. The core in this case is made in

halves, jointed together horizontally, Fig. 193, *a*. A grid provided with projections which fit into notches cut in the upper edges of the core-box is embedded in each half to give the necessary strength to the core. When these rectangular cores have been placed in the mould, the triangular spaces remaining are filled in by ramming up sand between the cores against a "sweep," as shown on the left in plan, Fig. 194. This method is especially suitable for moulding wide pulleys with a double

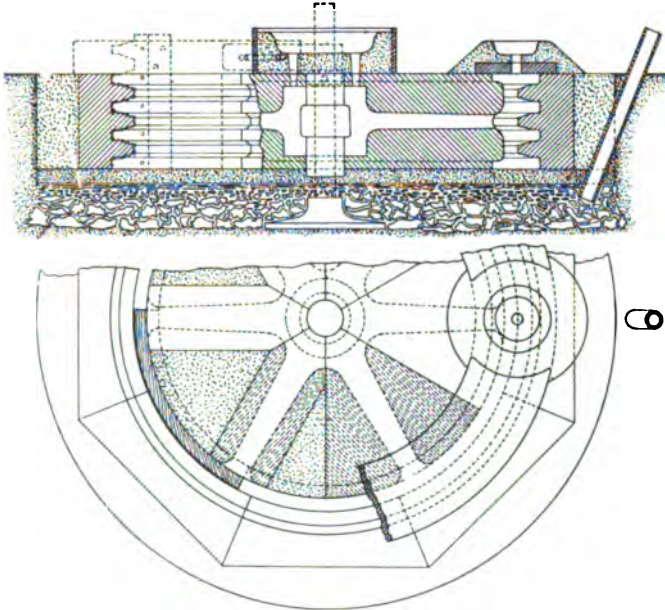

FIG. 194.—Complete Mould for Rope Pulley.

set of arms. Here the outside of the rim is formed in segments in the box, Fig. 195, or is swept up in loam carried upon an iron ring fitted with lifting bolts. The top of the mould is also struck up in loam carried upon a circular cast iron plate.

Loam Moulding.—Loam is a mixture of sand and clay ground up to the proper consistency in a sand mill. Various substances known as "openers," such as horse-dung, cowhair, and sawdust, are added to increase the porosity, and give the necessary bond. It is used in a moist condition like mortar, the mould being subsequently dried or baked. Loam moulding is carried out in two distinct ways. According to the *first method*, in preparing the

mould for any hollow object, *three parts are formed in succession, viz.:* (1) The *core* corresponding in shape to the inside of the casting; (2) the *loam pattern*, produced by adding the *thickness-piece* to the core, and which therefore possesses the same form as the exterior of the casting; and (3) the *cope*, which is constructed upon the thickness-piece, and which contains pouring gate, riser, etc. The method of moulding a *large hemispherical pan* may be taken as a good example of this process, Fig. 196. A circular base of brickwork is first built up, with a cylindrical cavity in the centre, from which a number of passages run

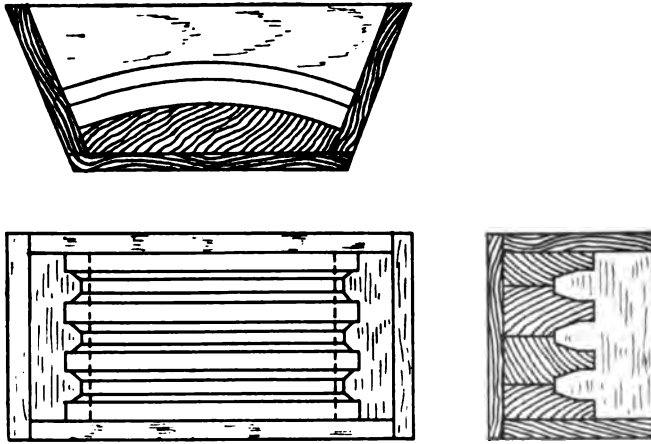

FIG. 195.—Core-Box for Rim of Rope Pulley.

radially to admit the air when drying the core. The base is covered with loam, which is swept up to a level surface or bed, A, by means of a straight-edged loam board, and is then dried. The body of the core, B, is next built up of brickwork, the bricks breaking joint in successive courses, with a thick layer of coarse loam at each joint. The spaces between the bricks ensure the necessary venting, which may be still further provided for by filling in cinders. A coating of loam is now laid upon the brickwork, and swept to the shape of the interior of the casting by the core board C, the lower end of which is guided upon the bed joint of loam. The core is dried by lighting a fire inside, and when dry, is blackwashed, and then thickened, a layer of loam being swept to the external shape of the casting by using the

thickness board, D (shown dotted). The "thickness" is similarly dried and blackened, and the cope then built directly upon it, a strong cast iron plate or cope ring serving as a support, by means of which it may be lifted. Usually three or four lugs are cast on the plate, which is thus suspended by slings from the cross piece of the crane (see Fig. 201). The cope, E, Fig. 197, consists of a loam face backed by brickwork, and strengthened when necessary by introducing iron rods, rings, or plates. When dry, the cope is lifted to allow the thickness to be parted and removed, and both cope and pattern are thoroughly dried, smoothed down, and black-washed before putting together again. This is facilitated by the conical form of the joint at J, which enables the

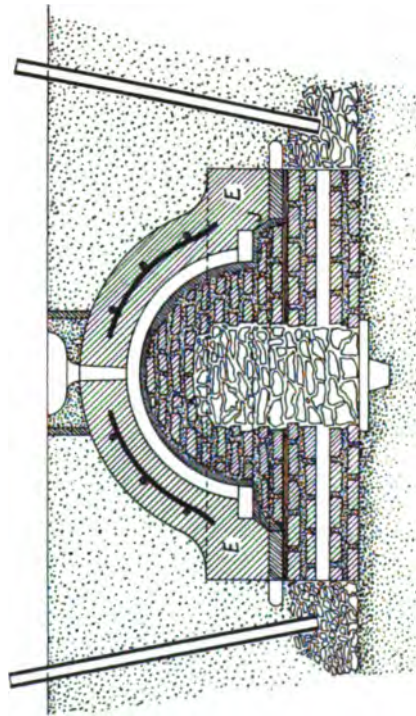

FIG. 197.

Moulding Hemispherical Pan in Loam.

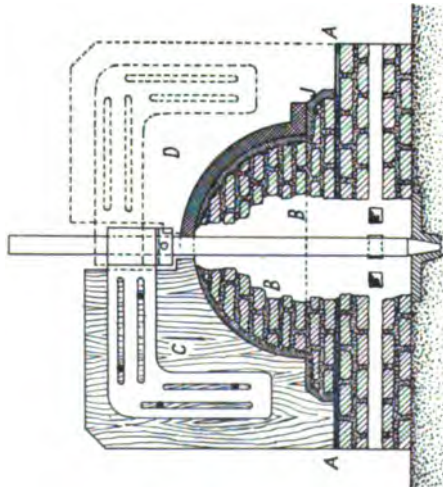
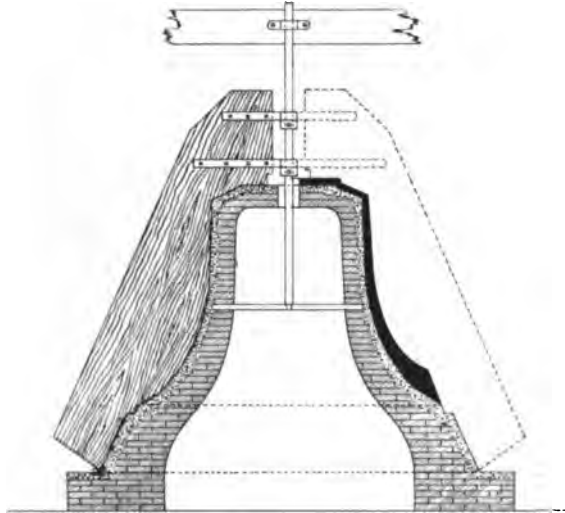
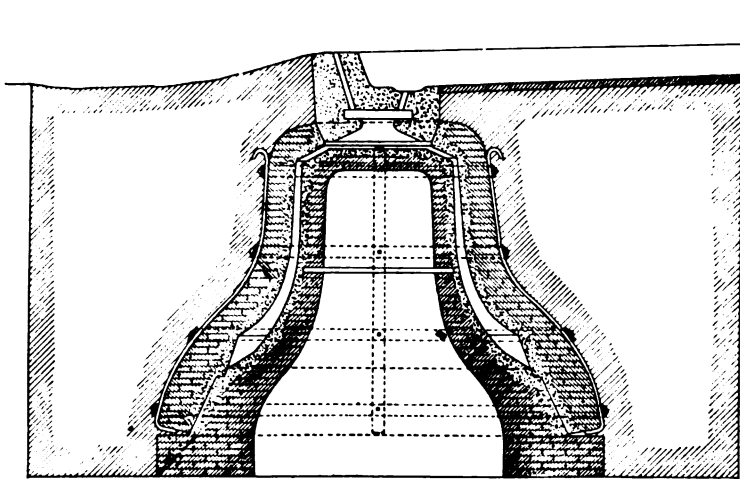

FIG. 196.

FIG. 198.



Striking up Core and Thickening Piece for Large Bell.



Complete Mould for Large Bell.

cope to be lowered into a perfectly central position. A *bell of large size* is moulded in a very similar manner, as will be apparent from Fig. 198. As a rule, the mould is formed in a pit, and when complete, is well rammed with sand round all sides.

According to the *second system of loam moulding*, the *core and the cope are built separately*, no thicknessing being necessary. Bells of ordinary size are moulded in this way. The method of working is clearly explained by reference to the photographs, Figs. 199 and 200, which were specially taken for the author by Messrs. Charles Carr, Ltd., the well-known bell-founders, of Smethwick, near



FIG. 199.—Striking up Core for Bell.

Birmingham. Fig. 199 shows the operation of striking up the core to the shape of the interior of the bell, and the cope containing the external form is seen in Fig. 200.

As a rule, the object to be moulded must be of such a shape as will permit of the core being lowered into position inside the cope, a "top plate" being required to close the mould. The example given is that of a short *flanged cylinder* of large diameter, Fig. 201, for which the ring body is built up of brickwork, either

on a brickwork bed as before, or on a cast-iron loam plate as at (a), the interior coating of loam being swept up by the board shown on the left. The core is also carried on a plate provided with lifting rods, and is swept up by the board shown at (b). The lower portion of both parts is of a conical form O, known as the "check," which ensures exact centering of the core when



FIG. 200.—Cope for Bell.

lowered into position. The loam plates have "prods" cast on both sides, to hold a layer of loam which is swept up and dried, so that the face is exactly square with the axis of the cylinder. The core is thus made to stand truly perpendicular in the mould.

A large steam cylinder is generally moulded in loam, the body being swept up as just described. As a convenience in moulding, the steam chest is cast separately, and afterwards bolted on in place. The port face, with steam and exhaust ports, may then be

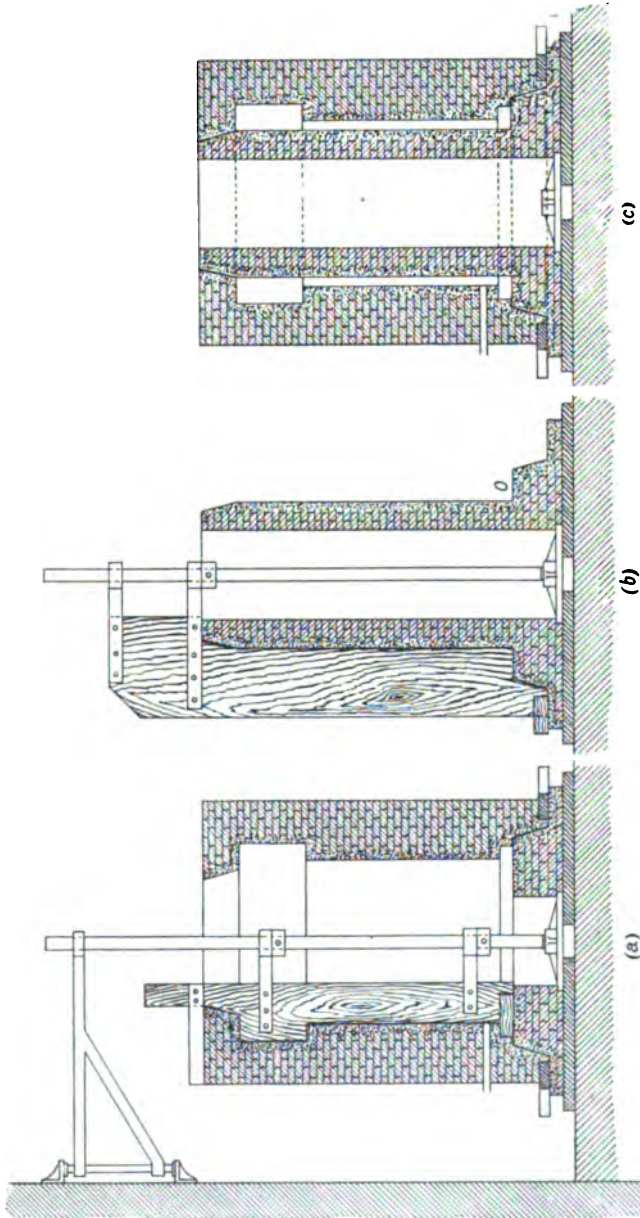

FIG. 201.—Moulding Short Flanged Cylinder in Loam.

moulded with the aid of patterns and core-boxes, in the usual way. The mould is built up on a loam plate *a*, Fig. 202, the socket for the striking bar being embedded in the floor, and the bar supported at its upper end by a suitable bracket. A thin layer of loam is spread upon the plate, and on this, brickwork to form the base is built up to the level of the bottom flange of the cylinder. The conical portion or check at *o*, is left as previously described, the finished shape being given by the loam board *b*. The latter is next removed, and the base, after

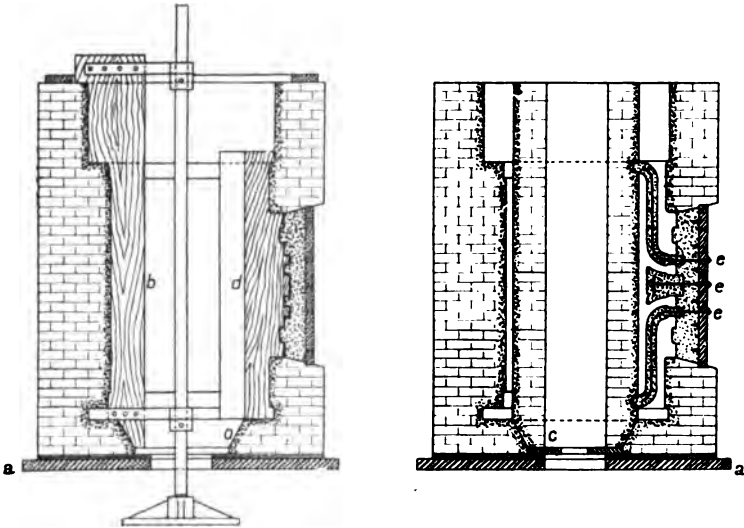

FIG. 202.—Moulding a Large Steam Engine Cylinder.

drying by means of an open coke fire, is coated with black-wash. An iron ring, coated with loam, is then placed upon the levelled surface of the base, and upon it the mould is built of common bricks coated with loam, swept to shape by a loam board. The pattern for the port face, *d*, is fixed in its proper position, and is embedded in about $1\frac{1}{2}$ inches thickness of loam, which may be increased at corners and projections, venting being effected by inserting wax wire in suitable positions. The flanges to which the steam chest is bolted must be left loose on the pattern, and are withdrawn subsequently. After removing pattern, the loam board is used to strike up the interior, two thicknesses of loam being put on. The first layer is of coarse loam about

1 inch thick, laid on by hand, and then dried. The final coat is much thinner and finer, and is worked to a smooth surface by the sharp edge of the board. When completed, the external mould is lifted off the base by the crane, and removed to the stove for drying. The striking bar is again erected in place, and by means of the core board, the bricked-up core is completed, commencing at the check on an iron ring, *c*, coated with loam. The steam and exhaust port cores are constructed on grids, which are held in place by screws, *e*, passing through the plate or door on the

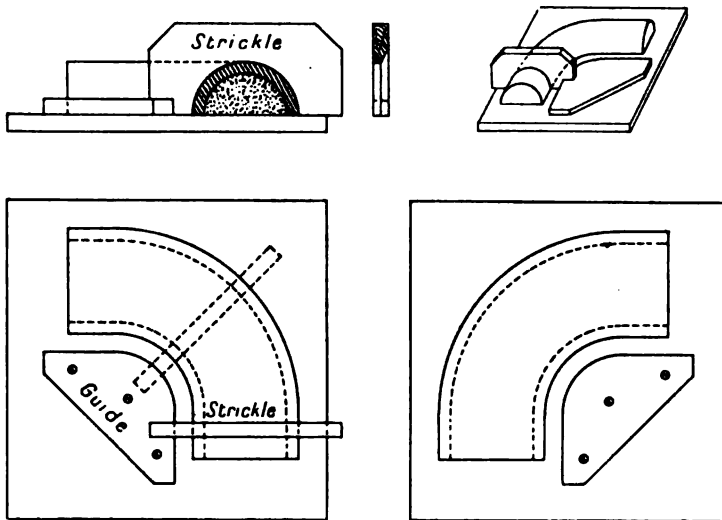

FIG. 203.—Moulding in Loam with Guide and Strickle.

outside of the mould. The ends of the S-shaped steam port cores are drawn back from the main core until the various parts of the mould have been adjusted in position. They are then pressed into place, and securely held by chaplet nails. When closed, the entire mould is placed in the casting pit, and sand rammed round it, to resist the pressure due to the liquid metal. The pouring basin is arranged in the sand above, the gate being made to enter the mould well down, to introduce the metal without shock. The interior of the core is best filled with cinders, to reduce risk of explosion due to accumulation of gas.

Moulding in Loam by means of Guide Iron.—Cores of circular

section and of curved or irregular form, are frequently made in halves by means of a strickle which is carried round a guide of the required shape fixed on a board, Fig. 203. The two halves are afterwards jointed and cemented together. By carrying the same

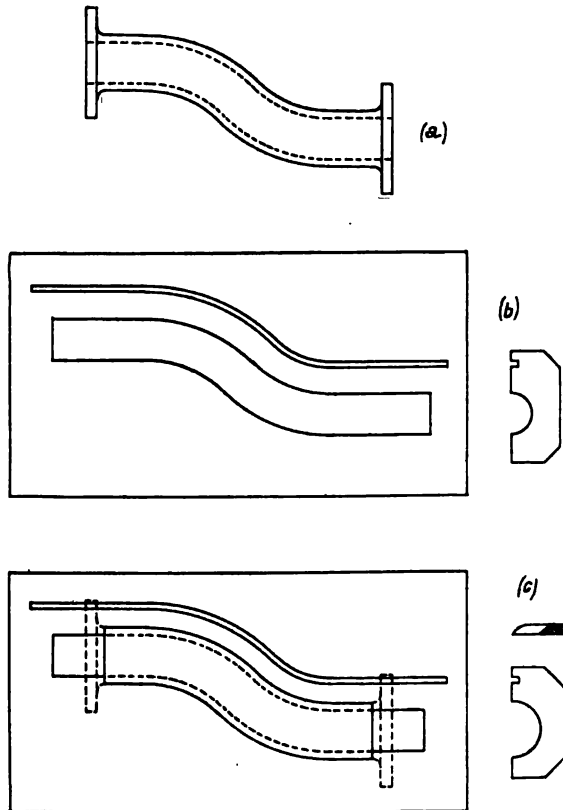

FIG. 204.—Moulding Bent Pipe in Loam.

principle a little further, a *bend* of any form for *cast iron pipe*, Fig. 204, *a*, may be worked in loam entirely without patterns. The section of the pipe is set out on a board, and a piece of $\frac{1}{2}$ -inch square iron is bent by the smith to a shape parallel to the centre line of the pipe, and at some little distance beyond its maximum diameter. This "guide iron," as it is termed, is fixed down upon the board in its true position, as shown in Fig. 204, *b*. Two

templates or strickles, one corresponding to the external, and the other to the internal, diameter of the pipe, are made by the pattern-maker, the edge of the semi-circle being chamfered as shown in section. A notch or "check," is cut in the corner of the strickle, by means of which it is carried round the guide iron exactly at the correct distance from it, and as nearly as possible at right angles to the centre line of the pipe. Using the core strickle in this way, a semicircular mass of loam is struck

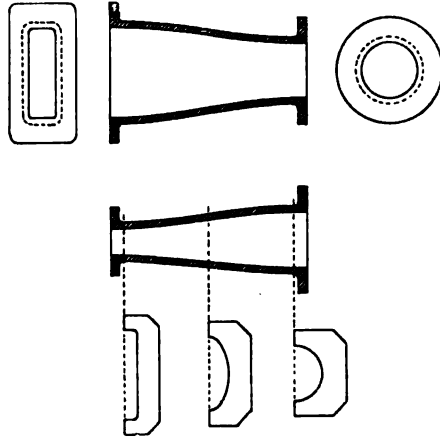

FIG. 205.—Moulding Pipe of Special Form in Loam.

up on a suitable core iron, and should spigot and faucet, or other special form of ends, be required, they are moulded from wooden patterns, or more correctly speaking, in core-boxes. For flanges, wooden patterns in halves are employed, as shown in dotted lines in the figure, and are held in place on the loam by means of nails. The guide iron is then reversed, and a second half core of the opposite hand is struck up. Without detaching from the plate, both halves are dried in the stove, and after blacking, are "thickened" by using the pattern strickle with the same guide iron as before, Fig. 204, c. Both are again dried, and are then removed from their respective plates, and cemented together to form the loam pattern. This is moulded in the ordinary way, after which the thickness piece is stripped off, leaving the core ready for the mould. It will be readily understood that the method is not limited to objects of circular section, but may be applied even where a change of section occurs, as, for instance, from circular to rectangular. Taking, for example, a *pipe of special form* shown in Fig. 205, the core is first struck up, using a strickle of semi-circular shape for one end, and rectangular for the other. The rough core, after drying, is worked down by a rasp to the gradually tapering form required, and is finished with

pumice stone or glass paper. After treating with blackwash, strips of the same thickness as the metal are fixed upon the core,

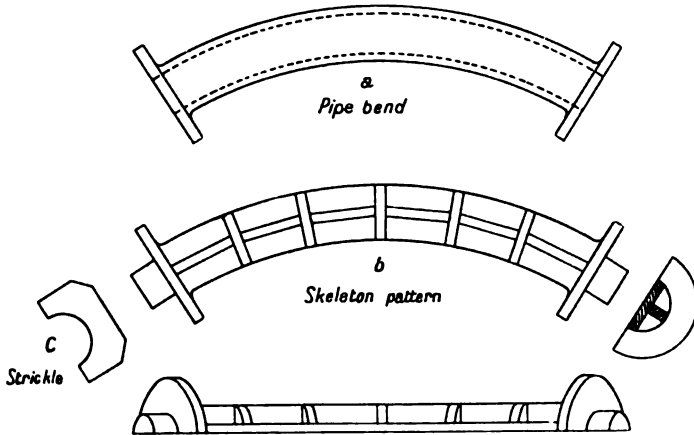

FIG. 206.—Skeleton Pattern for Pipe Bend.

and the intervening spaces filled up level with loam, which is then dried. The strips are next taken off and replaced by loam, which is dried, and the pattern completed as before.

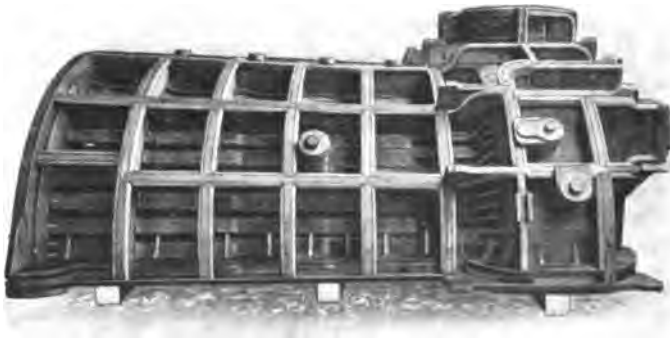

FIG. 207.—Pattern for High-pressure Turbine of Cunard R.M.S. "Lusitania."

Skeleton Patterns.—It frequently happens that a single casting of unusual size or form, such as a *pipe bend*, is required at

short notice. To avoid the expense of making a complete pattern, and also to save time, a " skeleton " pattern, of which an example is given in Fig. 206, is constructed. This consists simply of a



FIG. 208.—Cylinder Patterns for Inverted Vertical Marine Engine.

piece of flat board cut to the outline of the pipe, a half flange with print attached, being turned separately, and screwed on at each end. A number of half-round pieces, corresponding to the external diameter of the pipe, are fixed upon the board at intervals, and are held firmly in place by inserting longitudinal

stiffening pieces between them. The moulder first proceeds to fill up the intervening spaces with sand, which is rammed in hard, and strickled off to the edges of the skeleton frame. From the combination pattern of timber and sand, the object is moulded in the usual way. For some interesting examples of work of this character on a very large scale, the author is indebted to Messrs. E. M. Brown & Co., patternmakers, of Huddersfield. Fig. 207 is from a photograph of the pattern for the top half of the casing of the high-pressure turbine for the Cunard R.M.S. "Lusitania." This pattern, which was made for Messrs. John Brown & Co., Ltd., of Clydebank, measures 28 feet in length by 11 feet 6 inches in height. Fig. 208 shows the patterns for the high pressure and intermediate cylinders of a large inverted vertical marine engine of the reciprocating type.

CHAPTER XXIII.

CHILL CASTING.

It has been shown that the hardness of cast iron depends upon the condition of the carbon contained in it. In the very hard white variety the carbon is almost entirely in the combined form, whereas in the soft grey irons, by far the greater portion of the carbon present is in the free or graphitic state. When cast iron is cooled very rapidly, the crystals of graphite have not time to separate, and the carbon remains combined with the iron. This may be effected by casting the iron in a metal mould, the result being known as "chilling." The more rapid the rate of cooling the whiter will be the iron, or the greater the depth of chill. A special grade of iron, low in silicon content, is necessary to secure the best result, which is also to a great extent influenced by the thickness of the metallic mould, and the temperature of pouring. Hence, the depth of chill below the surface may vary from $\frac{1}{2}$ inch to 1 inch or even more, the rest of the metal remaining soft and grey. Advantage is taken of this fact in casting rolls for rolling mills, shoes for battery stamps and other parts of crushing and grinding machinery, tramcar wheels, ploughshares, etc., where an extremely hard surface is required with an interior of softer and tougher metal. Those parts which are to remain soft may be cast in green or dry sand in the usual way, the chill being arranged to take the place of one of the boxes forming the mould, or in some cases the wooden pattern may be placed inside the chill, and the two rammed up together in the mould. *Car wheels*, which are chilled on the tread, are moulded in a three-part box, the "middle" of which is the chill, Fig. 209. The boxes are of circular form, and with the chill, are provided with pins and lugs as usual. The chill ring is bored out to a smooth surface, and is turned upon both faces. Before casting, it should be heated to drive off moisture, and the internal surface thickly coated with plumbago to prevent risk of fusion by the molten metal. The chilled part of the casting sets

very quickly, and the wheel, while still red-hot, is transferred from the mould to an annealing furnace, where it remains three or four days. Very slow cooling must be resorted to, in order to reduce contraction stresses which are liable to be set up in the unchilled part. The manufacture of chilled car wheels has been very extensively developed in America, where they are employed not only for tramway vehicles, but also for goods wagons, railway carriages, and even locomotive engines and tenders. In this country, steel castings are preferred, even for such a purpose as the wheels of colliery tubs. Fig. 210 shows the complete mould for pouring. This arrangement has been adopted by many firms

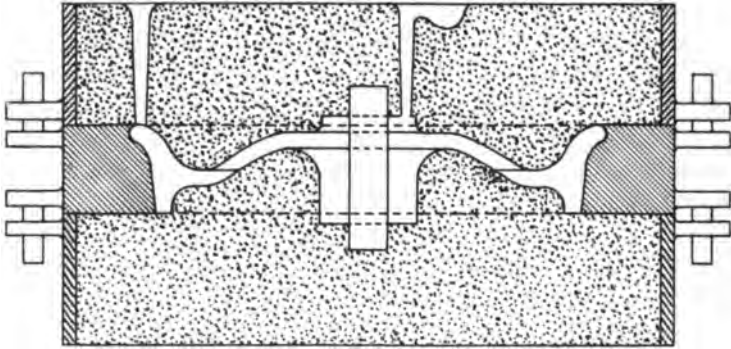

FIG. 209.—Mould for Chilled Car Wheel.

in the States, which specialise entirely on this class of work, and it is the general practice to cast the wheel "flange down." The mould consists of four parts: Cope A, chill B, drag C, and "bottom board" D, all of circular form, the latter a perforated cast iron plate, shown in plan at (c). The cope, A, and the chill, B, are bolted together with four bolts, E, and two pins, F, enable the chill to be located in proper position on the drag, C. The chill is also provided with trunnions, G, for lifting (see plan). To take out the double plate portion, a ring core, H, is used, supported on three round feet, I, through which any gas may find its way, escaping by the perforated bottom plate. The same remark applies to the core, J, for the central boss. The ring core is prevented from rising by chaplets, K, the stems of which are placed in holes drilled in bosses cast on the cope for the purpose. The

mould is poured from a central basin or "dish," L, cast in a piece with the cope, radial bars connecting the dish with the outer rim, as seen in plan at (b). It is stated that a man and his helper can make per day twenty complete moulds as here shown.

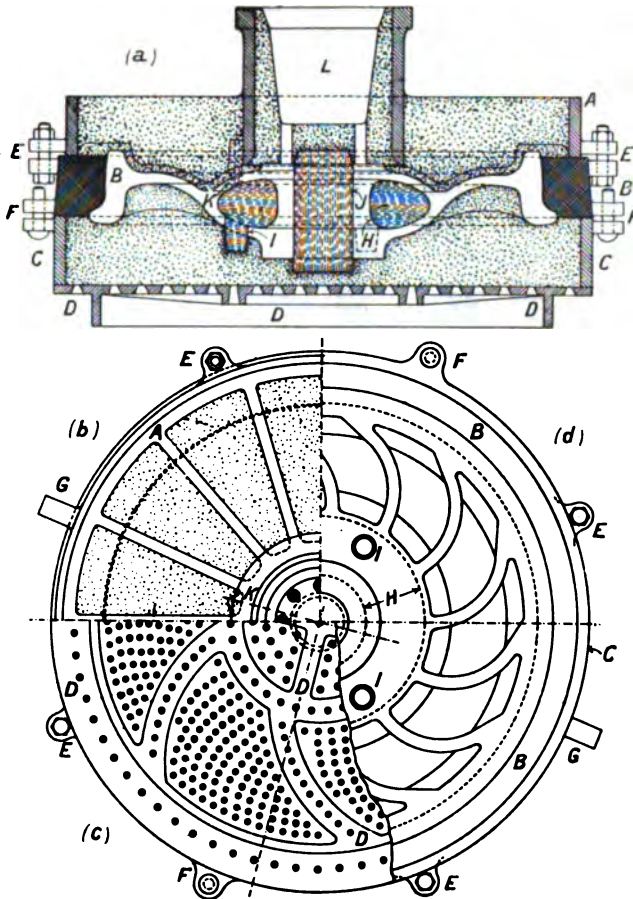

FIG. 210.—Mould for Chilled Car Wheel.

The casting of a *chilled roll* affords another example of the use of a composite mould of sand and cast iron, Fig. 211. Rolls are moulded vertically, with a head cast on the top into which scurf may rise, and of sufficient size to do duty as a feeder. In

addition to feeding by a rod, hot metal must be added from a hand ladle at intervals, to make good the loss due to shrinkage which takes place in the interior on cooling. The chill for the body of the roll consists of a thick cylinder, accurately bored out to size, and connected by bolts or pins to the top and bottom boxes. The necks and couplings at the ends of the roll, which have to transmit the whole of the power, are left as strong and tough as possible, and are therefore cast in sand, moulded from

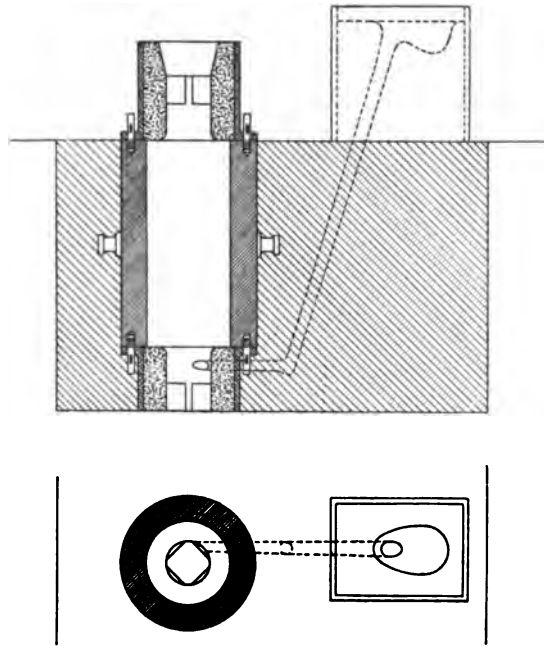

FIG. 211.—Mould for Chilled Roll.

a pattern. The complete mould is sunk inside a pit, and sand well rammed round it. The gate, which must be formed outside the mould, is introduced through the bottom box in a tangential direction, to give a rotary motion to the entering metal. The centrifugal action thus induced throws the heavy metal to the outside, the scum or scurf rising quietly at the centre, which is an essential feature to securing a perfectly clean face of the roll.

Core Chills are used in casting bushes which have to resist wear, as for instance, the naves for ordinary cart wheels, etc.

Here the chill consists of an iron pin, which is supported in iron prints fitted on the pattern and left behind in the sand when the pattern is withdrawn. The core chill is thus centred very truly, which is important where the hole cannot afterwards be bored out. The core chill must be knocked out before the casting has had time to shrink tightly upon it.

The Use of Chills as "denseners."—As ordinarily understood, the function of a chill is to produce a hard white iron on the surface of an otherwise soft casting. Recently, however, the term chill has been used in an entirely different sense, which is somewhat unfortunate, and liable to lead to confusion. It has been shown that castings in the form of wheels or pulleys are liable to give trouble on account of not being sound in the boss. This is due to the slow rate of cooling of the thick boss, and at its junction with the comparatively thin arm, porosity or sponginess frequently results in consequence. The use of the feeding rod is commonly resorted to as a cure for this evil (see Fig. 146), but it is at best an imperfect remedy. A chill or cooler placed in the centre of the core is likely to be much more effective than the feeding rod. It should be remembered that the slow rate of cooling which occurs at the thick sections of a casting is sure to result in an open, porous and weak body of metal at those points. If a chill or cooler of the correct design and thickness can be applied to the thick section, and thereby accelerate solidification, all danger of porosity or sponginess will be eliminated. This is due to the fact that the carbon has less time to separate out in the form of graphite, and is therefore retained more in the combined condition, which causes the metal to be closer and stronger. When the casting has solidified, the object of the chill has been accomplished, and it may be removed to avoid chilling in the ordinary meaning of the term. There can be no doubt that, intelligently applied, this system of artificially accelerating the solidification of the thick portions of a casting must constitute a valuable aid to foundry practice.

CHAPTER XXIV.

THE FOUNDRY AND ITS EQUIPMENT.

THE ideal lay-out of a foundry depends to a great extent upon the nature of the work to be done, but certain broad principles must always be taken into consideration. The building is usually rectangular in plan, and although divided into bays for structural reasons and for the accommodation of overhead travelling cranes, the whole space should be left free and unobstructed, internal walls being avoided. The number and size of spans is governed largely by the primary division into heavy and light work which is observed in almost all foundries, heavy work being confined to the main bay served by an overhead traveller, the smaller bay or bays, provided with runways, or light jib cranes, being reserved for light work. The sections for drysand work, core-making and loam, each confined to itself, must be located in the neighbourhood of the drying stoves, and kept separate from the space allotted to greensand moulding. It is also desirable that special work, plate moulding, and machine moulding, should each be carried on as a distinct department. The cupolas are best placed centrally, at the side rather than at the end, the charging platform with hoist, iron store, etc., being kept outside the foundry proper. Adjoining the cupolas must be placed the engine-room, containing also the blower or fan, and any other machinery to be driven by the engine, such as the sand mixer, pan mill, emery wheels, etc., should be arranged in close proximity. This fixes the position of the dressing or fettling shop, in which the castings are cleaned and brushed free of sand, cores removed, runners and risers cut off, etc. The boiler should be as close to the engine as possible, and may be placed most conveniently on the opposite side of the cupolas, followed by the drying stoves, which may be made to utilise the waste heat from the boiler, or if separately fired, should discharge into the same chimney. Hence cupolas, engine and boiler houses, drying stoves, etc., are best ranged down one side under one roof, with

sheds for storage of raw material, coal, coke, pig iron, limestone and sand, built parallel to the rear, and so communicating with railway sidings that the contents of the wagons may be discharged direct where required. The stores, time office, foreman's office, workmen's lockers, and lavatories are situated near the entrance, partitioned off from the main building. In addition to cranes for dealing with heavier objects, too much attention cannot be given to the provision of lifting, etc., appliances of the handiest type to assist the men in their work. The foundry should be served throughout, and connected with the other parts of the works, by a light railway. It is most important that the building should

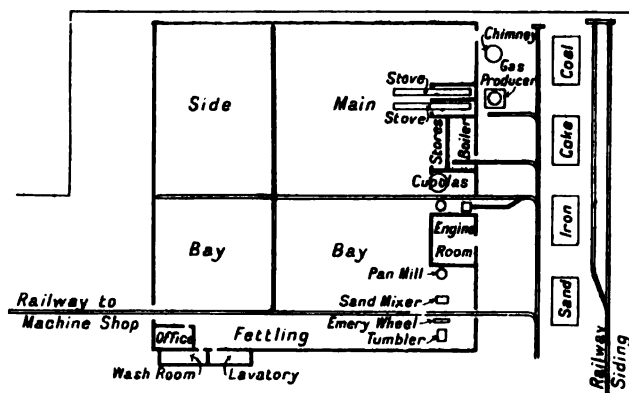

FIG. 212.—Plan of Typical Iron Foundry.

be well lighted, both by roof glazing, and by side windows in the walls. Thorough ventilation, with proper means for removing dust, smoke, and fumes, is now regarded as absolutely essential. These requirements have been well carried out in the plan shown in Fig. 212, which in recent years has been widely adopted. The photographs, Figs. 213 and 214, which represent the main and side bays respectively in the foundry of Messrs. Croft and Perkins, Ltd., engineers, Bradford, will serve to show the clear floor space, ample head room, and abundant lighting provided in the modern foundry.

The ironfoundry at the works of Messrs. G. & J. Weir, Ltd., Cathcart, Glasgow, Fig. 215, affords another example of up-to-date practice in the same direction. This foundry is designed for the rapid and economical production of light and medium-

weight iron castings, and every effort has been made to secure the rapid and efficient handling of both raw materials and finished castings. In each of the two bays hydraulic jib cranes



FIG. 213.—Main Bay of Foundry, at the Works of Messrs. Croft and Perkins, Ltd., Bradford.

are installed for the handling of boxes, etc., electric overhead cranes being provided for general transport. The foundry floor, measuring 300 ft. in length by 70 ft. in breadth, is laid entirely with concrete as being conducive to ease and tidiness in working.

One bay is devoted to general moulding, and the other bay to the operations of core-making, closing, and casting.

The Melting of Metals in the foundry is carried out in



FIG. 214.—Side Bay of Foundry, at the Works of Messrs. Croft and Perkins, Ltd., Bradford.

(1) an open bath, heated from below; (2) a crucible furnace; (3) a cupola; or (4) an air furnace. The first is suitable for metals of low melting point only, such as tin, zinc, and lead. The crucible furnace, though available for the highest temperatures, is the most costly in operation, and is rarely employed if

any other method can be adopted. Steel can be melted only in a crucible furnace, but the majority of steel castings are made immediately after tapping out the metal from the Siemens



FIG. 215.—Iron Foundry, at the Works of Messrs. G. & J. Weir, Ltd., Glasgow.

furnace, or the converter, no remelting being necessary. Brass and gun-metal must be melted in crucibles, or in an air furnace, to avoid contact of the metal with the fuel, as otherwise gases and impurities are liable to be absorbed by the molten metal from the waste products of combustion. The cupola is employed solely

for cast iron, and affords the only instance in which the fuel is burnt in contact with the metal. The air furnace is occasionally used for heavy castings or large quantities of cast iron, or of bronze. It may be said that in the iron foundry the cupola is almost invariably used, the air furnace rarely, and the crucible furnace never.

The Cupola consists essentially of a cylindrical casing of iron or steel plates lined with firebrick. An opening or charging door is provided near the top for the introduction of the pig iron and fuel, and at the bottom is the hearth, where the molten metal collects, and from which it is run out, or "tapped" into ladles. To produce the intense heat required, a sufficiently rapid combustion of the fuel is maintained by blowing in air under pressure through pipes or tuyeres, situated at some little distance above the hearth. The cupola most extensively used in this country is of the type introduced by Messrs. Thwaites Bros., Ltd., of Bradford, Fig. 216, the essential features of which are (a) the drop bottom, (b) the blast box arranged with two or more rows of tuyeres, and (c) the receiver for the collection of metal as it is melted. The cupola, Fig. 217, stands on a cast iron base plate, supported on four cast iron columns, and the bottom is closed by a hinged falling door, held in position by a long bolt sliding through lugs. As compared with the older form of solid bottom and raking out hole, the drop bottom possesses several important advantages. The cupola can be emptied at the end of the day's operations with the greatest facility, avoiding the heavy work of raking out and frequent quenching of coke, and the lining can be repaired with the greatest ease and with the least delay, as the cupola cools much more quickly due to the rapid current of air when the bottom has been dropped. With the older arrangement, the blast is usually introduced into the cupola by means of



FIG. 216.—Thwaites' Cupola.

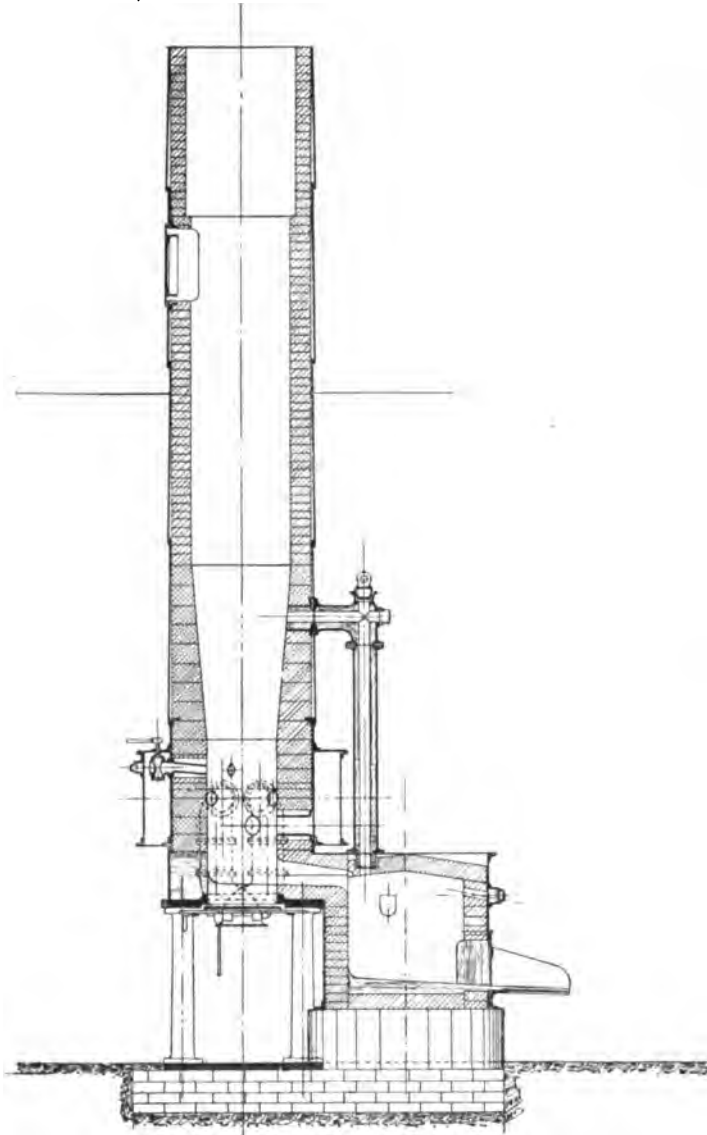

FIG. 217.—Section of Cupola with Receiver.

tuyeres connected to the blast main and passing directly through the firebrick lining. In Thwaites' cupola an air belt or blast-box

surrounding the hearth is employed, into which the blast main delivers, and from which the tuyeres, usually in three rows, lead into the furnace. This gives a much more even distribution of the blast than can be obtained by tuyeres alone. A small movable door, known as a sight-hole, is fitted in the belt opposite each tuyere, and is provided with a blue glass plate, so that the progress of the melting may be observed. A bar may also be introduced through the door to knock down any obstruction or "scaffolding" due to accumulation of slag, etc., which may collect. The blast enters the belt from the main through a breeches pipe, each branch of which is fitted with a valve, so that in case of necessity,—as, for instance, the occurrence of a scaffold,—the whole volume of the blast can be thrown on one side of the cupola by manipulating the valves. The third feature is the firebrick-lined cylindrical receiver into which the metal is delivered as fast as it comes down, until a quantity has been stored up equal to half the hourly melting capacity of the cupola. The plan commonly adopted when making heavy castings with one cupola of comparatively small size, is to melt one or two tons of metal in the usual way and run it into the ladle. A similar quantity is again allowed to collect in, say half-an-hour's time, and is also tapped into the same ladle as before, the surface of the metal being covered with a layer of charcoal powder to retain the heat and prevent oxidation. This may be repeated with one or more ladles until the required quantity has been obtained. It will be seen that the use of the receiver effects the same object in a much simpler manner. The tapping hole is thus always open, and a circulation of hot air is maintained through an upright ganister-lined pipe at the top to prevent any chilling of the metal.

Charging the Cupola.—After closing the drop bottom, the hearth, or sand bottom, of the cupola must be prepared by well ramming a layer, 6 inches thick, of sand from the foundry floor slightly moistened with loam wash. This is effected through the fettling door opposite the spout leading to the receiver. A wood fire is then kindled and covered with coke, air entering through the fettling door until combustion proceeds vigorously, when the door is made up and more coke added from above. When the cupola is thoroughly heated, alternate layers of pig iron and coke are put in through the charging door, and in about two hours' time, the blast is turned on, the cupola being kept quite full as

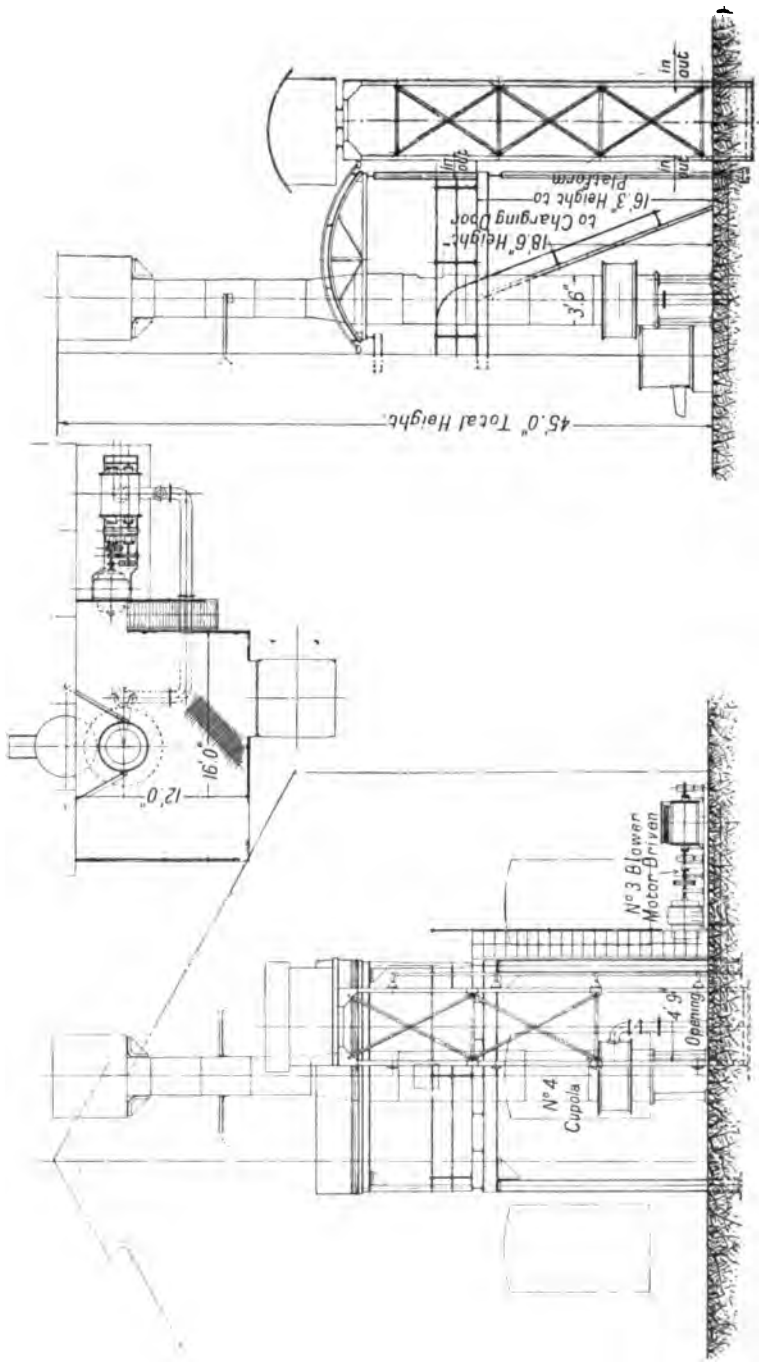

FIG. 218.—Charging Platform for Cupola.

the charge sinks. The materials should be weighed out in proper proportion, about $2\frac{1}{2}$ cwts. coke being required for each ton of iron melted. The materials are raised by means of a lift to the *stage or charging platform*, built to the rear of the cupola at a convenient distance below the charging hole. The platform should be of ample size to allow of storing all the pig and scrap iron, coke and limestone required for the charge, Fig. 218. From $\frac{1}{4}$ to $\frac{1}{2}$ cwt. of limestone for each ton of metal is also added to the charge, to act as a flux, forming with any iron oxide and the ash, etc., from the fuel a fusible slag, which floats upon the surface of the metal in the receiver, and is run off from time to time through the spout shown. At the bottom of the receiver is an opening giving access to the interior, and closed by the tapping door, in the lower edge of which is cut the tapping hole. During melting, this is closed by a stopper or plug of fireclay, which can be knocked out with a pricker bar when it is required to tap the metal into a ladle.

The Blast for the Cupola.—Much has been said and written concerning the *relative merits of the fan and the blower* for foundry purposes. In any case, the primary object is to move air against a resistance, and the essential difference between the fan and the blower consists in the method of creating pressure to overcome the resistance. In a fan of the centrifugal type, Fig. 219, velocity is imparted to the air in its passage from the central inlet to the outer circumference of the revolving wheel. This velocity is converted into pressure, with corresponding increase in density, within the fan case and its connections, and the pressure thus produced is therefore dependent upon the speed of revolution. At constant speed, the volume delivered and the power absorbed decrease as the resistance increases. Suppose the delivery orifice to be completely closed, thereby increasing the resistance to a maximum, and let the fan continue to revolve without change of speed, simply churning the air in the casing. The delivery then, of course, becomes zero, and the power required to run the fan is a minimum. With the "positive" type blower, on the other hand, the method of working is totally different. A certain volume of air enclosed between the revolving impellers and the casing is delivered four times each revolution against the resistance to be overcome. The air is thus compressed to a density proportional to the resistance, and the pressure is

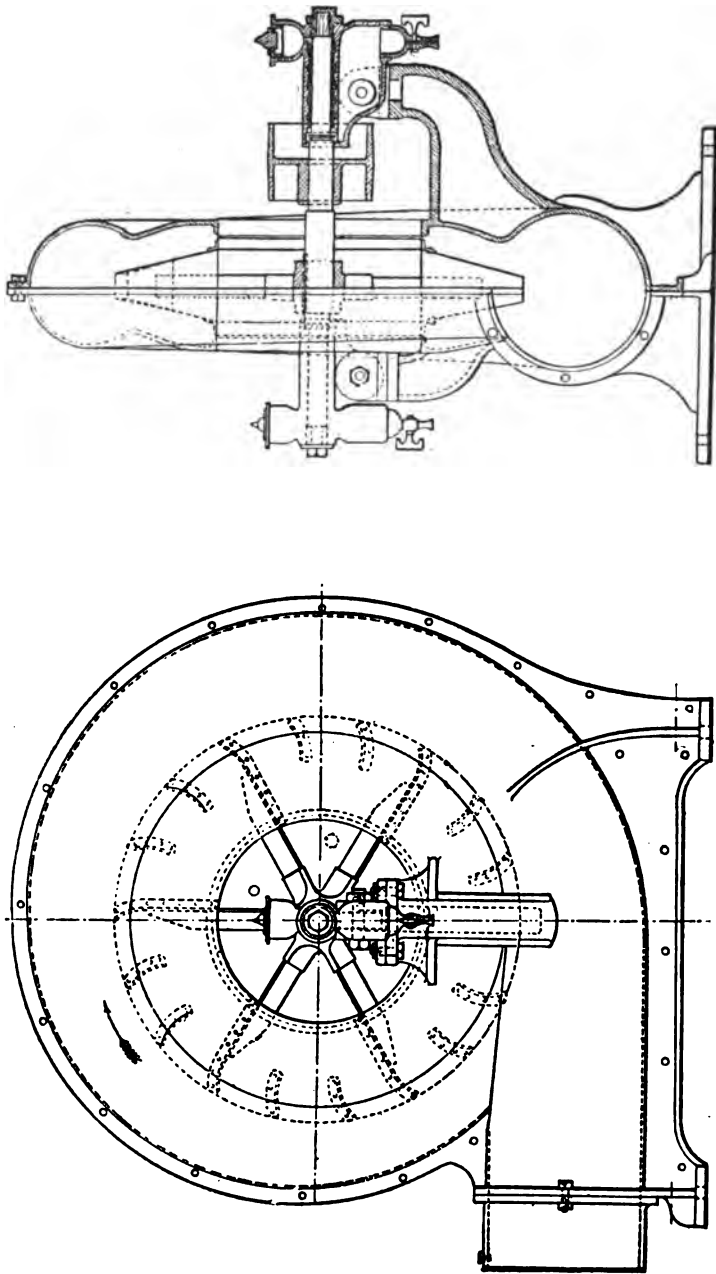

FIG. 219.—Centrifugal Type of Fan for Blowing Cupola.

increased in the same ratio. If the speed is constant, the delivery remains unchanged so long as discharge takes place, and the power expended increases with the resistance. Hence, if the delivery orifice be closed, the power expended is a maximum, and the air displaced is accounted for entirely by "slip."

Theory of the Fan.—The laws governing the movement of gases are the same as those which apply to liquids in motion. To produce a given velocity, v , a certain ideal head is necessary, and neglecting friction, the velocity of flow is the same as that which would be acquired by a body falling freely under the action of gravity through a distance equal to the head, h , or

$$v = \sqrt{2gh} \quad . \quad . \quad . \quad (1)$$

in which v = velocity in feet per second; h = head in feet; and g = acceleration due to gravity = 32.2 feet per second. The head, h , may readily be expressed in terms of pressure, p , and density, d . For instance, in the case of water it is well known that a cubic foot weighs 62.5 lbs., from which the density, or weight of a column of water 1 foot in height and having a base 1 square inch in area = $\frac{62.5}{144} = .434$ lb. Hence the head, or height of a column of water equivalent to the pressure of the atmosphere, or 14.7 lbs. per square inch is found to be $\frac{14.7}{.434} = 34$ feet, and, in general, it may be said that

$$p = hd, \quad \text{and} \quad h = \frac{p}{d} \quad . \quad . \quad . \quad (2)$$

In dealing with air, the pressure may be conveniently expressed in pounds per square foot, or more usually, in inches of water gauge (see Fig. 221). A cubic inch of water weighs $62.5 \div 1,728 = 0.036$ lb., and therefore a column of water 1 square foot in area and 1 inch high will weigh $144 \times 1 \times 0.036 = 5.2$ lbs. Hence,

Pressure in lbs. per square foot $\div 5.2 =$ inches of water gauge.

The density, d , is taken as the weight = 0.077 lb. per cubic foot of dry air at normal temperature and atmospheric pressure, and combining equations (1) and (2) we have

$$v = \sqrt{2g \frac{p}{d}} \quad . \quad . \quad . \quad (3)$$

The theoretical water gauge produced by a fan is proportional to the velocity of the outer circumference of the fan wheel, or as it is generally expressed, to the velocity of the blade tips. From equation (1) the head may be found by the formula

$$h = \frac{v^2}{2g}$$

The total weight of a column of air of height, h , and of 1 square foot in area = $0.077h$, from which the equivalent water gauge

$$= \frac{0.077h}{5.2} = 0.0148h.$$

Thus, suppose a fan has a diameter of 2 feet, and that its speed is 1,400 revolutions per minute. The velocity of blade tips is then

$$v = \frac{2 \times 3.14 \times 1,400}{60} = 146.6 \text{ feet per second,}$$

the head corresponding to which is,

$$h = \frac{146.6 \times 146.6}{2 \times 32.2} = 333.7 \text{ feet.}$$

The weight of a column of air 333.7 feet high and of 1 square foot area = $333.7 \times 0.077 = 25.69$ lbs., and the equivalent water gauge = $25.69 \div 5.2 = 4.94$ inches.

Under the conditions stated, the velocity at the circumference of the fan wheel, *i.e.*, of the fan tips, necessary to produce a given velocity of discharge through a properly shaped outlet, may be taken to be equal to the velocity, v , as found above. The volume therefore varies directly as the speed. But the formula also shows that the pressure produced by a given fan varies as the square of its speed, thus from (3)

$$p = \frac{dv^2}{2g} \quad \dots \dots (4)$$

The work done per second, W , is the product of the velocity of the air in feet per second = v , the pressure in lbs. per square foot = P , and the area in square feet = A , upon which the pressure is exerted, or

$$W = v PA \quad \dots \dots (5)$$

Making allowance for change of constants in calculating P, equation (4) may be written :—

$$P = \frac{Dv^3}{2g}$$

Substituting this value of P in (5) :

$$W = \frac{DAv^3}{2g}$$

From which the important result is obtained that the work done varies as the cube of the velocity, or, in other words, the horse-power required to drive the fan is proportional to the cube of the number of revolutions per minute, and may be written :—

$$\text{H.P.} = \frac{60 DA v^3}{64.4 \times 33,000} = \frac{DA v^3}{35,420}$$

Hence, if the speed of a fan be doubled, the volume is also doubled, the pressure is increased four times, and the horse-power required to drive the fan will be eight times greater. The great increase in power which is required for only a small increase in the speed of a fan is thus explained, and the serious loss of efficiency which results from the use of a fan not properly proportioned to its work is clearly demonstrated. It has been stated that under the assumed condition the maximum velocity of discharge is equal to the circumferential speed of the wheel. This, however, is not true in all cases. In the "volume" type of fan, very large inlets in proportion to the size of the wheel, and a large number of shallow blades of considerably greater width than usual, are employed. A striking result of this arrangement is that the discharge velocity greatly exceeds, and may even approach a maximum of twice, the circumferential speed. Such fans are only suitable for moving large volumes of air against very small pressure, and are not adapted for foundry purposes. The "pressure" type of fan is designed with the object of enabling the velocity energy imparted to the air by the vanes to be converted into pressure energy at the delivery without loss due to eddies, etc., in the casing. This is accomplished (1) by enclosing the vanes between conical side plates, which extend from the inlet to the circumference of the wheel. The air is thus retained

within the revolving wheel until the required velocity has been imparted to it; and (2) by making the casing of involute form, in which the area of cross section gradually increases towards the delivery. A well known example, embodying both these features, made by the Sturtevant Engineering Co., Ltd., Queen Victoria Street, London, and largely applied for blowing cupola furnaces and smith's forges, is shown in Fig. 219. A double inlet (*i.e.*, on either side) having a diameter about half that of the wheel, is provided for both casing and wheel. In striking contrast to the "volume" type of fan, the width of the wheel at its outer circumference is about $\frac{1}{15}$, and at the inlet about $\frac{1}{6}$, of the diameter. Extending from the inlet to the circumference are six "major" vanes, between which are two "minor" vanes of about half the length. The vanes are all curved slightly backwards at the circumference. The casing is constructed in halves, the greatest diameter being about $1\frac{1}{2}$ times that of the wheel. The spindle runs in very long swivelling bearings, lined with white metal, and fitted with a special device for continuous oiling.

The *output of a fan or blower* is somewhat difficult to determine by calculation, and is best ascertained by direct experiment. The usual plan is to carry out the test with a "free discharge," as it is termed, in which a sheet iron guide tube, 8 or 10 feet long, is attached to the delivery orifice of the fan. An anemometer is suspended at the end of the tube, and from readings taken every two or three minutes during the test, the average velocity in feet per minute = v , of the current of air delivered may be obtained. Calling the area of the delivery pipe = a square foot, the output of the fan is then known to be = $v a$ cubic feet per minute. The theoretical volume of air discharged in one revolution of a blower = 4 times the shaded area in Fig. 220 \times inside length of casing. In practice there is, however, a certain amount of loss due to leakage and slip, and the difference in temperature of inlet and discharge should be allowed for. A constant or coefficient of discharge, determined by experiment for the particular type of blower referred to, is generally employed to make the necessary correction. Working at normal temperatures, and delivering against a pressure of about 21 inches of water, the coefficient = C , will be found to vary from $1\frac{1}{2}$ to $2\frac{1}{2}$, when, if A = shaded area as above in square feet, L = length of casing in feet, and R = revolutions per minute, the volume of

discharge = V in cubic feet per minute, may be found from the equation

$$V = 4 \text{ CALR.}$$

If the pressure to be produced does not exceed 12 inches of water, the pressure type of centrifugal fan is the most suitable and efficient to employ. For pressures of from 12 to 18 inches water gauge, the fan and the positive type blower may be regarded

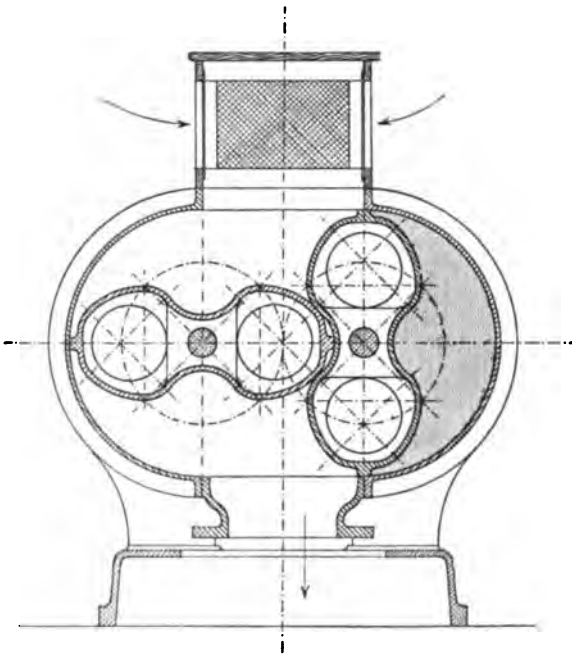

FIG. 220.—Roots' Blower.

as equally well adapted to the work, whilst above 18 inches the advantage is on the side of the blower, which in turn must give way to the blowing engine when a pressure of from 3 to 4 lbs. per square inch is reached.

It has been found that the average pressure due to the resistance offered by the material in the cupola varies from 21 to 28 inches of water, and the volume of air required is about 35,000 cubic feet per hour for each ton of iron melted. To deliver this quantity of air at a pressure of 21 inches water gauge

(= 12 ozs. per square inch) will absorb from $2\frac{1}{2}$ to 3 B.H.P., which may be taken as the average power per ton of metal melted. The mechanical efficiency of a fan working under such conditions is probably very low, the pressure required being considerably above the economical capacity of a single stage fan of the centrifugal type. For this reason, the fan, although possessing some advantage in regard to cost and suitability for electric driving by direct coupled motor, is not usually regarded as being so well adapted to foundry purposes as a blower of the positive type, such as the *Roots' blower* shown in section in Fig. 220. This is usually driven by belt from a counter-shaft, or by motor through

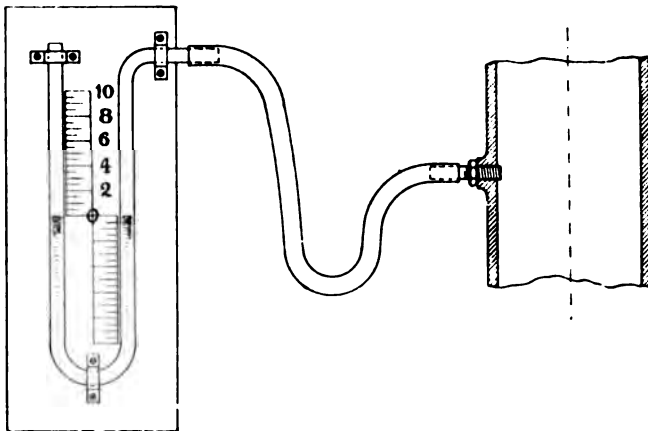

FIG. 221.—Pressure Gauge.

reducing gear. Two cast iron revolvers, machined to shape and at ends, rotate in an accurately bored-out casing, external gearing being employed to preserve the synchronism of the two shafts, and maintain the revolvers in proper relative positions for drawing in air at one side and expelling it from the other. A *pressure gauge* should be fixed in some convenient position near the blower, for recording the pressure of air in the blast main. The most usual form, Fig. 221, consists of a U tube of glass, partly filled with coloured liquid, one of the limbs being connected to the blast main by rubber tube. The other end is open to the atmosphere through a small hole in a brass cap, and the pressure may be read off by noting the level of the liquid in the

tube, behind which is a graduated scale showing the difference of level in inches.

The *Air Furnace* for foundry purposes, Fig. 222, is of the reverberatory type, somewhat resembling the puddling furnace

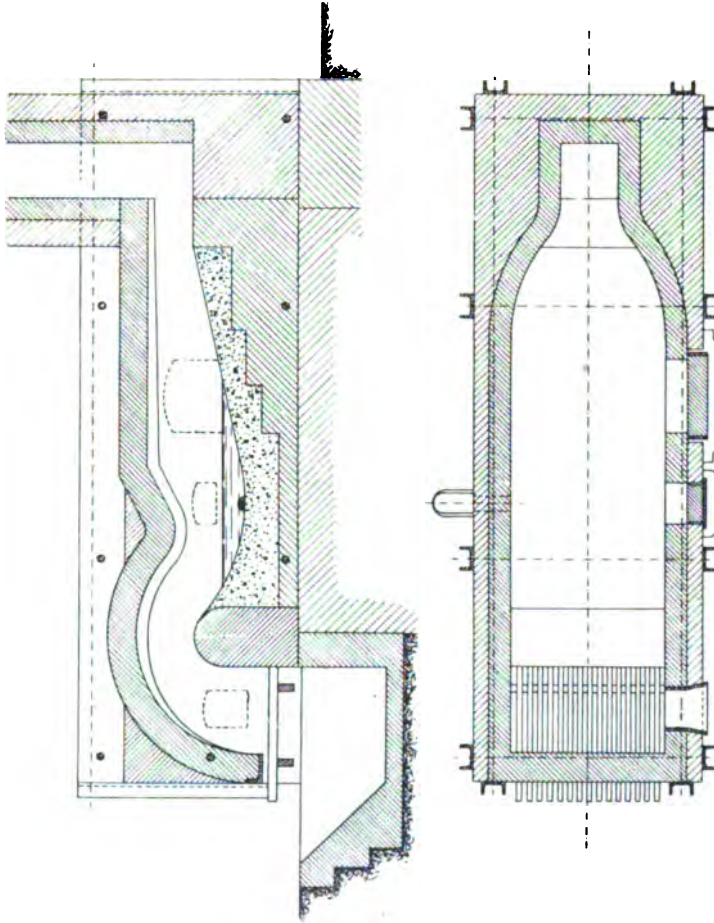

FIG. 222.—Air Furnace.

in arrangement. At one end is placed the firegrate, separated by the bridge from the hearth or melting chamber. The roof is of arched form, shaped so as to deflect the flame downwards upon the metal to be melted on the hearth. The bed of the furnace slopes upwards from the hearth to the bottom of the stack, and

on this slope the metal is first placed, to utilise the waste heat from the furnace. The tapping hole is on a level with the lowest part of the hearth, and immediately above it, just under the roof of the furnace, is a sight hole. The furnace is worked with natural chimney draught, and the flame may be varied at will from a neutral to an oxidising, or even smoky reducing, flame. In this respect the air furnace has a great advantage over the cupola. For melting bronze, an oxidising flame must be avoided, or great loss of zinc or tin will result. Charcoal is also to be preferred as the fuel, as the sulphur in coal may act deleteriously upon bronze. Air furnaces are generally used in foundries producing church bells, statuary, etc. To obtain the heat required for melting cast iron, it is necessary to burn coal with a surplus of air and a strong draught, giving an oxidising flame. This results in a loss of about 5 per cent. of iron melted, but silicon, manganese, and some carbon are also oxidised, giving a purer metal especially suitable for large and thick castings. Compared with the cupola, the air furnace is, however, slow, and its consumption of fuel is very high, amounting to from 10 to 15 cwts. of coal per ton of iron melted.

The *Crucible Furnace* is always used for melting small quantities of metal, not exceeding 2 cwts. For heavy castings, as in the case of crucible cast steel, the contents of a number of crucibles may be poured in succession into the mould, keeping up a constant flow until the mould is full, but the process is exceedingly troublesome and costly. The crucibles, either of fireclay or graphite, are provided with covers, the metal being in this way prevented from absorbing impurities from the fuel or products of combustion. The crucibles, having a very short life, are an item of considerable expense, and the consumption of fuel is very great, reaching from 1 to 2 tons of coke for each ton of metal melted. The crucible furnace is therefore only employed (a) where it is essential that the metal to be melted should not come in contact either with the fuel or with flame, as in the case of steel, the noble metals, etc.; (b) where loss of metal due to volatilisation or oxidation must be prevented; or (c) in dealing with a comparatively small quantity of an infusible metal.

The ordinary form of crucible furnace as used in the brass foundry will be seen in the photograph, Fig. 223, and is shown in section in Fig. 224. The illustration refers to the foundry at the

works of Messrs. G. and J. Weir, Ltd., Engineers, of Cathcart, Glasgow, which is reserved for repetition work in dry and green sand, and is provided with a battery of pot fires comprising seventeen furnaces, each suitable for crucibles holding



FIG. 223.—Brass Foundry at the Works of Messrs. G. and J. Weir, Ltd., Glasgow.

240 lbs. of metal. As seen in the lower right-hand corner, the battery is placed at the floor level, with ashpits in front, and gratings on which the melters can stand. It might be mentioned incidentally that extensive use is made of moulding machinery, which is situated mainly round the walls and in the centre bay. Closing and casting are carried on in the

centre floor. Lighting is effected from the roof, which is high and entirely glazed.

For brass or alloys, each crucible is placed in its own recess,

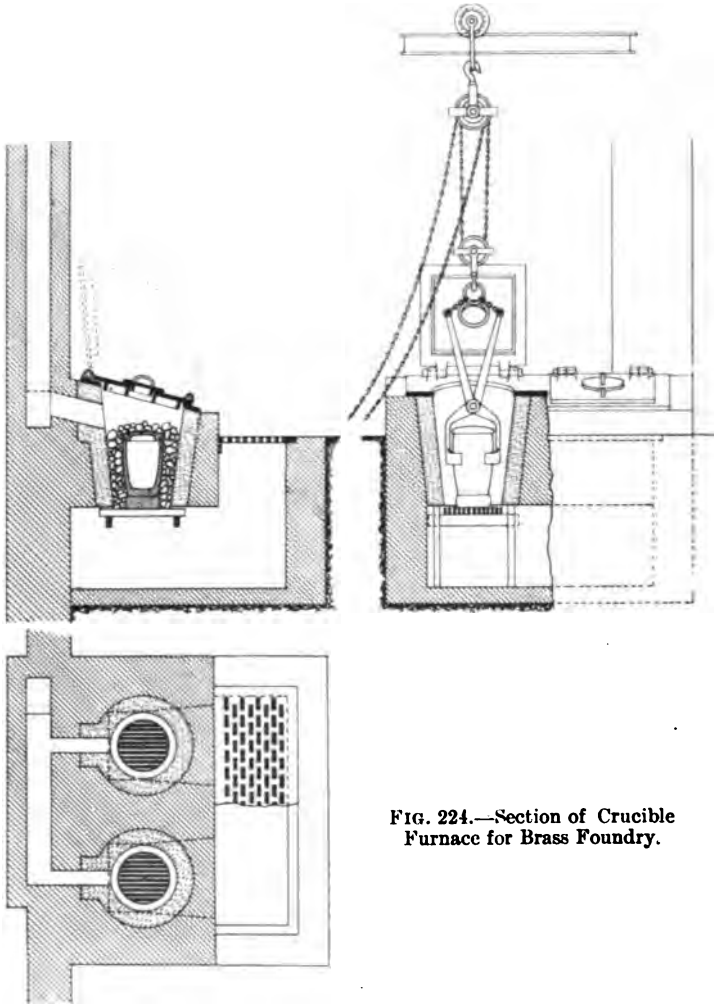

FIG. 224.—Section of Crucible Furnace for Brass Foundry.

hence termed a “one-pot hole,” at the bottom of which is the firegrate. The ashpit below the grate bars forms a portion of a vault constructed below the floor of the foundry, access being gained in this way to the row of pot holes or fires. The hole,

which is circular in plan, is lined with firebrick or ganister, and is just large enough to allow a thickness of 4 inches of coke all round the crucible. A separate flue is provided for each hole, leading into a common chimney stack which produces the necessary draught. A cover of firebrick encased in a wrought iron frame, is fitted to each hole, and is provided with a projecting bar or handle by means of which it may be drawn to one side for putting in or pulling out the crucible, or attending to the fire, which is kept filled up level with the top of the crucible. To prevent the chilling effect due to the firebars and the cold air first entering the grate, a "stool" of fireclay about 6 inches thick is placed under the crucible. The fuel employed for crucible furnaces is almost invariably coke, and although the gas-fired regenerative furnace would appear to have some advantages, it has never come into extensive use. With the ordinary method of working, the crucible is withdrawn by means of a pair of specially shaped tongs, Fig. 225, which must be applied with sufficient pressure to prevent the possibility of slipping. Hence there is some risk that the pot may be crushed in the tongs, and in any case, the sudden transition from the hot fire to the cold air is a source of danger and the main cause of the short life of the crucible, which on the average only reaches about 15 heats. These difficulties in handling the pot led to the introduction by Piat of the

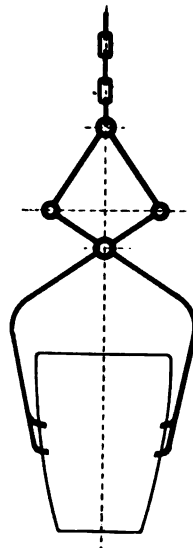

FIG. 225.—Crucible Tongs.

Tilting Furnace, Fig. 226. The body of the furnace consists of a steel plate shell lined with firebrick, and having a grate at the bottom on which the crucible stands in the usual way. Below the grate is an air chamber, to which air is supplied under pressure. The furnace is mounted on trunnions, and may be rotated into the position shown in dotted lines by worm and worm-wheel mechanism operated by hand-wheel. A spout is formed through the firebrick lining on a level with the top of the crucible, the contents of which can thus be poured into a ladle by simply tilting the furnace. In another arrangement, the

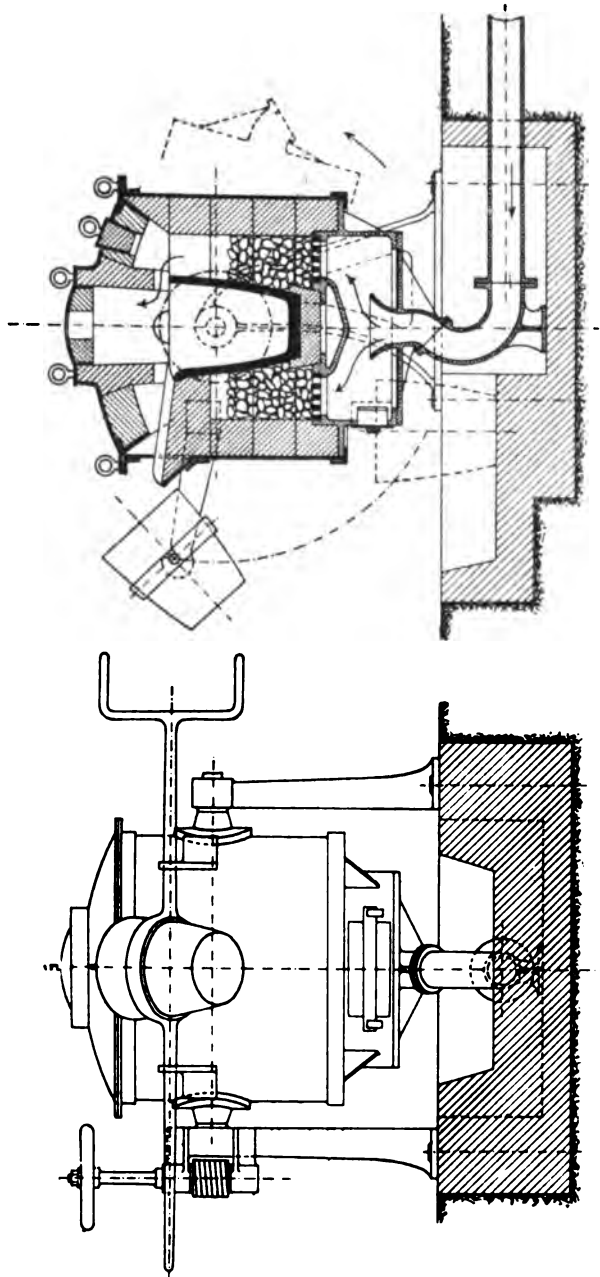

FIG. 226.—Tilting Furnace.

furnace, instead of being rotated, is lifted bodily by a crane, on which it is carried to the mould, and its contents poured in exactly the same way as when using a ladle. With the blast under pressure, combustion is much more complete, and as there is no cooling when once the furnace has been heated up, a great saving in fuel results. The crucibles also last much longer, although the melting is more rapidly performed, taking only from 20 to 30 minutes.

Gas-Fired Crucible Furnace.—Experiments at the Royal Mint have shown that gas-fired furnaces are particularly convenient and economical for melting bullion and certain precious metals. For such a purpose, any kind of fuel-gas, whether coal-gas, producer-gas, or oil, may be used, the burner being, of course, modified to suit. At the Mint, the system adopted is that introduced by Mr. S. N. Brayshaw, the well-known expert of

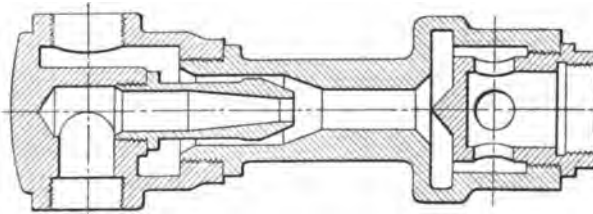

FIG. 227.—Burner for Crucible Furnace.

Manchester, town's gas being taken at the ordinary pressure from the main (about 3 inches of water) and mixed with air at a pressure of about 2 lbs. per square inch. Efficient combustion depends mainly upon the correct form of the burner nozzle, and of its firebrick extension in the furnace. The burner designed and patented by Mr. Brayshaw is shown in section in Fig. 227. The gas and air supplies are capable of independent regulation, and the cocks are provided with graduated quadrants to allow of easy and exact adjustment of the respective volumes. The gas and air combine in the nozzle, which somewhat resembles that of an injector, but the resulting degree of admixture is by no means sufficiently perfect to enable the highest possible temperature to be attained. The stream of air and gas is therefore delivered to the mixing head, the arrangement of the pockets and passages in which is designed, as the result of the baffling and eddying action which takes place, to effect the most

intimate mixture possible. In this way temperatures up to 2400° F. have been obtained in the Brayshaw crucible furnaces at the Royal Mint with gas of 150 B.T.U.'s, and the cost of fuel has been reduced to 4½*d.* per cwt. of standard gold bullion as compared with 7*d.* when coke was used. The furnace itself is shown in Fig. 228. The cylindrical sheet steel casing is made double with the intervening space filled in with non-con-

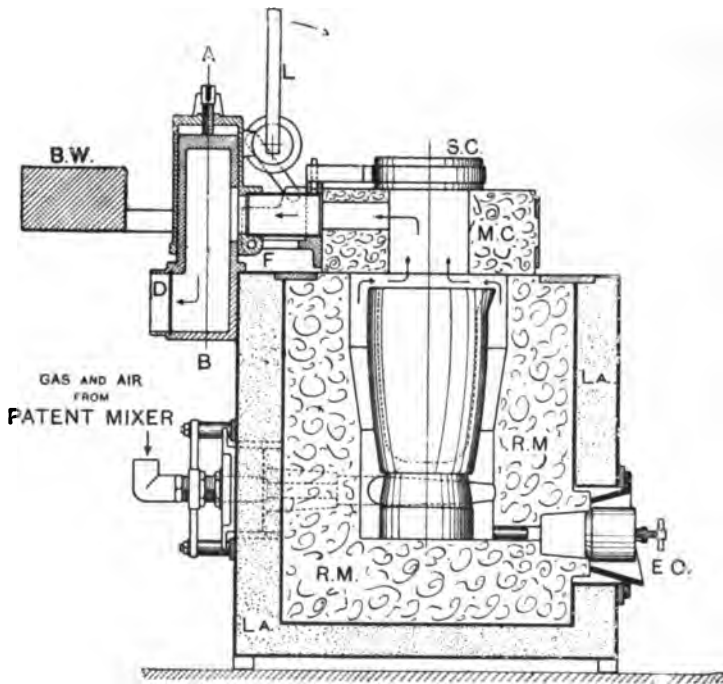

FIG. 228.—Brayshaw's Crucible Furnace.

ducting lagging, LA. The lining of the furnace consists of a specially moulded solid block of refractory material, RM, which may be easily and rapidly replaced when required. It will be noticed that the combustion chamber, which is reduced to the smallest practicable dimensions in order to concentrate the heat on the crucible of metal, is provided with an emergency outlet, EO. The mixture of gas and air from the burner above described, is admitted tangentially just below the bottom of the crucible.

The products of combustion pass away through an opening in the main cover, MC, to a damper, D, connected with the chimney. The cover, MC, is counterbalanced by a weight, BW, and when raised through a short distance vertically by the lever, L, is capable of turning horizontally about the line AB as a pivot. To remove the crucible, the cover, MC, is first swung laterally out of the way, when the lift is effected by means of tongs as usual. For charging the crucible, or examination of its contents, a small cover, SC, fitting over a hole in the main cover, is provided. At the Mint, there are four Brayshaw furnaces for melting gold, each pot holding 2,600 troy ounces, and sixteen furnaces, each taking a 400 lb. crucible, for melting silver and bronze.

CHAPTER XXV.

THE PRODUCTION OF STEEL CASTINGS.

FOR the production of large and heavy castings, the Siemens open-hearth process already described is without a rival, and is also much the cheapest, at any rate on a large scale. But the

plant is costly, and must be kept going continuously day and night. On the other hand, the use of the crucible furnace, although well adapted for steel of the highest quality, is very costly, and of necessity restricted to comparatively light work. Steel cannot be melted in a cupola, as carbon, sulphur, and other impurities would be absorbed from the fuel. A great demand has sprung up for steel castings of small size, and there are many instances in which it has been found desirable to add a small steel-making plant to the equipment of the iron foundry.

With this object in view, much attention has been given to the application of the Bessemer process on a small scale, and several modifications are now working quite successfully. The principle of working, and the reactions which take place, are substantially those occurring in the ordinary Bessemer converter, the

only difference being in the manner of introducing the blast. This can be done in four ways: (1) from below vertically through the bath of molten metal, as in the original Bessemer process already described under the heading of steel manufacture ;

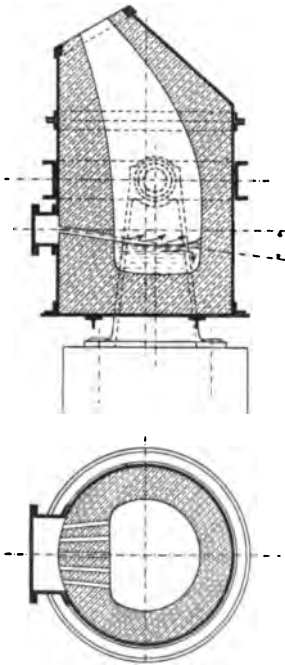

FIG. 229.—Side-blown Converter.

(2) from the side through the molten metal, as in Roberts' process; (3) from the side but above and parallel to the surface of the molten metal, as in the Tropenas process; and (4) from the side but at a certain angle with the surface, as in the "Stock" process, Fig. 229. Each of these methods has been shown to



FIG. 230.—The "Stock" Converter.

be capable of producing steel of thoroughly reliable quality. Surface blowing has the great advantage that the pressure of the blast, not having to overcome the head of liquid metal, may be much reduced, and by blowing in an inclined direction upon the surface, the oxidising action is more complete. The "*Stock*" Converter, made by Messrs. Thwaites Bros., Ltd., of Bradford, is especially suitable for the purpose named, enabling even $\frac{1}{2}$ -ton

charges to be made into steel of excellent quality. The general construction of the converter is shown in Fig. 230. It consists of an ordinary side-blown converter, preferably of oval section, mounted on trunnions which are supported on a steel frame, the latter in turn resting on a roller-path in the base plate. In order that the converter may be turned round in a horizontal plane, the blast enters by a main passing through the centre of the base plate, proceeding by the vertical pipe on the outside to one of the trunnions, which is hollow, and thence to the blast box on the side of the converter. The usual worm and worm-wheel gear, operated if need be by an electric motor, is provided for rotating the converter vertically into the blowing position. The charge of pig iron is melted in the converter itself, using oil as the fuel. A small air compressor working up to a pressure of 35 lbs. per square inch is employed for forcing the oil, which may be the crudest petroleum, through the oil-burners contained in the blast box. In addition, blast for conversion is supplied by a blower at a pressure of from $2\frac{1}{2}$ to 3 lbs. per square inch, its temperature being raised to about 800° F. in the economiser or "recuperator," Fig. 231. This consists of a series of ribbed cast iron pipes of U form through which the blast passes on its way to the converter. The waste heat arising from the combustion of the oil during the melting of the iron circulates round the outside of the pipes, which are placed in a flue leading to the chimney. The oil is first turned on, and the vessel raised to a white heat. It is then brought into the charging position, Fig. 232, and the necessary quantity of hematite pig iron is introduced. For melting the charge, the converter is turned into the horizontal position, Fig. 233, with its nose pointing to the entrance of the economiser. The blower is then started, followed by the air pump, which forces the oil through the burners in the blast box, the oil being ignited by the heat of the converter. The combination of oil and blast produces an intense heat, which melts the charge in about $1\frac{1}{2}$ hours. As soon as the metal is melted, the oil supply is cut off, and the burners removed from the blast box, this operation occupying two or three minutes. The converter is now turned into the upright position for blowing, Fig. 234, which lasts about 20 minutes, and conversion is accomplished in the ordinary way. After turning down to the inclined position, the blast is shut off,

and a weighed amount of ferro-manganese or ferro-silicon is added to "re carburise" the steel to the desired extent. Finally, the converter is brought into the position, Fig. 235, for teeming

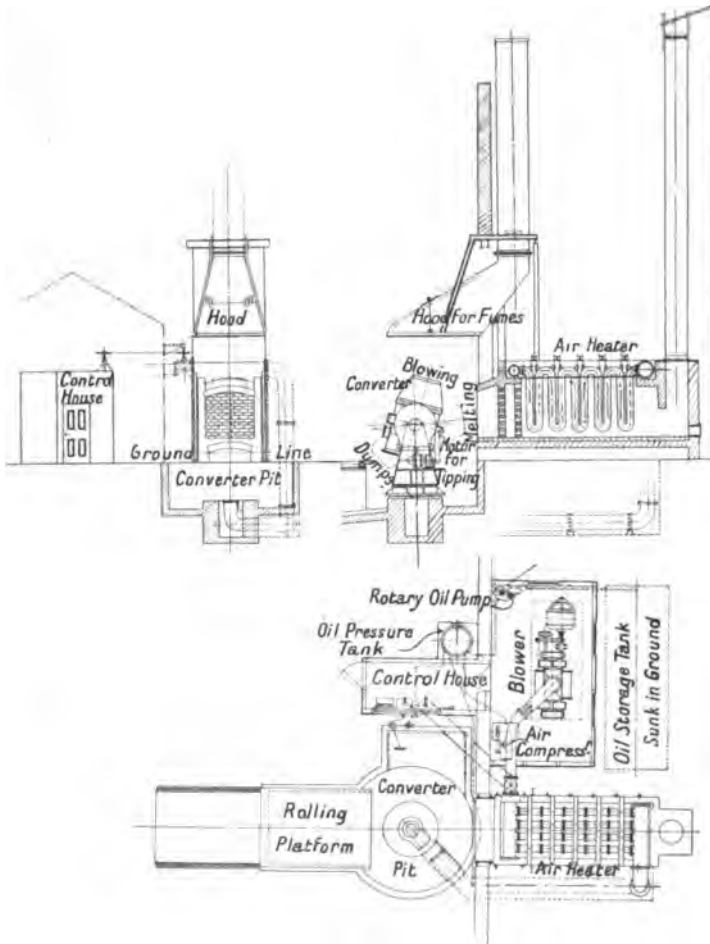

FIG. 231.—The "Stock" Converter Plant.

into the ladle. The metal is exceedingly fluid, and it is possible to make difficult and intricate castings perfectly sound and free from blowholes.

Malleable Cast Iron.—It has been pointed out that castings of wrought iron cannot be produced. Castings of exceedingly mild



FIG. 232.—Stock Converter. Charging Position.



FIG. 233.—Stock Converter. Melting Position.

and almost carbonless steel, to which a small percentage of aluminium has been added, were introduced by Nordenfelt under the name of "Mitis" castings. In the malleable cast iron process the object is to produce a material similar in chemical composition to wrought iron, by depriving ordinary iron castings of their carbon. The castings are first made in the



FIG. 234.—Stock Converter. Blowing Position.

usual manner from a hard, brittle, white iron, melted in a cupola as usual. After dressing or pickling for the complete removal of the sand which may adhere to them, they are packed in cast iron boxes with powdered red hematite ore, and the covers luted on with fireclay. The pots are then placed in the annealing oven, and the heat raised gradually to about 1550° F., according to the size of the castings; the operation lasts from

three days to a week, after which they are allowed to cool down slowly. The oxygen of the ore (which is red oxide of iron, Fe_2O_3) combines with the carbon in the castings, reducing the



FIG. 235.—Stock Converter. Teeming Position.

amount of the latter element to less than 1.0 per cent. The method is thus the reverse of the cementation process of steel making. The tensile strength of malleable cast iron may be equal to that of ordinary wrought iron, but its ductility, measured by elongation, is only about one-third.

CHAPTER XXVI.

POURING THE MOLTEN METAL—LADLES—CLEANING AND FETTLING CASTINGS.

Pouring the Molten Metal.—The metal, having been melted by any of the methods just described, is tapped into *ladles*, in which it may be carried to any part of the moulding floor and poured into the moulds as required. In brass and aluminium founding, pouring is done directly from the crucible, which is transported from the furnace to the mould in the same manner as a ladle. For small casts, the hand-shank ladle, having a capacity of about $\frac{1}{2}$ cwt., is employed, Fig. 236 (*a*). For larger sizes, say from 1 to 3 cwts., the shank is double-ended, to be carried by two men, as in Fig. 236 (*b*), the straight end acting as a trunnion, round which the ladle is rotated by the forked or pouring end. Fig. 236 (*c*) shows a still heavier, or crane ladle, to contain 5 to 20 cwts. The trunnions, formed on a ring or belt riveted to the body of the ladle, rotate in an arched frame or "bail" which can be slung from the crane hook, a catch being provided to prevent accidental tipping. To avoid the risk of accident should the man lose control, and to ensure steady pouring, it is safe to say that the geared crane ladle, Fig. 236 (*d*), should always be adopted for capacities of 10 cwts. to 10 tons or more. The tipping gear consists of worm and worm-wheel in combination with a pair of mitre wheels, the latter being employed to bring the operating wheel parallel to the plane of rotation of the ladle. The pouring is thus under better control, and the workman need not approach so near to the ladle. The wheel or handle shaft is generally loose, so that it may be readily changed from one mitre gear shaft to the other, to enable the man to stand either at the side or at the front, as may be most convenient. In addition to the trunnion ring, large ladles are stiffened by a ring riveted round the upper edge, and pouring lips are usually provided on one or both sides. A layer of more or less fluid slag and ashes or "scoriæ," always floats upon the

surface of the metal in the ladle, and as this must not be permitted to enter the mould, an iron rod of suitable shape is

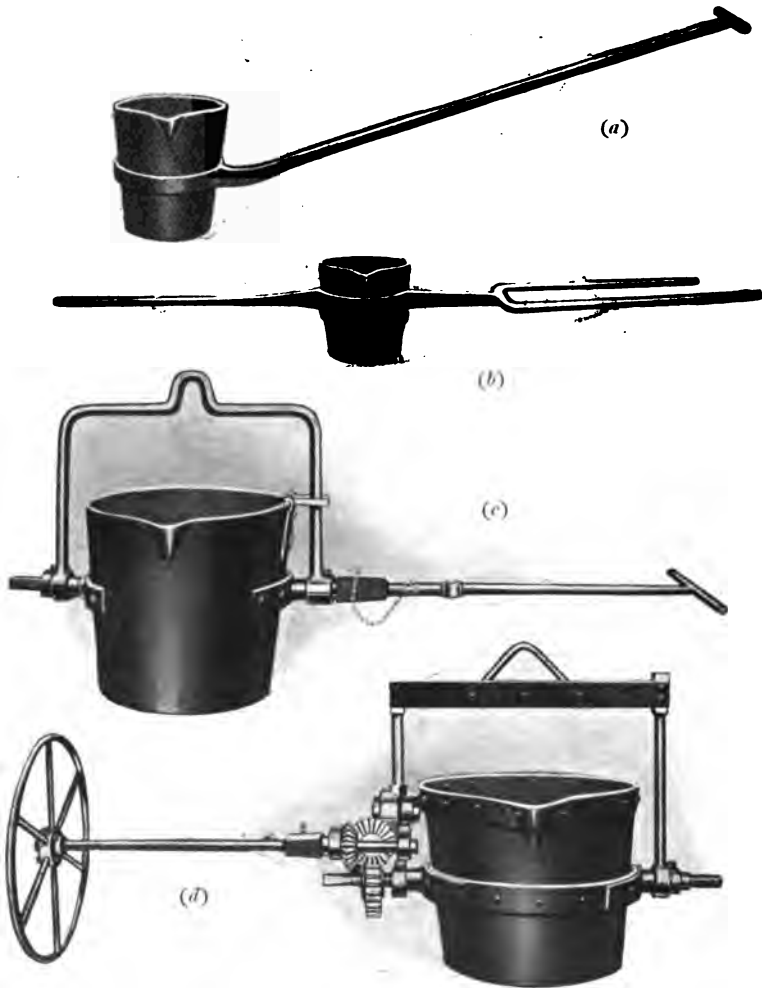

FIG. 236.—Various Forms of Foundry Ladle.

held across the mouth during pouring. Obviously a better method is to take the metal from the bottom of the ladle, as is done in steel ingot casting. In the *self-skimming ladle* of Messrs. Goodwin and How this is accomplished in a very simple manner

by the use of a removable "skimmer" or dividing plate, coated with fireclay, and reaching nearly to the bottom of the ladle, as shown in Fig. 287. Ladles are now made of stamped or pressed steel, but the larger sizes are of riveted steel plate. Every morning before casting they are "daubed up" with loam,

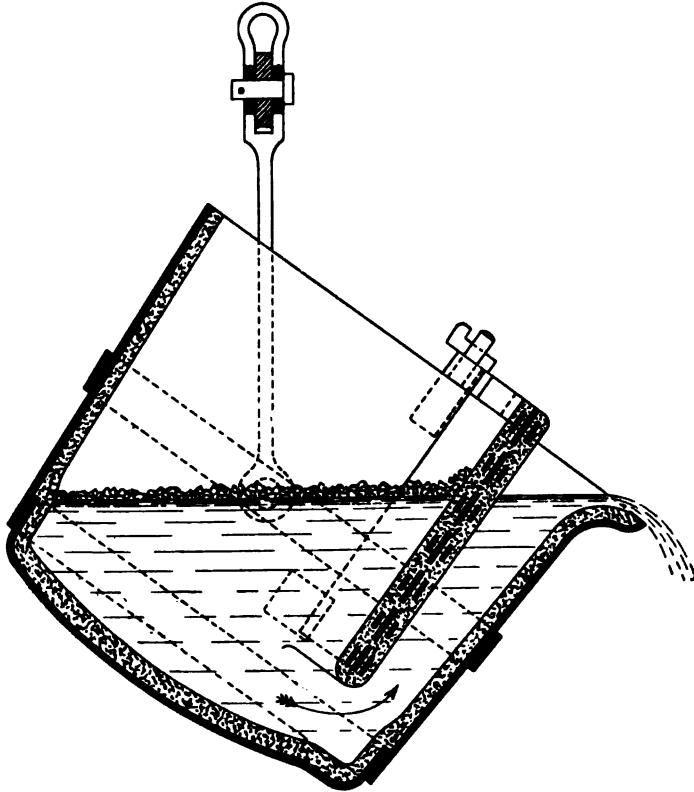

FIG. 237.—Self-skimming Ladle.

thoroughly dried and blackwashed. Very large ladles are usually lined with fireclay. For steel casting, non-tipping or bottom-pouring ladles must be used, as open-hearth steel is not sufficiently fluid to admit of pouring from the spout of a ladle. *Steel-casting ladles* are either of the crane or carriage type, an example of the latter being given in Fig. 238. The carriage or bogie may be drawn by a locomotive, or may be moved by hand

by means of spur gear and chain drive. The ladle is lined with fireclay, and to the bottom is fitted a "nozzle-box," carrying a valve seat or "nozzle" of fireclay. Into this fits a fireclay valve in the form of the rounded end of the "stopper head." This is fixed to the stopper rod, which is surrounded by a tube of fireclay to protect it from the molten steel. The stopper rod is connected

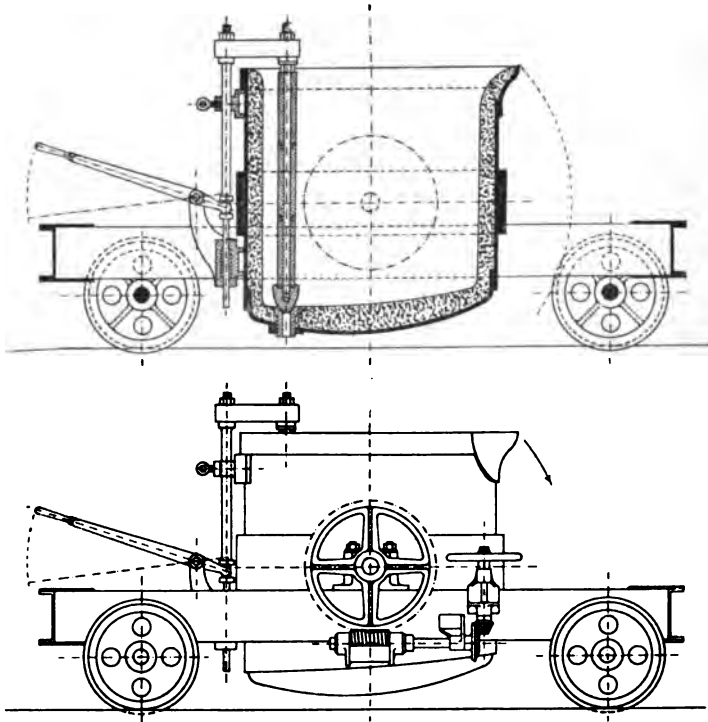

FIG. 238.—Steel-casting Ladle.

by a cross-head at the top to a vertical bar moving in guides outside the ladle, and operated by a hand lever, so that when the stopper is lifted the steel flows out through the pouring nozzle. The ladle turns on trunnions, and by means of worm gear may be inverted after casting for the purpose of emptying out slag, etc.

Cleaning or Fettleing Castings.—After removal from the sand, and when sufficiently cool to handle, the castings are taken to

the fettling shop and the cores are knocked out with an iron bar. With cast iron, it is an advantage if gates and risers can be broken off with the hammer while still red hot, but on account of the ductility of the metal, they must be removed from steel castings by sawing off. Small castings of iron or steel are most effectively cleaned in the *rattler* or *tumbling barrel*, Fig. 239. This consists of a revolving box of square, octagonal, or cylindrical form, in which the castings are loosely packed, a removable door being provided on one side to give access to the interior. The rubbing action which results effects the removal of a good deal of the sand and dirt adhering to the surface of the



FIG. 239.—Foundry Rattler, or Tumbling Barrel.

castings. As the dust produced is very objectionable, and injurious to the health of the workmen, the machines are sometimes connected to a duct through which the air is exhausted by a fan. The difficulty has, however, been got over in a still more effective manner by causing the tumbler to revolve in a tank of water, Fig. 240, which circulates freely through the perforations in the staves, washing out the sand and dirt. This type of machine is supplied by Messrs. J. W. Jackman & Co., Ltd., of Manchester. For brass castings, the rattler is constructed of hard wood, coarse sand and a small quantity of water being introduced with the castings. After the tumbling process, the castings are taken to the grinding machines, and gates,

projecting lumps or rough places are removed on an emery wheel. Large and heavy castings must be cleaned by hand, hammering, scraping, and brushing with steel wire brushes being resorted to for the removal of the sand. Fins and risers are cut off with hammer and chisel, the latter sometimes operated by compressed air. In recent years, great use has been made

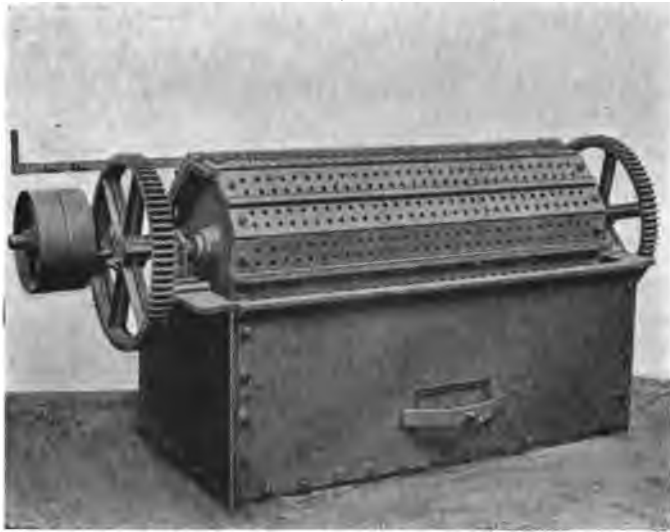

FIG. 240.—Water Rattler.

of the sand blast process for cleaning castings, but the equipment is rather costly, and can only be adopted on a large scale.

The sand adhering to iron castings is sometimes removed, and the hard skin dissolved away, by chemical means to facilitate machining. This process, known as *pickling*, consists in immersing the castings for a short period in a bath of dilute sulphuric acid, followed by washing in a stream of water.

CHAPTER XXVII.

DEFECTS IN CASTINGS AND THEIR REMEDY.

Defects in Castings.—The causes contributing to the production of bad castings or “wasters” are of three kinds, and may be traced to defects in the design, in the mould, or in the metal. Instances of faulty design have already been considered in connection with the effects of contraction, etc., in cooling, and it now remains to note some of the common defects for which the moulder must be held responsible. The most frequent cause of trouble in this respect is undoubtedly the presence of “air” or

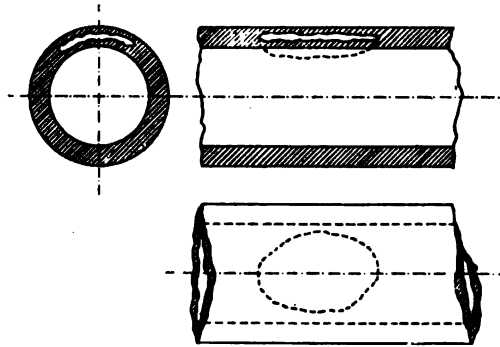

FIG. 241.—Blowholes in Casting.

gas in the mould and cores, the defects arising from which may be classified as (1) blowholes ; (2) scabs ; and (3) honeycombing and sponginess. *Blowholes*, Fig. 241, occur in the interior of a casting, generally in the upper part, and as a rule cannot be detected from the outside, or are not discovered until the outer skin has been machined off. Blowholes may be caused by the sand being too wet, by low temperature of the metal, or by excess of sulphur, but it may be that the mould has been rammed harder than necessary, or has been imperfectly vented, no means of escape being afforded to the confined gases. A *scab*, Fig. 242, is

an irregular thickening or excrescence caused by the falling in, or the erosion, of a portion of the mould. When the metal is poured into the mould, gas may be disengaged with such violence

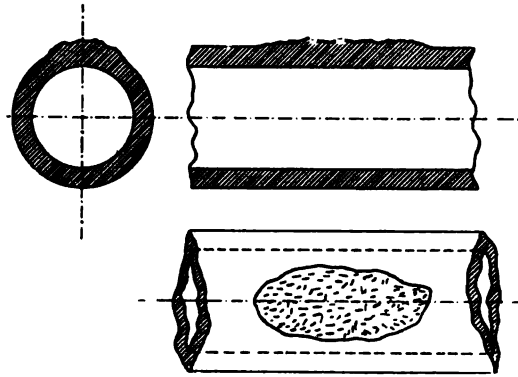

FIG. 242.—Scab in Casting.

as to break up the sand, which is then washed away, and the resulting cavity filled with metal. Scabbing may also be caused by the inflowing metal washing away part of the mould as the result of placing gates and risers in the wrong position. Regarded

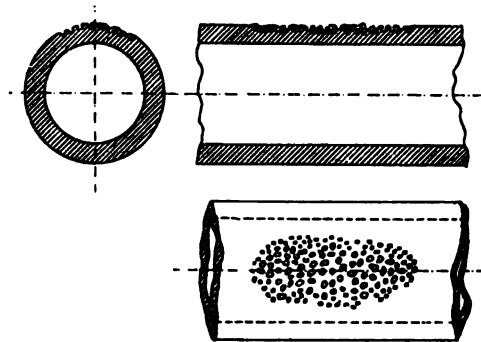

FIG. 243.—Honeycombing in Casting.

as a lump which might easily be cut off, the scab itself might not be a very serious defect, but it must not be forgotten that the sand which has been displaced is contained somewhere in the casting, which is almost invariably a waster in consequence. *Honey-*

combing or sponginess is an external defect consisting of a number of small cavities in close proximity, Fig. 249, which usually come through and are apparent on the surface. It is caused by dirt or "scurf" held mechanically in suspension in the molten metal and is due to imperfect skimming in the ladle, or it may be, to poor metal. The impurities being lighter than the metal, rise to the upper part of the casting, often accompanied by bubbles of gas if the venting has not been properly attended to. A skimming gate for intercepting dirt is a useful precaution. Porosity which is rendered apparent by the slight leakage or "sweating" which sometimes occurs under hydraulic pressure, is due to other causes, and is perhaps best avoided by adding low silicon pig to the mixture in the cupola. This acts as a "hardener," closing the grain of the metal. In addition to the faults described, there are other defects, which may be attributed directly to the temperature of melting, to the method of pouring the metal into the mould, or even to the nature of the metal itself. The advice generally given is to melt the iron very hot, but to pour it at a temperature having some relation to the nature of the work. For the production of thin castings, hot iron is a necessity, while for large and heavy work, it should be allowed to cool down in the ladle to the required temperature. It is also desirable to get the metal into the mould as rapidly as possible, consistent with the strength of the mould itself. If the metal is poured too slowly, there is considerable danger of a *cold shut*—a defect arising from partial solidification of the stream before the mould is properly filled. If a casting has to be machined on both top and bottom faces, and has to be perfectly clean, it is necessary to pour with hot metal, whether the casting be large or small.

Steel Castings.—The remarks made as to the causes tending to produce unsoundness in iron castings apply with still greater force to steel. The chief source of trouble in the manufacture of steel castings is the very high temperature required to produce fluidity, probably not less than 2700° F. It is by no means easy to obtain a material suitable for facing the moulds, which, although thoroughly refractory at this high temperature, is at the same time sufficiently porous to permit the escape of any gas. It has been shown that molten steel possesses the property of *occluding*, or dissolving, many times its own bulk of gas, which is evolved during cooling. The risk of blowholes is therefore

much greater with steel than with iron, unless special precautions are taken to facilitate the escape of gas from the mould. On account of the high melting point, the coefficient of contraction for steel, viz., 0·2 to 0·25 inch per linear foot is nearly double that of cast iron. It is therefore necessary to adopt special methods for relieving contraction stresses as rapidly as possible

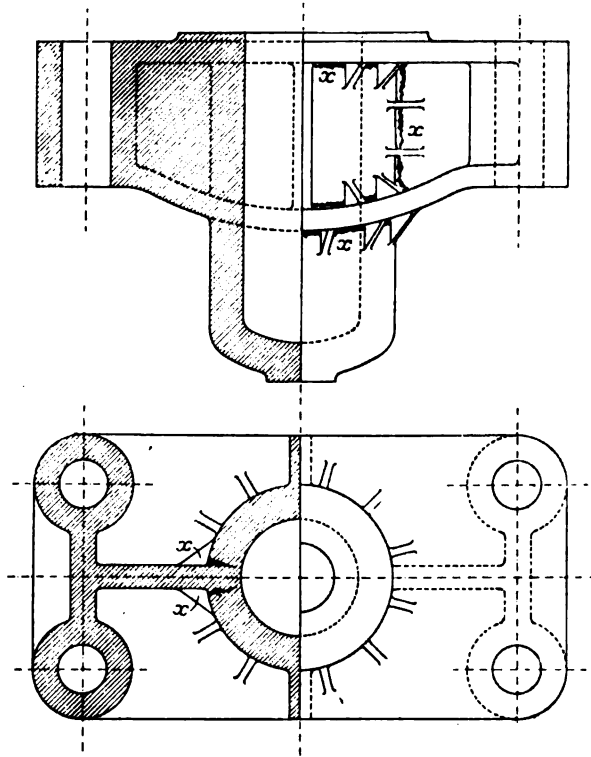

FIG. 244.—Use of Angle Ribs in Steel Casting.

during cooling, and for this reason moulds and cores for steel must be much more compressible than those for iron, to permit the excessive shrinkage without “pulling” the casting. Difficulties due to unequal contraction are perhaps the most serious with which the steel founder has to contend, and it is not too much to say that in the majority of cases they can be altogether obviated or overcome by correct design. It is of the

utmost importance that steel castings should be kept uniform in thickness, sharp corners being prohibited, and instead, all junctions well rounded out. Only the simplest shapes should be adopted, and thick faces, bosses, lugs, etc., should not be added to an otherwise simple form. In attempting to take advantage of the superior strength of steel, excessive lightness must be avoided. A feature peculiar to steel castings is the *use of small brackets or angle ribs* at the junction of two parts at right angles, Fig. 244. Here the corner is longest in cooling, and the sides in contracting

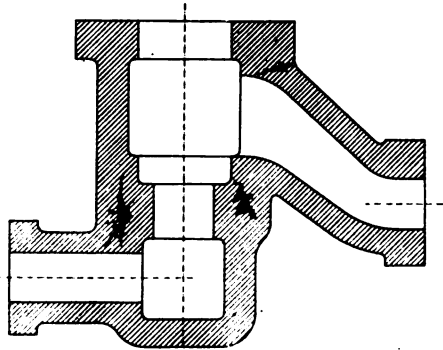

FIG. 245.—Shrink-holes in Steel Casting.

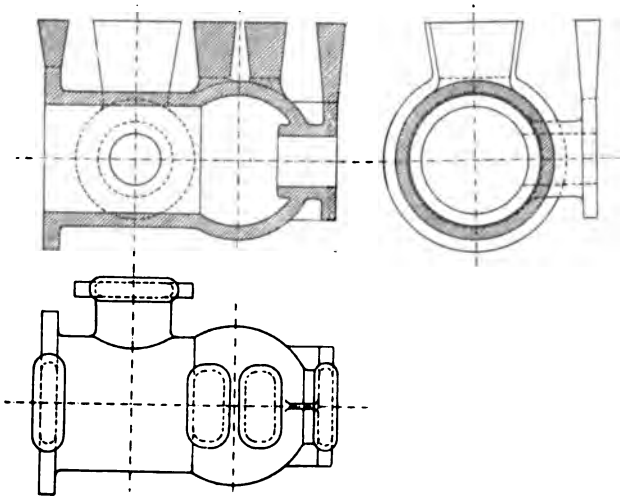

FIG. 246.—Steel Casting for Pump Cylinder.

from it tend to induce a starting point for fracture at *x*. To prevent this, the moulder cuts out thin webs at about 6 inches

centres along the corner fillet. These webs cool first, and then serve to retain the sides in position during the process of solidification. The webs may be cut away after the casting has been annealed. Great care must be taken to avoid thick places in the interior of a casting, as for instance, in the hydraulic valve box, Fig. 245. "Shrink-holes" are certain to be formed, as shown,

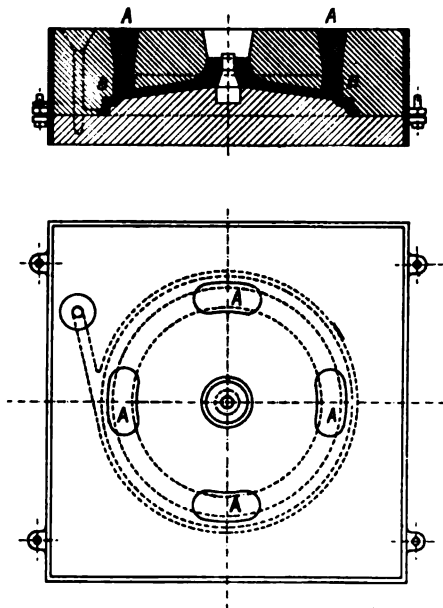

FIG. 247.—Steel Casting for Piston of Marine Engine.

where a thick mass of metal occurs and as this will also form a path of least resistance along which occluded gases endeavour to escape, blowholes are almost always found in the neighbourhood, often breaking through into the interior. A "sink head" or riser must therefore be placed in communication with any part of a steel casting where shrinkage is liable to occur. In this way, the interior can draw upon a fresh supply of metal as contraction proceeds, and at the same time the riser acts as a path of escape for any gases. Molten steel is not nearly so fluid as cast iron, and unlike cast iron, does not expand slightly on cooling. To obtain a sharp impression, it is desirable to have a good head of metal in the risers, which should be made much larger than for cast iron. These points are well brought out in the two examples given. Fig. 246 shows a *pump cylinder*, with risers placed directly over each junction where shrinkage is likely to occur. A still more striking case is found in the *piston* for a marine engine, Fig. 247. A head, B, in the form of a ring is cast round the outer circumference, communicating with a

number of risers, A, at intermediate points. The ring, B, is of course afterwards removed in the lathe. Steel castings generally lack the smoothness of surface which is easily obtainable with cast iron. The intense heat of molten steel renders it liable to burn into the sand, even when pure quartz or silica sand is used for facing. Moulds for steel must be thoroughly baked, to drive off every trace of moisture, as the presence of steam will produce a rough or scabby surface, if nothing worse. It is of the utmost importance that all steel castings should be thoroughly annealed, to relieve internal stresses set up as the result of the large amount of contraction during solidification. The annealing furnace is usually of the reverberatory type, fired with producer gas. A non-oxidising or smoky flame is required to prevent the scaling which would otherwise occur. The castings are slowly heated up to, and maintained for about three days at, a temperature of 1700° F. The furnace is then luted up, and the castings allowed to cool as slowly as possible, the time extending over four or five days. The increase in ductility and toughness produced by annealing is very remarkable.

CHAPTER XXVIII.

FOUNDRY MIXTURES.

A SINGLE brand, or one particular number of any brand of iron is very rarely used alone for foundry purposes. It is always found that the best results as regards both strength and toughness are obtained by mixing a number of carefully selected brands, and the mixture varies with the thickness, size, and intended purpose of the casting. For light ornamental work, strength is of no consideration, but it is essential that the metal should be extremely fluid, and capable of taking a sharp impression. Cast iron containing phosphorus, although weak and brittle, is very fluid when molten, and is therefore eminently suitable for the purpose named. On the other hand, for engine and machinery castings, strength is usually the chief desideratum, and stronger and purer iron must be employed. As a rule, it is not advisable to use a mixture of all pig, as a certain proportion of good scrap makes the castings both stronger and cleaner. If, however, very soft castings are required for machining, a mixture of (say), two brands of pig and no scrap may be used, as it is found that re-melting hardens the iron. On the other hand, engine cylinders, being subject to much wear, are specified to be cast of tough close-grained metal, as hard as can be worked. This is met by mixing pig iron with one or more cold-blast brands, the latter having a peculiar hardening effect, or it may be that a small proportion of mottled or even white iron is added with the same object. Steel scrap in small quantity is sometimes added to produce great toughness, as in the case of hydraulic cylinders, etc. ; but the expedient is liable to give trouble, and the metal must be kept at a high temperature in the cupola much longer than usual to effect thorough mixing.

The result of melting iron in the cupola is to bring about some alteration in the proportion of certain of the elements present. On the average, there is a loss of 10 per cent. of the silicon, and

15 per cent. of the manganese, while sulphur may be increased as much as 50 per cent. by absorption from the coke fuel used in melting. Carbon and phosphorus remain practically unaltered, but there is a loss of iron, which, becoming oxidised, passes off in the slag, such loss amounting to from $\frac{1}{2}$ to $\frac{3}{4}$ per cent. of the metallic iron contained in the mixture. Allowance must be made for these changes in calculating the composition of the charge. The influence of the various elements on the strength and properties of cast iron has already been noticed under the head of pig iron. The injurious effect of sulphur must be carefully guarded against, and as this element cannot be eliminated, it is necessary to commence with iron and coke as free from it as possible. The next point of importance is to decide upon the proper content of combined carbon, which is largely controlled by the amount of silicon and manganese present. Castings containing a large amount of graphitic carbon are termed "soft," and are easily machined. In this case the combined carbon should not exceed 0.2 per cent. With increase in combined carbon, the metal becomes harder, and up to a certain point stronger. The maximum tensile strength is said to be reached with 0.5 per cent., the greatest transverse strength with 0.7 per cent., and the maximum strength in compression with not less than 1 per cent. of combined carbon. In an ordinary pig iron containing 3.5 per cent. of total carbon, with the other elements in normal proportions, the combined carbon will amount to 0.5 per cent., the remainder, 3 per cent., being of course, graphitic. By varying the content of silicon and manganese, the combined and the graphitic carbon may be made interchangeable within certain limits. Less than 4 per cent. of silicon exercises a softening effect by causing the carbon to take the graphitic form. Absence of silicon will cause the greater part of the carbon to take the combined form, or become "white," but with about $3\frac{1}{2}$ per cent. silicon present, almost the whole of the carbon becomes graphitic. Manganese, on the other hand, changes graphitic carbon into combined, thus increasing the strength and hardness. Sulphur also changes graphitic to combined carbon, hardening the iron; but to a certain extent manganese neutralises the effect of the sulphur, combining with it to form manganese sulphide which passes off in the slag. Manganese thus tends to soften high sulphur iron, and improves the metal by preventing blowholes.

The steps to be taken to produce any desired result may be summed up as follows:—

To Increase Strength.	To Reduce Shrinkage.	To Prevent Blowholes.
Increase combined carbon. Increase manganese. Reduce graphite. Reduce silicon. Reduce phosphorus.	Increase graphite. Increase silicon. Increase phosphorus. Reduce sulphur.	Increase manganese. Reduce sulphur.

The suitability of an iron for any particular purpose cannot be judged by the appearance of the fracture alone, and due regard must always be given to chemical composition, or "analysis." The percentages of carbon, silicon, manganese, phosphorus, and sulphur, to give a desired result, are now known within certain well-defined limits, and in making up a mixture, the proportion of each of its contents should be calculated with this object in view. Much, however, must be left to judgment and experience, as several factors do not admit of easy determination.

It has been pointed out that the use of scrap is beneficial, and in fact its employment is obviously a necessity. Even granting that the analysis of a certain make of pig may be relied on, it is quite impossible to ascertain by chemical analysis or otherwise the exact composition of scrap, which may vary greatly with almost every piece. On the authority of Mr. E. L. Rhead, of Manchester University, good machinery scrap may be taken to contain on an average—

Total carbon	2·0 to 3·0	per cent.
Silicon	1·5	„ 2·0 „
Manganese	0·2	„ 0·75 „
Phosphorus	0·2	„ 0·8 „
Sulphur	0·05	„ 0·1 „

Calculation of Mixtures.—Some such approximation, together with the analysis of the pig, should prove a valuable aid to the founder in arriving at the required composition of the mixture. For example, suppose castings are required to contain 2 per cent. silicon, 0·7 per cent. manganese, with not more than 0·1 per cent.

Analysis of Iron Castings for Different Purposes.

Description.	Total Carbon.	Combined Carbon.	Silicon.	Manganese.	Sulphur.	Phosphorus.
	Per cent.	Per cent.	Per cent.	Per cent.	Per cent.	Per cent.
Bedplates	3.40	—	1.50	0.70	{ Less than 0.10 }	0.40
Chilled Castings	3.50	0.60	0.60	0.50	0.08	0.30
Cylinders—gas engine	3.25	—	1.50	0.80	{ under 0.08 }	0.30
„ hydraulic	3.35	0.70	1.00	0.90	{ under 0.10 }	0.30
„ locomotive	—	—	1.25	0.90	0.09	0.40
„ motor car	3.00	0.55	1.75	0.60	{ under 0.08 }	0.40
„ steam engine	2.90	0.90	1.50	0.80	{ under 0.09 }	0.40
Flywheels	3.50	0.40	1.75	0.60	{ under 0.08 }	0.50
Machinery—electrical	low	0.20	2.50	0.35	{ under 0.08 }	0.60
„ engineer's	3.60	0.60	1.25	0.90	{ under 0.10 }	0.40
„ medium	3.35	0.40	1.75	0.70	{ under 0.09 }	0.50
„ textile	—	—	2.00	0.60	{ under 0.08 }	0.60
„ trans- mission }	—	—	2.00	0.70	{ under 0.09 }	0.60
Ornamental work	3.28	0.08	2.50	0.60	{ under 0.08 }	1.00
Pipes	—	—	1.75	0.70	{ under 0.10 }	0.60

sulphur, the mixture to be composed of 2 parts pig to 1 of scrap, the latter of known composition, not exceeding the limits specified for the castings. Correcting for the changes which occur during melting, *i.e.*, allowing for 10 per cent. loss, the silicon content of the pig = *x* per cent. should be

$$\begin{array}{r}
 \text{pig} \quad \quad \quad + \quad \quad \quad \text{scrap} \quad \quad \quad = \quad \text{castings.} \\
 \left(2 \times \frac{x}{100} \times \frac{90}{100} \right) + \left(1 \times \frac{2}{100} \times \frac{90}{100} \right) = 3 \times \frac{2}{100}
 \end{array}$$

and $x = 2.33$ per cent. For checking the calculation it is convenient to employ the "cwt.-per cent." method. Thus, taking a charge of 15 cwts. composed of 2 parts pig and 1 part scrap, we should have 10 cwts. pig containing 2.33 per cent. silicon = 23.3 cwt.-per cent., and 5 cwts. scrap containing 2.00 per cent. = 10 cwt.-per cent. The silicon content of the mixture is therefore 33.3 cwt.-per cent. \div 15 cwts. = 2.22 per cent. As the loss in melting = 10 per cent., this will give 2.22 - 0.22 = 2 per cent. silicon in the castings, as required. Similar calculations show that the manganese may be increased to 0.88 per cent., whilst the sulphur content of the pig must not exceed 0.05 per cent. Suppose the phosphorus, which remains unaltered during melting, is not to exceed 1.25 per cent in the castings, which may also be taken as the limit in the scrap, and that it is proposed to obtain the required result by using a foundry pig containing 1.7 per cent. phosphorus, together with hematite containing 0.05 per cent. phosphorus. To determine the proportion of each, let x = quantity of pig, when $100 - x$ = quantity of hematite. Then

$$\begin{array}{rcccl} \text{pig} & + & \text{hematite} & = & \text{castings} \\ \left(x \times \frac{1.7}{100}\right) & + & \left\{(100 - x) \times \frac{0.05}{100}\right\} & = & 100 \times \frac{1.25}{100}, \end{array}$$

and $x = 73$ per cent., the hematite being, of course, 27 per cent. Testing now for silicon content, if analysis shows the foundry pig to contain 2.41 per cent., and the hematite 2.14 per cent., for the total pig in the mixture we have

$$\frac{(73 \times 2.41) + (27 \times 2.14)}{100} = 2.33 \text{ per cent.},$$

which agrees well with the amount required, as above. Similarly for manganese, the foundry pig was found to contain 0.3 per cent., and the hematite 0.87 per cent. Therefore for the total pig we have

$$\frac{(73 \times 0.3) + (27 \times 0.87)}{100} = 0.45 \text{ per cent.}$$

The content of manganese can be readily adjusted by the addition of the necessary amount of ferro-manganese to the ladle before casting. Silicon pig and ferro-silicon are used in the same manner to regulate the silicon content, and thus gain complete control over the composition of the mixture.

The complete calculation for a 15 cwt. charge would be as follows:—

Constituent.	Cwts. used.	Silicon.		Sulphur.		Phosphorus.		Manganese.	
		Per cent.	Cwt.-per cent.	Per cent.	Cwt.-per cent.	Per cent.	Cwt.-per cent.	Per cent.	Cwt.-per cent.
Foundry Pig . . .	7.3	2.41	17.59	0.05	0.50	1.70	12.41	0.30	2.19
Hematite . . .	2.7	2.14	5.78			0.05	0.135	0.88	2.37
Scrap . . .	5.0	2.00	10.00	0.10	0.50	1.25	6.25	0.70	3.50
	15.0		33.37		1.00		18.795		8.06
		$\frac{33.37}{15} = 2.22$ less 10% = 2.00		$\frac{1.00}{15} = .066$ + 50% = .099 (say) 0.1		$\frac{18.795}{15} = 1.25$ unchanged in melting = 1.25		$\frac{8.06}{15} = 0.53$ Allowing 15% loss in melting, 0.83 required to give 0.70 in castings. 0.83 - 0.53 = 0.3% to be added.	

CHAPTER XXIX.

AIDS TO MOULDING.—PLATE AND MACHINE MOULDING.

Oddside Moulding.—This is a device resorted to when a number of castings have to be made from an unjointed pattern, in order to save time in making the joint between the boxes separately for each mould. Working by the turn-over method, the pattern is temporarily embedded in the top box to enable the face of the joint to be cut at the proper depth. This is known as the oddside, and on it the bottom box is rammed up. The top box is then knocked out, and rammed up on the bottom box to the proper degree of hardness. The trouble of making the temporary joint every time may, however, be avoided by ramming up the bottom boxes of all the moulds required from the same oddside, which should then be made of a permanent character. This may be effected by stiffening the sand with linseed oil, which hardens somewhat on exposure to air, but plaster of Paris, with the face varnished in the same way as a pattern, makes the best permanent oddside.

Plate Moulding.—This follows as a natural development of oddside moulding. Wooden plates and patterns are sometimes used when the number of castings required is comparatively small. An example is given in Fig. 248, which shows the section of a *steam stop valve*, and its pattern mounted in halves, one on either side of the "plate," great care being taken that the two halves coincide exactly. If the pattern has been made in halves in the ordinary way, it is only necessary to lengthen the dowel pins to allow them to project through holes in the plate when perfect coincidence is easily secured. The plate is made to fit the moulding box pins, and to reduce wear, holes of the proper size are drilled through small metal plates secured to the board by wood screws. The plate is placed between the two parts of the box, and after ramming up the bottom box, the whole is turned over to complete the mould, the usual patterns for gate and runner

being inserted in the top box. The core is made in a box shown in Fig. 249, and a section of the complete mould is seen in Fig. 250. The objection to wooden plates is their liability to warp and twist, and for standard patterns, or where castings are frequently required in large numbers, both plate and pattern should be made in metal. This is the method now generally

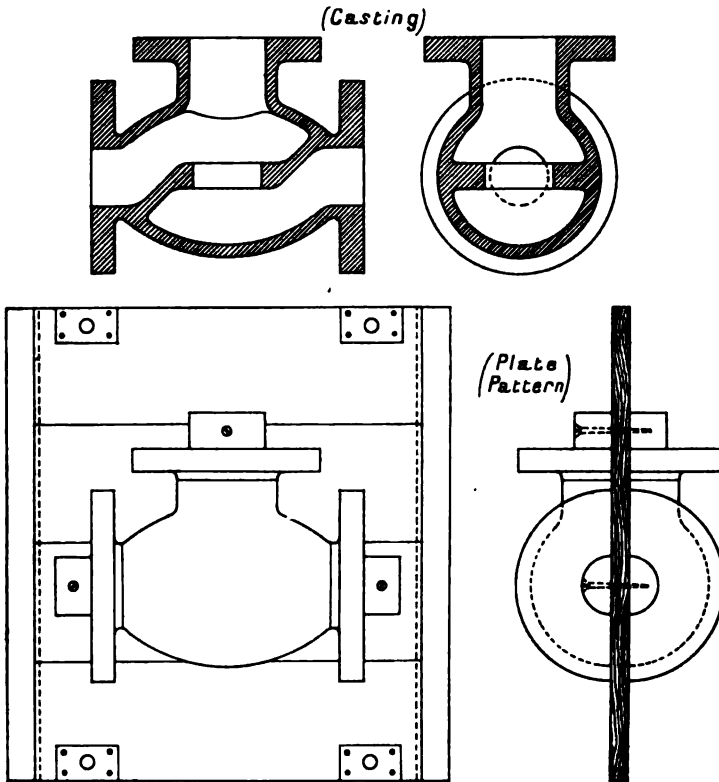

FIG. 248.—Plate Pattern for Steam Stop Valve.

adopted for gas and water fittings, and for many of the small articles made in such large quantities in the brass foundry. An example is given in Fig. 251, which shows the plate pattern for a "spray" of castings for the body of a small valve. The half patterns, which are of brass and carefully finished, are mounted symmetrically with respect to a central runner. The pattern for

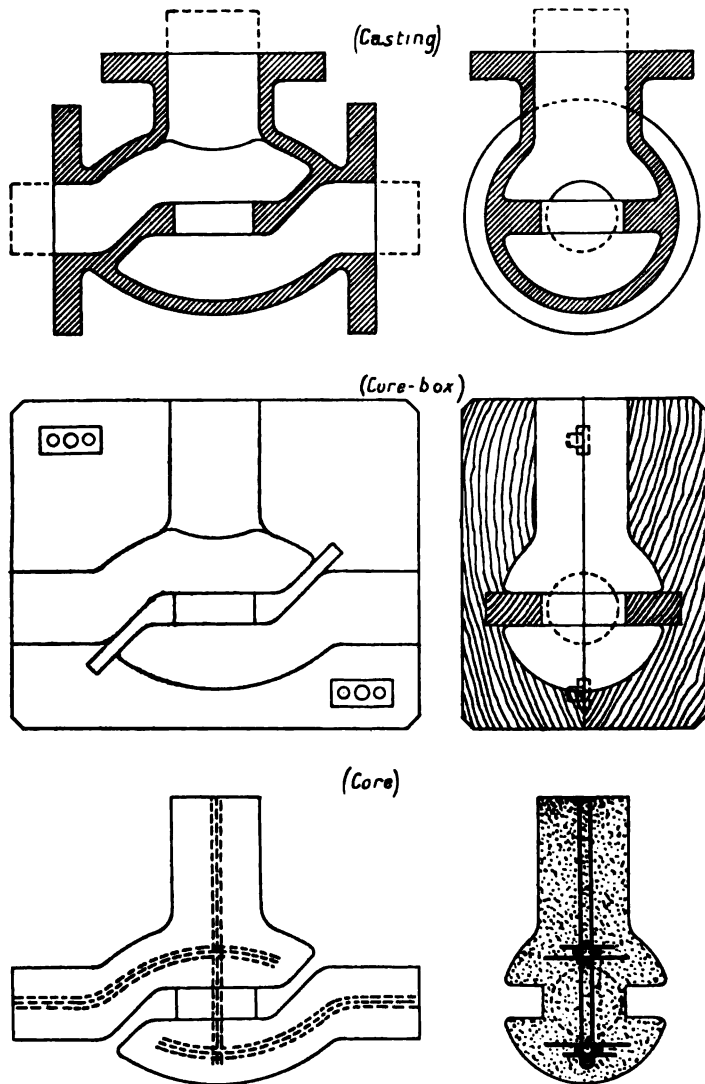

FIG. 249.—Core-Box and Core for Steam Stop Valve.

the latter, and also of the runners or channels communicating with each of the castings, are permanently mounted on the upper side of the plate (Fig. 252). With a plate pattern of this description, the labour of ramming is much reduced, and jointing

is entirely obviated. The great drawback is that the making of plate patterns, even for "easy" castings, is a very expensive process, as first-class workmen are required to obtain the neces-

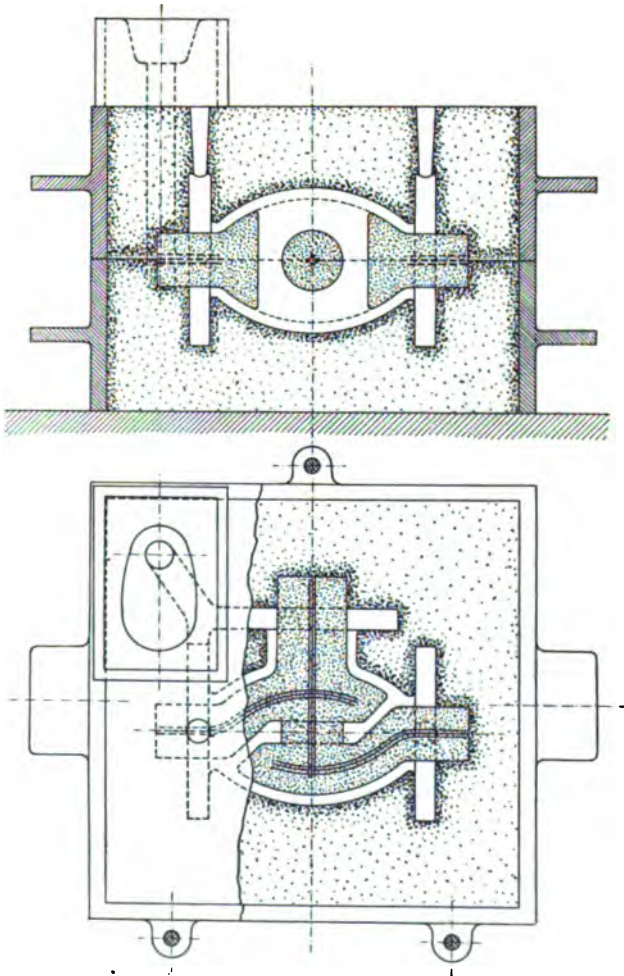

FIG. 250.—Complete Mould for Steam Stop Valve.

sary degree of accuracy. For any but the simplest and shallowest patterns, the separation of the flask and the pattern plate, or "drawing" the pattern, as it is termed, if performed by hand, requires some considerable degree of skill on the part of the

moulder to prevent the pattern rocking and breaking the edges just as it leaves the sand. Much time is spent in repairing moulds which have been damaged in this way, and it not unfrequently happens that a mould which has taken considerable time and labour to produce has to be abandoned. It is true that steady pins are sometimes screwed into the bottom box to assist in obtaining a vertical lift, but from this a step further leads to the employment of mechanism by means of which a positive and certain result may be ensured.

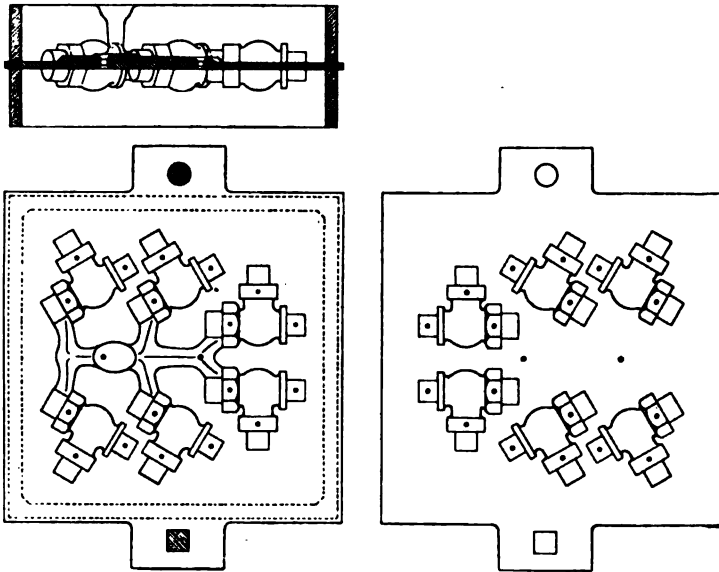

FIG. 251.—Plate Mould for Spray of Castings for Small Valve.

Machine Moulding.—The original purpose of the moulding machine was to enable the pattern to be drawn from the sand without risk of damage to the mould. At first, ramming was performed by hand as usual, but it soon became evident that some form of hand press, operated by a lever, could be applied for the same purpose. Hence moulding machines may now be classed under three heads: (1) machines which draw the patterns only, ramming being accomplished by the usual hand methods; (2) machines which are sometimes called “squeezers” which perform the ramming only, leaving the pattern to be

drawn by hand ; and (3) machines which both ram the moulds and draw the patterns, the ramming being effected either by hand lever, or fluid pressure on a piston. Of the first class of machine in which ramming is done entirely by hand, there are three distinct types depending upon the method employed for removing the boxes from the pattern plate. This may be

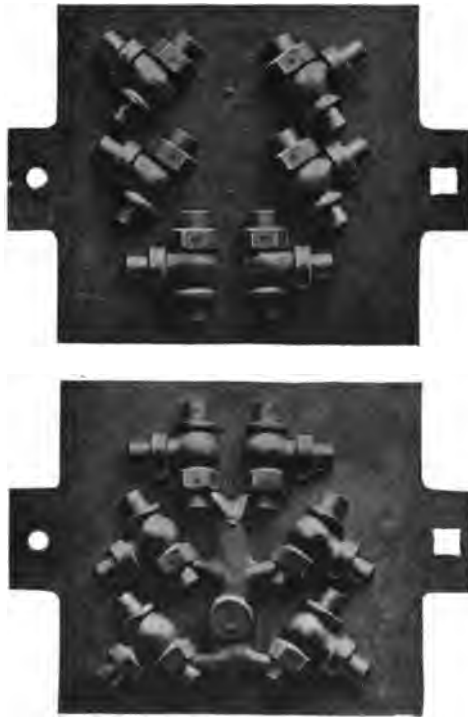

FIG. 252.—Plate Pattern for Spray of Castings for Small Valve.

effected (a) by a mechanical lifting device for raising the box, (b) by means of a "turn-over" table, and (c) by means of a "stripping plate." A *box-lifting machine* of the first type, as shown in Fig. 253, is suitable for small and light work. The moulding boxes are interchangeable, and by means of their pins come into register with the pattern plate, which is fixed upon the table of the machine. After the mould has been rammed by hand in the usual way, the box is lifted by four rods or "stools,"

which pass up through the table, and which are fixed in a movable frame capable of being raised by a foot lever. The machines are usually worked in pairs, for dealing with top and bottom boxes respectively. This simple machine is suitable for objects of no great thickness, but for deep moulding the *turn-over table machine*, Fig. 254, has some advantages. The pattern plates for top and bottom boxes are secured upon opposite sides

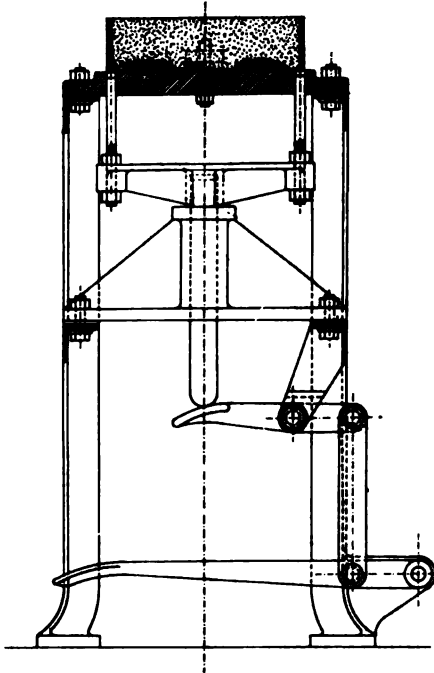

FIG. 253.—Moulding Machine of Box-lifting Type.

of the turn-over table, which can be rotated on trunnions through 180° , locking catches and clamping screws being provided to retain it in a truly horizontal position. A moulding box is placed in correct position over the pattern plate by means of centering pins, and is clamped or cotted to the upper side of the turn-over table. It is then rammed by hand, and the sand strickled off. The turn-over table is unclamped, rotated through half a revolution, and again fixed, the box now being on the under-side. By means of a rack and pinion motion operated by hand wheel through spur gearing, the lifting

table is raised to come in close contact with the box. The lifting table is provided with a drawing out table, or with a small carriage running on rails, which can be pulled out horizontally. It is upon the drawing out table that the box is made to bear, and in this position the clamps or cotters holding the box may be released, leaving the mould to be drawn from the pattern by lowering the lifting table until quite clear. The mould is then withdrawn from the back of the machine on the drawing out table or

carriage, and is removed by a labourer. The moulding of the bottom box, the pattern plate for which is now on the upper side of the turn-over table, is then proceeded with just as before. The same method of working is carried out in a much more mechanical manner in the *Pridmore rock-over drop machine*, Fig. 255, supplied by Messrs. J. W. Jackman & Co., Limited, of Manchester. The machine is shown engaged in moulding the body of a steam stop valve. In the position (*a*) the bottom box has been rammed up by hand as usual, and clamped to the rock-over frame, which gives the motion corresponding to the turn-over



FIG. 254.—Moulding Machine of Turn-over Table Type.

table in the last example. The weight of the box and mould is supported by two counterbalance springs, a second pair of springs being provided to facilitate the operation of rocking over. Both sets of springs are readily adjustable to suit the work in hand. The clamping frame is fitted with adjusting screws to take boxes of varying depth. Position (*b*) shows the frame rocked over, which has the effect of inverting the mould, the latter just coming to rest on adjustable stops on the drop frame. On releasing the clamping rod, the mould may be dropped away from the pattern by allowing the frame to slide down two vertical rods or guides under the action of a lever, position (*c*). The pattern is then rocked back into the original position, and the box raised ready

to be removed by a labourer, as seen in position (*d*). The methods just described, although well adapted for flat, shallow work, do not

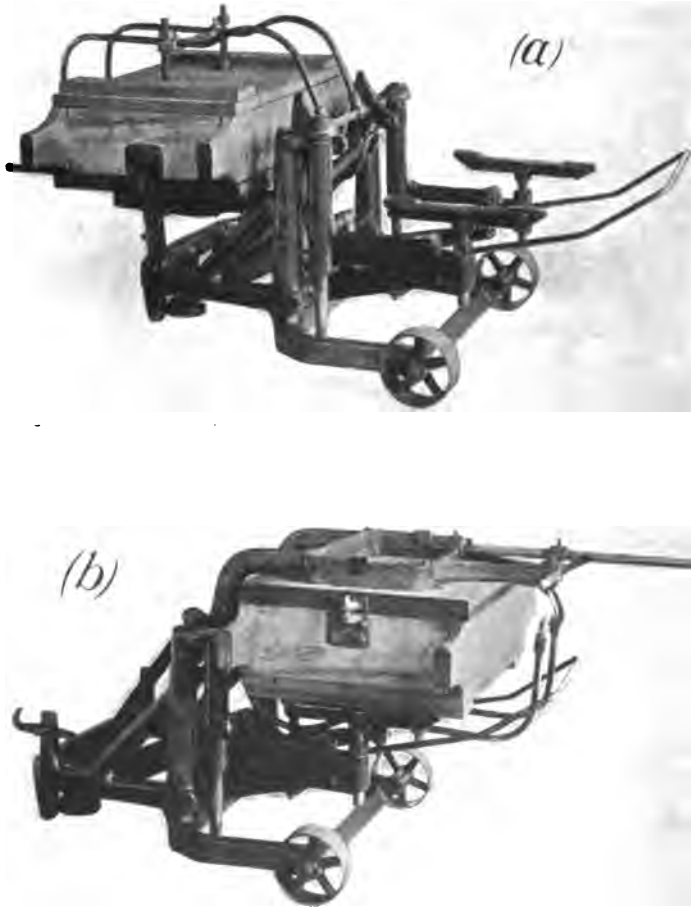

FIG. 255.—Pridmore "Rock-over Drop" Moulding Machine.

(*a*) Bottom box rammed up, and clamped to rock-over frame.
 (*b*) Frame rocked over, inverting mould.

lend themselves so readily to deep patterns with vertical sides, especially if the intervening portions of sand forming the mould should be very thin.

When drawing the pattern, the moulder adopts the plan of "rapping" the turn-over table with a wooden mallet, to over-



FIG. 255.—Pridmore "Rock-over Drop" Moulding Machine.

(c) Mould dropped from pattern.

(d) Frame rocked back, and mould ready to be lifted off.

come the adhesion of the sand to the pattern. This rapping, if vigorously performed, may cause the impression in the mould, and therefore the casting, to be appreciably larger than the

pattern. To overcome this defect, the stripping plate method of drawing patterns was introduced, the principle of which is shown in Fig. 256. In preparing the plate pattern, the pattern parts are raised from the plate by an amount equal to the thickness of the stripping plate. A hole of the exact shape of

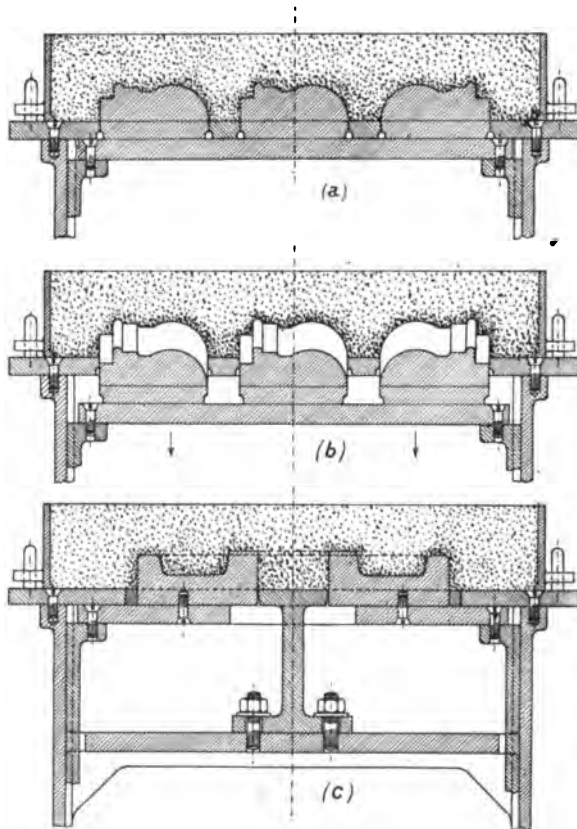

FIG. 256.—Stripping Plate Type of Moulding Machine.

the outline of the pattern at the joint surface is accurately cut through the stripping plate either by machinery or by filing. When the stripping plate has been placed in position upon the pattern plate, as at (a), the mould may be rammed up exactly as upon the ordinary pattern plate first described, but it will be seen that when drawing the pattern, as shown at (b), the

stripping plate remains behind, supporting the sand right up to the joint surface, thus preventing the possibility of breaking down or tearing the mould. The pattern need not be rapped at all, and as delivery takes place in a perfectly straight line, the mould is exactly "pattern size." The *Pridmore Stripping-plate Machine*, supplied by Messrs. Jackman, of Manchester, is a good example of this class. Two forms are shown in external elevation in Fig. 257. The base or pedestal of the machine takes the form of a frame open at the top, which may be of circular or other shape best suited to the work. Upon this is fixed the stripping plate, which is provided with pins to locate the moulding boxes in proper position. Inside the pedestal or stand is the drawing frame, which moves in vertical guides, and may be lowered by crank and connecting rod motion, operated by hand lever. The pattern plate is screwed down upon the drawing frame, which, for ramming, may be locked in the position shown. It will frequently happen that a mass of sand in the interior of the mould cannot well be carried on the stripping plate. One or more stools, or vertical pillars, placed where required, may then be employed to assist in supporting the sand, Fig. 256, c. They are secured to the stool plate, which forms part of, or is attached to, the frame of the machine, a space being left at each side through which the slides of the drawing frame can pass. The action of the stripping plate and stool will be seen from the second figure, which shows the pattern plate dropped clear of the mould. The stripping plate method is particularly suitable for spur wheels and for pulleys or other articles to be cast without "strip," i.e., with perfectly vertical sides. It is true that considerable expense may be incurred in the preparation of stripping plates by machining out of solid, and however fine the joint between pattern and stripping plate, sand finds its way in, causing more or less rapid wear and deterioration. In the majority of cases, however, the stripping plate may be cast with an opening approximately following the actual shape of the pattern, and about $\frac{3}{4}$ inch clear all round. After planing the surfaces of the stripping plate, it is adjusted in position on the pattern plate, and the space filled in with white metal (see Fig. 256, c), which forms an accurate fit, easily renewable by re-melting when any appreciable wear of the edges has taken place. *Power ramming,*



FIG. 257.—Pridmore Stripping Plate Moulding Machine.

actuated by hand lever, compressed air, or hydraulic pressure, may be used alone or combined with the pattern-drawing device of one of the three types of machine just described. A well-



FIG. 258.--Farwell Hand Press Moulding Machine.

known example of *hand press moulding machine*, or "squeezer," is the Farwell, Fig. 258, made by the Adams Company, of Dubuque, U.S.A. The ordinary form of plate pattern with parts on both sides of the plate is generally used with this machine, the pattern being set between the two boxes, which are placed on the table

of the machine, bottom box upward. Sifted sand is then filled in, and the bottom board placed squarely upon the mould. The bottom board is $\frac{1}{4}$ inch smaller each way than the inside of the box, so that it may enter the box when the sand is compressed. The boxes are now turned over, the top box filled with sand, and the presser board (which is of the same size as the bottom board) placed in position. The presser head is carried on adjustable side rods, and can be swung back out of the way when filling the boxes. It is operated by a lever mechanism, one movement of which brings the presser head forward immediately

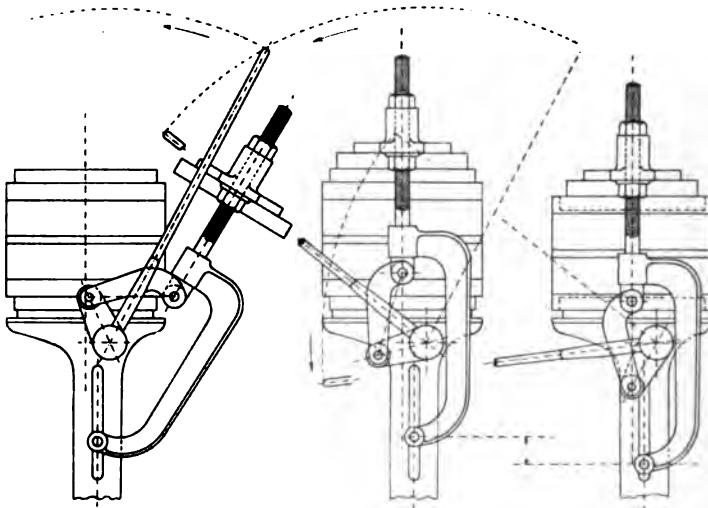

FIG. 259.—Presser Head Mechanism of Farwell Moulding Machine.

over the box, and then pulls it down to apply the pressure to the mould, the final squeeze being administered *with the hand lever in a horizontal position*. This is an important feature, as the operator is enabled to utilise his weight to full advantage with the least possible muscular exertion. The action of the presser head mechanism is shown in the three positions of Fig. 259. In the example shown, lifting is done by hand when separating the mould, but the Farwell machine may be fitted with a lifting device, or may be used with a stripping plate if required. Such machines are well adapted for thin work, and are much lower in first cost than those actuated by fluid pressure.

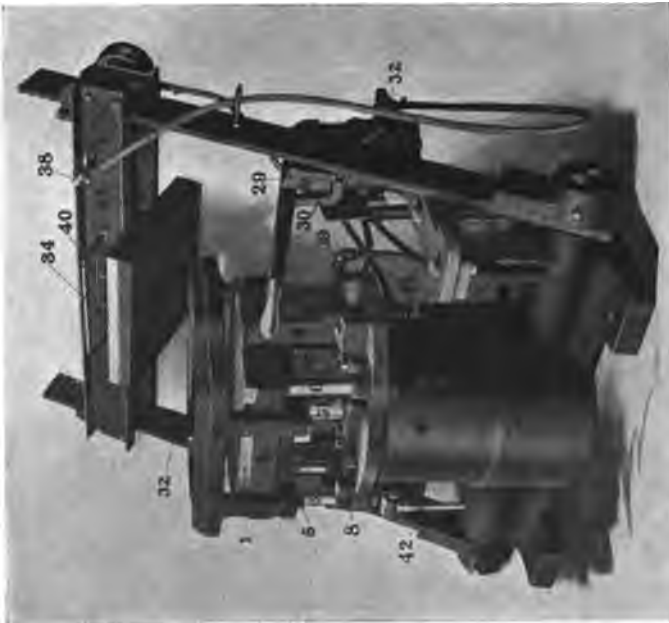
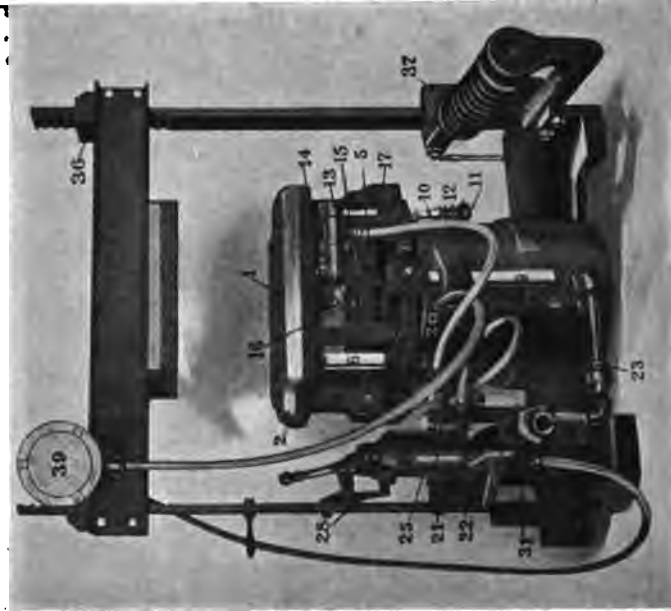

FIG. 260.—Front and Back Views of Tabor Pneumatic Moulding Machine.

For larger and heavier work, machines operated by compressed air or hydraulic pressure are to be preferred. One of the most successful of the *pneumatic machines* is that of the Tabor Company, of Philadelphia, U.S.A., supplied by Messrs. Jackmans, Ltd.,

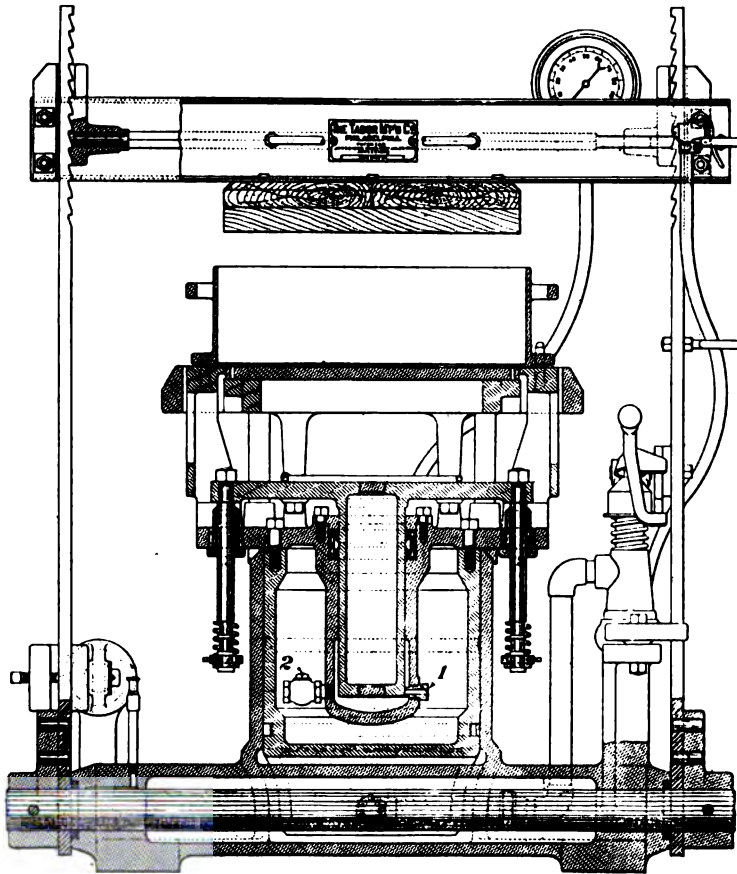

FIG. 261.—Section of Tabor Pneumatic Moulding Machine.

of Manchester, of which two external views and a section are given in Figs. 260 and 261 respectively. The squeezing piston, to the top of which the ramming head, 7, is attached, works with an air pressure of from 60 to 80 lbs. per square inch. A pressure gauge, 39, registers the pressure applied, so that when once the correct pressure for any particular mould has been determined, uniform

density of ramming may be ensured. The squeezing piston (Fig. 261) contains the smaller or pattern-drawing cylinder, and being hollow, forms an oil tank, which is kept full of thin hydraulic oil. The height of the yoke or presser head, 33, is adjustable for flasks of different depths by means of ratchet teeth, 36, in the strain bars 32 (see also Fig. 261). The yoke, being too cumbersome and heavy to be moved by hand, is swung backwards and forwards as required by power, for which purpose an air cylinder controlled from the valve stand is provided. Various methods of mounting patterns may be adopted with the Tabor machine, but an important feature is the use of a *power-driven vibrator*, 13, applied directly to the plate carrying the patterns, which are thus vibrated independently of the other parts of the machine. The vibrator, shown in section in

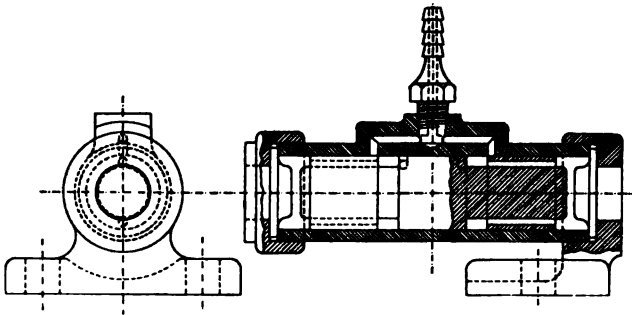

FIG. 262.—Vibrator for Tabor Moulding Machine.

Fig. 262, consists simply of a long double-acting piston, having a stroke of about $\frac{5}{16}$ inch, working automatically in a valveless cylinder, upon hardened anvils at each end of which blows are delivered at the rate of 5,000 per minute. In order to communicate these extremely rapid, yet small, vibrations to the pattern without at the same time transmitting them to the rest of the machine; the pneumatic vibrator is bolted direct to a frame, called the vibrator frame, seen at 4, in Fig. 260, and shown separately in detail at Fig. 263. To this frame the pattern plate, 1, is fastened by four screws, the tapped holes for which are shown in the corners. The vibrator frame itself is secured to the machine structure by four large bolts, which pass through thick bushings in the inner corners. The bushings are sufficiently elastic to absorb the vibrations of the frame and

pattern, whilst at the same time they are well fitted and firm enough to hold the pattern accurately to its position. The action of the vibrator may be compared to an exceedingly violent shiver over the whole surface of the pattern, making it impossible for any sand to adhere, and yet the pattern is so little disturbed from its original position that it is impracticable to draw it a second time without rapping. A gas burner, 15, is provided on the stool plate, 5, to warm the pattern if necessary should the sand show signs of sticking. To operate the machine, a half flask is put in position over the pins in the flask frame, 2, parting sand shaken on the pattern, and the flask filled with sand. The yoke

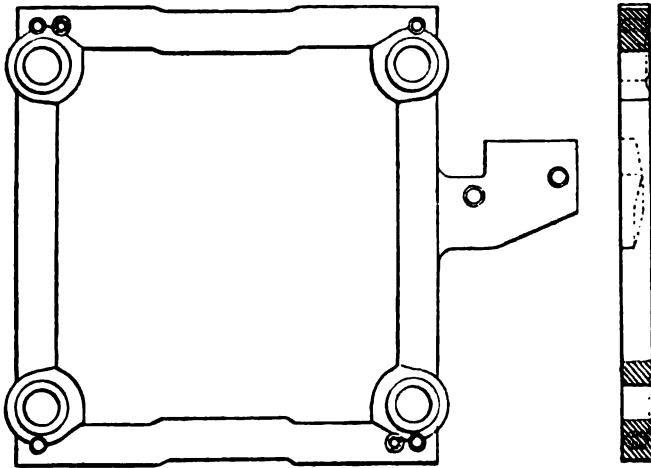

FIG. 263.—Vibrator Frame of Tabor Moulding Machine.

is then moved forward, and pressure applied to the mould by pressing down the operating lever, 27, thus opening the throttle valve and admitting compressed air to the squeezing cylinder until the gauge indicates that the correct pressure has been reached. On releasing the valve lever, the squeezing piston and parts connected to it resume their normal position, and the yoke may be moved back. The pattern is drawn by raising the operating lever, thereby admitting compressed air to the oil tank, and forcing the oil through a nipple near the bottom of the pattern-drawing cylinder. The nipple almost touches the piston, thus admitting the oil slowly until the end of the piston uncovers

the nipple, when a full opening is maintained until the end of the upward stroke. This gives a slow draw until the mould is clear of the pattern, followed by a rapid lift for the remainder of the stroke. When the operating lever is raised to draw the pattern it also starts the pneumatic vibrator, to loosen the pattern in the sand while the mould is being lifted. When the drawing piston begins its downward stroke, the check valve opens, permitting a quick return. The nipple, when it is reached by the piston, partly shuts off the flow of the oil, giving a cushioning effect at the end of the stroke, and the possibility of shock at the end of the draw is eliminated by buffer springs on the flask frame stops, 10. A supply of compressed air, 38, is available for blowing off any sand from the pattern after it has been drawn.

Bonvillain and Ronceray's System of Moulding.—An example of a machine operated by hydraulic pressure may now be referred to, including some description of a novel system of moulding developed by Messrs. Bonvillain and Ronceray of Paris, and introduced into this country in much-improved form by Messrs. Greenwood and Batley, Ltd., of Leeds. The expense of metal patterns and stripping plates has always proved a great obstacle to the extended use of machine moulding, and has only been warranted when several hundreds, or even thousands, of a given article were to be produced. On the Bonvillain system, the preparation of pattern plates has been so much simplified and cheapened that the method can be profitably adopted when the number of castings required does not exceed from 50 to 100. The employment of white-metal and plaster in place of brass or iron, enables the moulder to manufacture his own plate patterns and stripping plates on this system without calling in the assistance of the fitting shop. Three different methods of procedure are employed in carrying this idea into effect:—

- (1) The reversible pattern plate, with or without stripping plate.
- (2) The double pattern plate, with or without stripping plate.
- (3) The reversible "cliché" process.

In the preparation of a pattern by the first method, two exactly similar boxes are required. Taking, for example, a simple article such as Fig. 264, this is moulded from an ordinary wood pattern in such a manner that the parting coincides with

the line *ab*. After lifting off the top box and drawing the pattern the two boxes are laid side by side in exact position and clamped

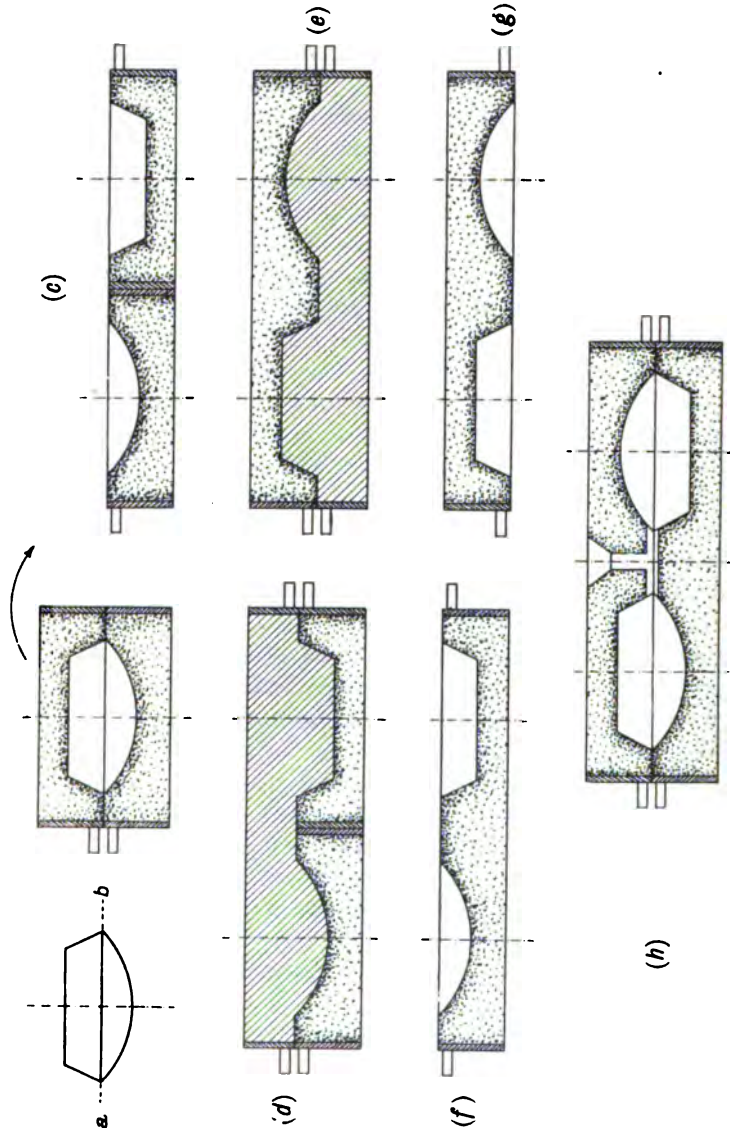

FIG. 264.—Bonvillain System of Moulding.—Reversible Pattern Plate.

together (c). A rectangular frame of the proper size to fit over both boxes is placed upon them, and is filled up level with

plaster (*d*). This, when set, may be removed bodily with the frame, and constitutes the reversible pattern (*e*), from which both top and bottom boxes are moulded. Thus, in the manner shown in (*f*) and (*g*), two exactly similar impressions are taken, one of which (*f*) becomes the bottom box and the other (*g*) the top box. These, when placed together, give the complete mould (*h*). In this way, one pattern plate without any change whatever serves to produce a complete mould on one machine. Further, it will be seen that when two half moulds are rammed on the same pattern plate, and are placed one above the other so that their axes coincide, but reversed relatively to each other, the number of castings obtained will be twice the number of patterns employed. This means a great increase in production with very little increase in cost, either of plant or labour.

If more than 100 castings of the same pattern are required, it is advisable to use a metal pattern plate which is easily produced by the following process, Fig. 265: From a plaster pattern plate, obtained exactly as just described, two half moulds are rammed up in sand. One of these is carefully sleeked and smoothed over, and from the other a thin layer of sand is removed, as shown in dotted lines, following the form of the surface as nearly as possible, although it is by no means necessary to preserve an absolutely uniform thickness in all parts. The two half moulds are now put together, and the space between them filled by pouring in a special white metal alloy, which does not contract to any appreciable extent on cooling. In this way, a hollow metal pattern is obtained, which is placed in a suitable cast iron frame, and the latter filled up level with plaster. The method of producing stripping plates on the Bonvillain system is very ingenious. A reversible pattern plate in plaster is prepared as already described, and from this two half moulds are rammed up in sand. Before, however, proceeding to ram up the second half mould, a sheet of soft indiarubber is placed upon the plaster pattern. The rubber varies in thickness from $\frac{3}{8}$ to $\frac{5}{8}$ inch, according to the size of the mould, and it is of a quality which readily adapts itself to the shape of the pattern. When the box has been rammed, the rubber sheeting is removed, leaving a hollow space in the completed mould, which is filled with white metal alloy. It may now be said that a hollow pattern has been obtained in combination with its stripping plate, and it only

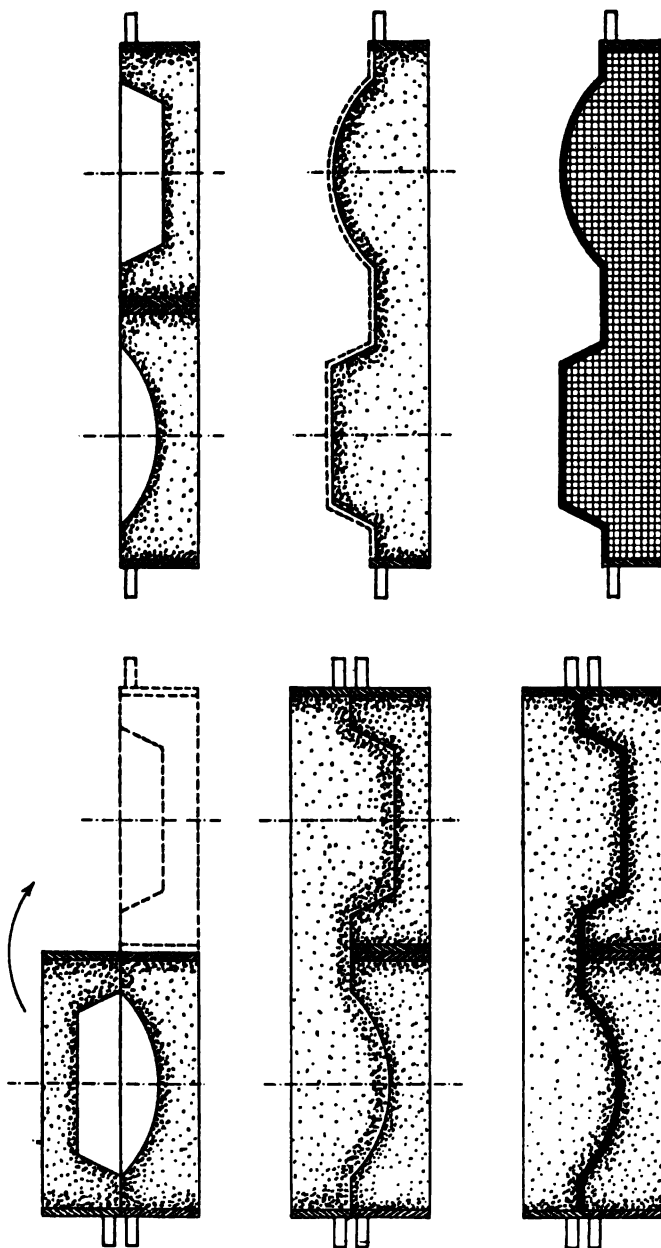

FIG. 265.—Bonvillain System of Moulding.—Production of Metal Plate Pattern.

remains to separate one from the other. It will be noticed from Fig. 266 that at certain points, *a*, the thickness may be reduced by scraping away the corner, when by means of a sharp knife the pattern, 1, may be severed from the stripping plate, 2, by cutting along the line A, shown in plan. An example is given in Fig. 267, which represents the reversible pattern plate and stripping plate for a half bearing, and shows the spray of castings produced. Six half bearings appear on the pattern plate, but by the "reversible" arrangement, twelve are obtained in the final casting. A great advantage of this method is that the pattern and stripping plates are not confined to flat, or nearly flat joints, but on the other hand, the parting may follow any convenient direction whatever, and in the case of intricate work, two or more stripping plates may be used with one pattern plate. The double pattern plate process is employed for very deep or hollow castings. The pattern plates are made by a copying scheme similar to that used for the reversible plates, except

that one part of the pattern is placed on one plate, and the other part on another, corresponding to the top and bottom boxes respectively. This involves the use of two moulding machines, one for each of the pattern plates, the two boxes being afterwards assembled on the foundry floor. An example of *double pattern plates* is shown in Figs. 268 and 269. Fig. 268 is the plaster mould prepared for the construction of the pattern plate for one side of a four-cylinder petrol motor crank-case. Fig. 269 shows the double pattern plate for the other side of the casing, with stripping plate and loose pieces separated from pattern.

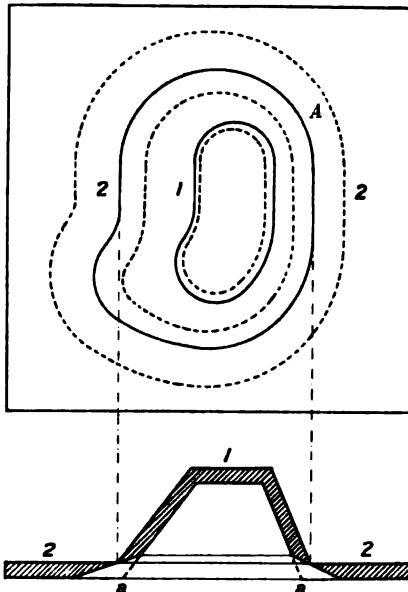

FIG. 266.—Method of producing Stripping Plate on Bonvillain System.

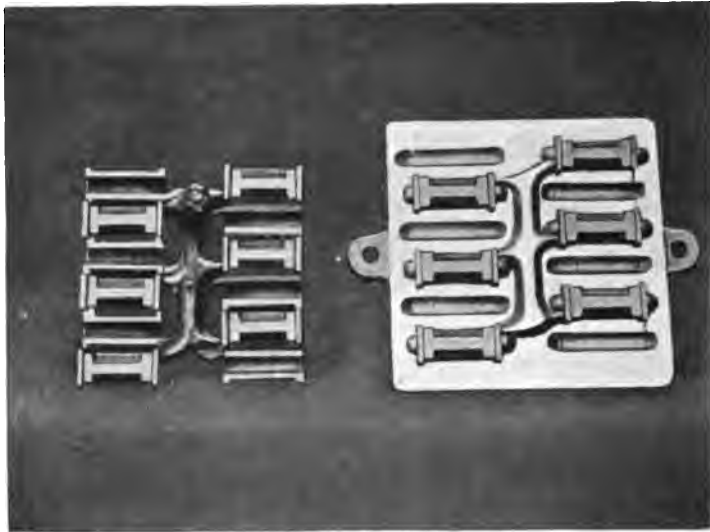

FIG. 267.—Reversible Pattern Plate and Stripping Plate for Half Bearing, and Spray of Castings produced.



FIG. 268.—Plaster Mould for Pattern Plate of Petrol Motor Crank Case.

Fig. 270 shows the same pattern with stripping plate and loose pieces in position, the projecting lugs of the stripping plate by means of which it is lifted in the machine being clearly visible. The "*cliché*" process has been derived from the reversible plate process, and has the same general features. It is especially useful for small, flat articles which have to be produced in very large quantity. The "*clichés*" are small reversible pattern plates of white metal, each produced in precisely the same way as the larger reversible plates. They are all of exactly the same

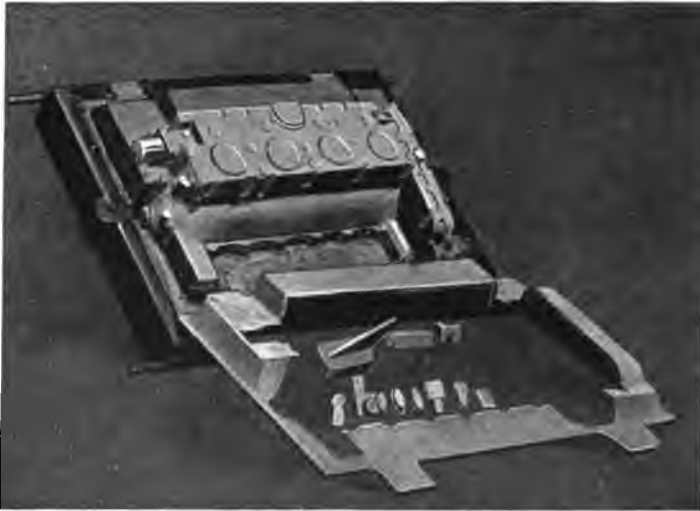

FIG. 269.—Double Pattern Plate, Stripping Plate and Loose Pieces of Petrol Motor Crank Case.

size and thickness, and are arranged to slide side by side in a special frame, called the *cliché* table, in which they are secured by clamping screws, as seen in Fig. 271. The whole, on being assembled, forms one complete pattern plate, the two sides of which, being exactly alike, may be moulded on one machine. On the left of Fig. 272 is shown a "spray" of small bracket castings, with the sectional reversible *cliché* plate from which they were moulded on the right. One hundred and sixty of these castings were produced per hour by an unskilled man on a hand lever moulding machine. For the smaller and lighter work, a hand lever moulding machine, Fig. 273, is used in connection



FIG. 270.—Double Pattern Plate for Crank Case of Petrol Motor.



FIG. 271.—Bonvillain System of Moulding. The Cliché Process.

with this system. The pattern plate is fixed upon the table of the machine, and upon the plate the flask is placed and filled with sand in the usual way. The ramming is done by a ramming board carried on a swinging presser-head above the table, and actuated by a hand lever through a toggle motion which gives a heavy pressure just at the bottom of the stroke. The stripping cylinder is fixed below the table, and to the ram is attached the stripping table, which carries four adjustable rods engaging with lugs on the stripping plate. The ram is actuated by oil

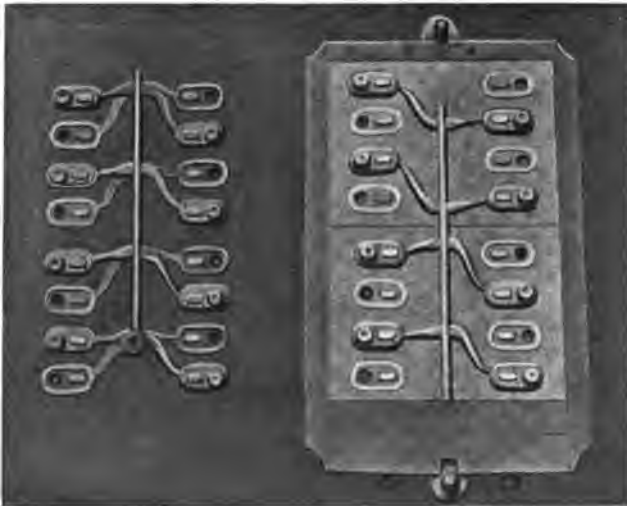

FIG. 272.—Reversible Cliché Plate and Spray of Bracket Castings.

forced into the cylinder by a small hand-pressure pump, the plunger of which is provided with a pedal head. On the completion of ramming, the moulder releases the hand lever, when the ramming-head rises and swings back into its angular position under the action of two helical springs. The pump plunger is then pressed down, forcing the oil into the stripping cylinder. This raises the ram and with it the stripping plate, which carries the flask with it, and strips the pattern. In the figure, the stripping plate has just been lifted, and with the flask has been removed to show the rods more clearly. When the pressure upon the plunger is released, the stripping ram and stripping plate descend, ready for another flask to be

placed in position, and the operation is repeated. For larger machines, Messrs. Bonvillain and Ronceray have adopted hydraulic in preference to pneumatic pressure, on account of the perfectly steady movement obtained either in ramming or in pattern drawing, the absolute control over the total pressure



FIG. 273.—Bonvillain Hand Lever Moulding Machine.

applied, the small diameter of the rams, and the small amount of power required to work the machines. Messrs. Greenwood and Batley state that 3 H.P. is sufficient to work six moulding machines, and that this is about six times less than that required for compressed air doing the same work. It is also

claimed that the first cost and maintenance of a hydraulic plant will compare favourably with that for compressed air. The *Universal Moulding Machine*, Fig. 274, is provided with a hydraulic power head, *a*, which swings in and out of position upon a hollow column, *f*, attached to the side of the table, *e*.

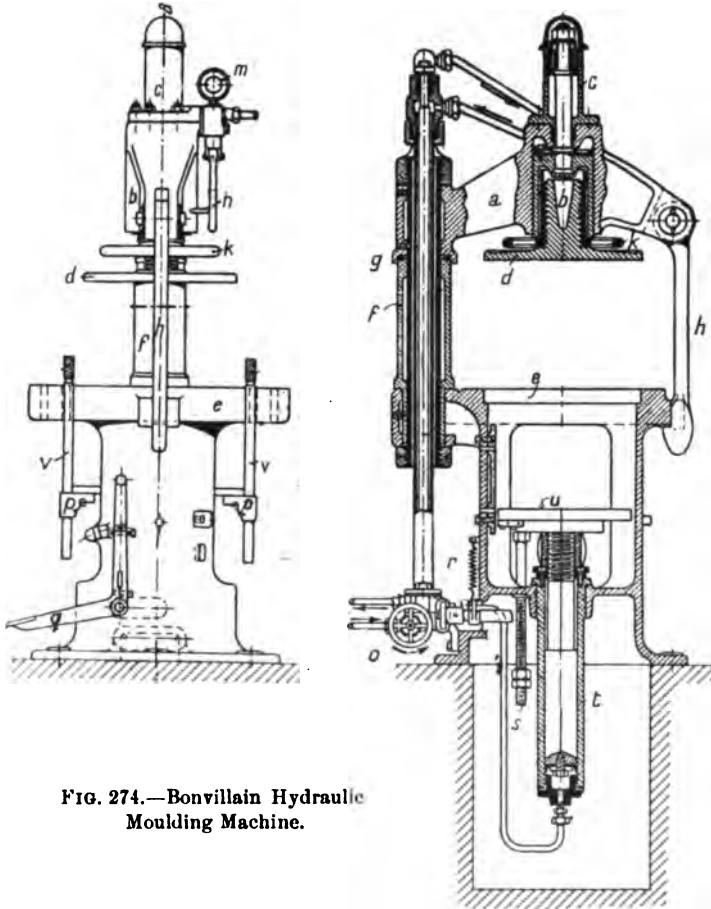

FIG. 274.—Bonvillain Hydraulic Moulding Machine.

The head swings on ball bearings, *g*, to give an easy movement, and when the pattern plate is being set or the flask filled, the head is swung out of the way behind the machine. To avoid bending stress on the column, a hook, *h*, at the front end of the arm engages in a slot in the table when the head is brought back into position for ramming. In the centre of the arm is formed

the ramming cylinder, *b*, in which works the ram connected to the ramming plate, *d*. To give a ready adjustment of the distance between ramming plate and pattern plate, and thus accommodate moulding boxes of varying depth, the power ram is fitted with an arrangement of double screw and hand wheel, *k*, shown in detail in Fig. 275. The stroke of the ram need not, therefore, exceed from $1\frac{1}{2}$ to 2 inches, no matter what the size of the flask may be, and the quantity of water consumed is consequently very small, amounting to not more than 4 pints for a flask 16 inches square. The working pressure of 750 lbs. per square inch is admitted to the ram by a valve, *m*, and hand lever, *n*, on one side of the swinging head, pressure and exhaust passing from the main valve, *o*,

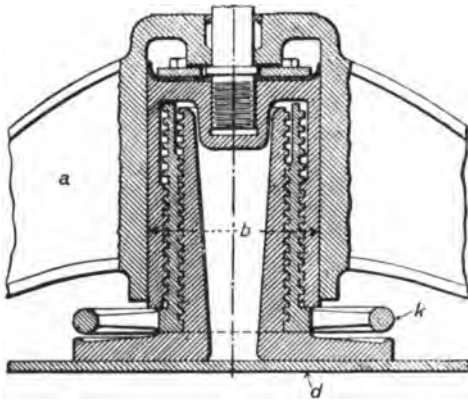

FIG. 275.—Bonvillain Moulding Machine.
Adjusting Screw.

fixed to the base of the machine, through annular pipes contained in the hollow column. After ramming, the power ram is returned to its original position by a constant pressure piston fixed to a tail-rod on the ram and working in a small cylinder, *c*, attached directly to the top of the main cylinder. The pressure and exhaust pipes,—the former placed inside the

latter,—lead down to a stop valve, *o*, situated at the back of the machine for controlling the supply to both ramming and stripping cylinders. The stop valve is arranged in the same casing as the control valve for the stripping cylinder, and the latter is operated by a foot pedal, *q*, in front of the machine to allow of the workman having both hands free while stripping is in progress. The pedal returns to the off position under the action of a spring when released, so that the ram commences its downward stroke while the flask is being removed, no time being lost. A screw stop, *s*, is fitted to keep the ram at the top of its stroke when necessary. The stripping action is performed by an oil

cylinder, *t*, fixed in the base of the machine, exactly as described for the hand lever machine. The stripping table, *u*, attached to



FIG. 276.--Bonvillain Hydraulic Moulding Machine.

the ram is provided with stool brackets, *p*, carrying adjustable stools, *v*, for engaging under the stripping plate. The stripping ram is made adjustable in its stroke by suitable rods and nuts, *r*, to give an exact movement to the stripping plate in accordance

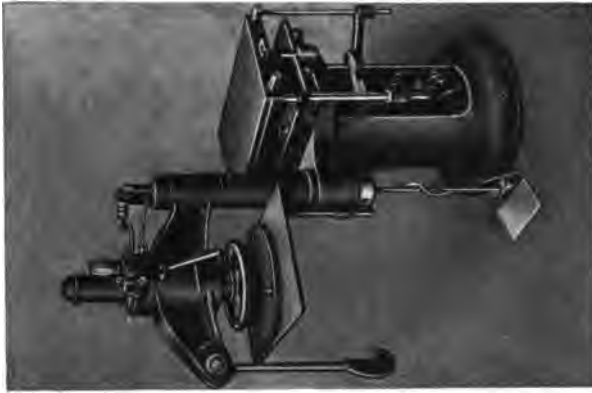

FIG. 279.—Bonvillain Moulding Machine,
with Power Head Swung to Rear.

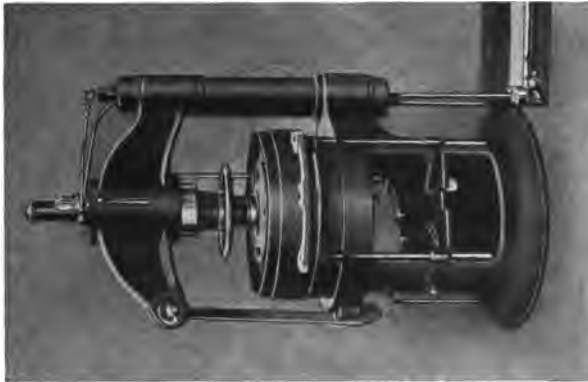

FIG. 278.—Bonvillain Moulding Machine
after Ramming.

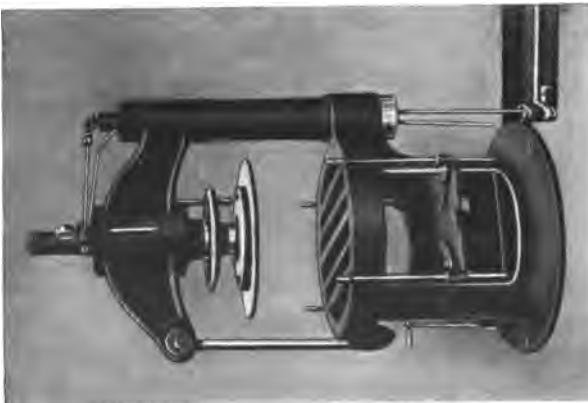

FIG. 277.—Bonvillain Moulding Machine
without Pattern Plate and Flask.

with the pattern. In order to facilitate work with these machines, a swinging sand-filler (Fig. 276) is usually fitted. This consists of a piece of hoop iron bent to the shape of the flask and arranged to swing on the vertical column of the machine. The filler is made of such a depth that when in position over the flask, it forms a gauge indicating the amount of sand to be filled into the flask before ramming. After filling in sand level with the top of the filler, the ramming plate may then be brought down inside it, the filler being swung back out of the way when ramming is completed. The foot pedal is then pressed down, stripping the pattern and leaving the finished mould to be lifted off. The machine is shown in Fig. 277 without pattern plate and flask, in Fig. 278 with flask and sand-filler in position after ramming is completed, and in Fig. 279 with the power head swung round to the rear, the stripping plate raised ready for lifting off flask. Fig. 276 also shows the double ramming device for use where deep cores and recesses are to be made in greensand. This is operated by a foot pedal located in front of the machine, which engages in a socket and gives when necessary an additional pressure from below to certain parts of a mould while still under pressure from the top, as, for instance, in the case of deep core holes. The upward pressure is limited as to stroke by means of a stop which engages the stripping ram pedal. It is often possible in this way to form the cores at the same time as the rest of the mould, the trouble

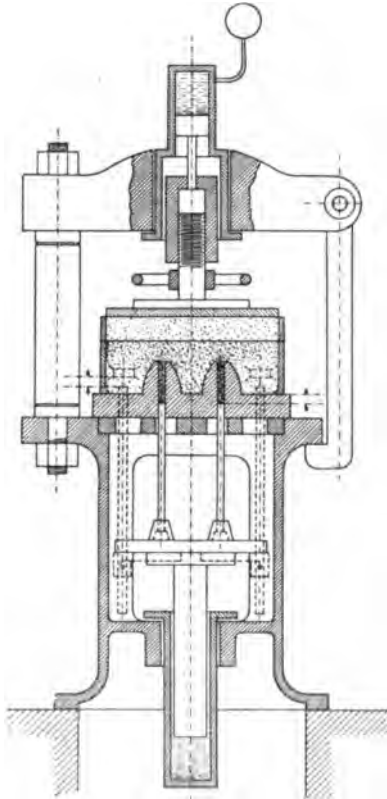

FIG. 280.—Bonvillain Moulding Machine, with Double Ramming Device.

of core-making being avoided, and the possibility of any movement prevented. The arrangement is shown in Fig. 280, which is a section through the lower part of the machine. The pattern plate rests directly upon the table of the machine, and in this case the pattern has no core-prints, but is an exact copy of the article to be moulded. The flask rests directly upon the pattern plate as usual, and the long thin cores, $\frac{3}{4}$ inch diameter and 3 inches long, are formed in the holes in the bosses, as shown. A plate, adjustable as to height, is carried on the top of the stripping ram independently of the stripping plate already described. In this plate, plungers or stools of the exact size of the holes to be cored out are fixed, and are made of such a length that a slight compression of the sand forming the core takes place before the stools come in contact with the stripping plate. As the motion continues, the pattern is stripped as usual, but the rods supporting the cores move at exactly the same rate, passing completely through the holes in the pattern until the sand is lifted quite clear.

Difficulties in Machine Moulding.—It may be said that flat-shaped patterns of no great depth, or even deep patterns with well-rounded or sloping sides, can be dealt with quite easily by almost any type of machine. Patterns of irregular shape, with some parts deeper than others, give rise to some difficulty. With machine ramming, the sand is always denser near the presser head than it is in the immediate neighbourhood of the pattern, although, as a rule, the reverse should be the case. Hence hand ramming is sometimes resorted to for the lower part of the mould, the bulk of the sand being afterwards put in by the machine. A device termed a "contour-head" is often used with the same object. For ordinary work, the presser-head is left flat on the underside, but when dealing with deep or uneven shapes, a block of wood,—the contour-head,—roughly carved to follow the outline of the pattern, is employed to effect a uniform distribution of pressure upon the sand. Again, objects with parts projecting out laterally are difficult to mould by machine, and if cores are not used, these parts must be rammed by hand. Very deep and intricate moulds, or moulds having perpendicular sides, require special precautions with almost all machines of the types already described. This has led to the introduction of the "jolt" or "jar-ramming" machine, which, although

such a striking innovation, has achieved a remarkable success. The principle upon which the machine is constructed is shown in Figs. 281 and 282. The table, *a*, upon which the pattern and mould are placed, is subjected to a rapid shaking action,

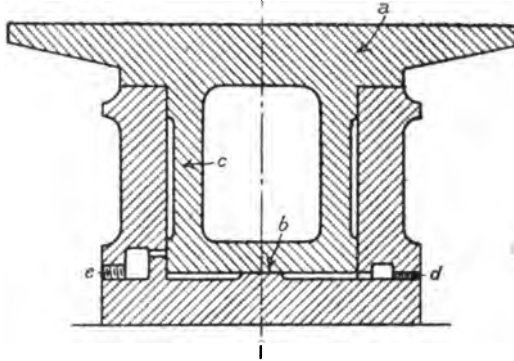

FIG. 281.—Principle of "Jar-ramming" Moulding Machine.

which in a short time causes the sand to "pack" very densely, and no ramming, in the ordinary sense of the term, is required. The jarring table is lifted by compressed air at a pressure of

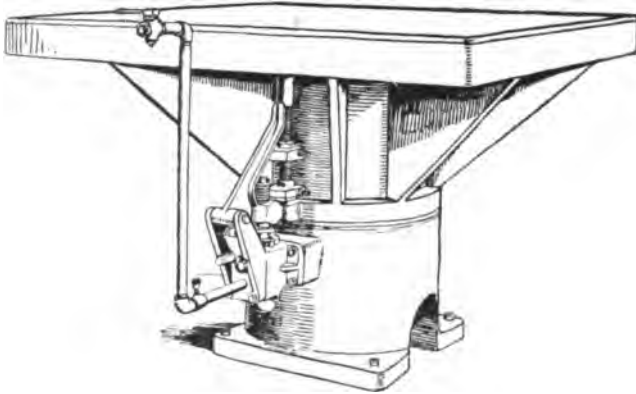

FIG. 282.—Tabor "Jar-ramming" Moulding Machine.

about 80 lbs. per square inch, and is then allowed to fall upon an anvil, *b*, the height of drop varying from 1 to 5 inches, according to the weight of the mould. The rate of working is about 120 "jars" per minute, and it is found that after some 15 or 40 jars have

been given, no further increase in density can be obtained. The action is rendered automatic, as will be seen from the figure, by permitting the ram, *c*, attached to the jarring table to overrun the exhaust port, *e*, when the supply of air at *d* is cut off, and the fall takes place, a blow being delivered upon the anvil which forms the base of the machine. At the bottom of the stroke the ram again closes the exhaust port, air is re-admitted, and the action repeated. It was soon found that if an actual blow be delivered, damage to the machine would speedily result, and the noise and vibration might prove to be a nuisance to the neighbourhood.

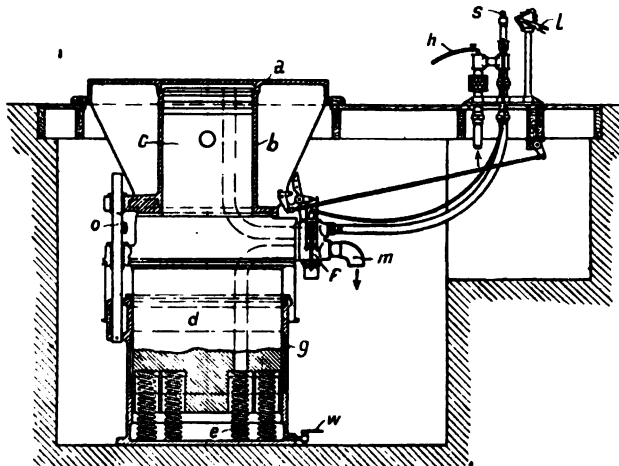

FIG. 283.—Section of Tabor "Jarring" Moulding Machine.

An important step was to recognise that, even at some loss of efficiency, actual shock must be avoided by cushioning the moving parts at the end of the stroke. This led to the development of the Tabor "shockless" jarring machine, an example of which, supplied by Messrs. Jackmans, Ltd., of Manchester, is shown in section in Fig. 283. The jarring table, *a*, which is strongly ribbed to resist the constant shocks to which it is subjected, is cast in one piece with the cylinder, *b*, in which the jarring ram, *c*, works. The latter is mounted upon a massive cylindrical anvil, *d*, which is supported on springs, *e*, and is capable of a slight vertical movement within the cylindrical base of the machine, *g*. Compressed air is first admitted to the ram, raising the table and its

load, and at the same time pressing down the anvil. At a certain point in the upward stroke, the admission of air is cut off automatically by the valve gear, the remainder of the stroke being performed by expansion. The valve now opens to exhaust, and the air, before escaping into the atmosphere at *m*, is first passed into the anvil cylinder through the port shown. The table falls by gravity, sliding on the jarring ram, and the anvil is thus relieved momentarily of its load. The springs on which the anvil rests therefore expand, and together with the pressure of the exhaust air, raise the anvil upwards to meet the descending table. The jarring cylinder and anvil are now moving towards each other, and at the moment of impact the momentum of the falling cylinder and table is equal to that of the rising anvil. The effect of the blow is therefore utilised almost without diminution for "packing" the sand, without transmitting shock or vibration to the machine and its foundation. The admission of the exhaust air to the anvil cylinder has the further advantage that the motion of the anvil is accelerated, whilst at the same time the table is retarded. The table thus remains in close contact with the pattern plate and the mould, and the rebound, which might injure the mould, is avoided. The machine is set in motion by the hand lever, *s*, which admits air to the automatic valve, *f*. A second lever, *l*, working over a toothed sector, serves to control the length of stroke, which may be varied from $\frac{1}{2}$ inch to 4 inches during the working of the machine. Any water carried in with the air may be blown off at the valve, *w*. A hose pipe for blowing off sand from the pattern may be attached at *h*. A guide rod, *o*, prevents any tendency of the jarring cylinder to rotate on its ram. A large machine of this type by the Tabor Company weighs altogether 45 tons, and is employed for the heaviest class of work, such as engine bed plates, parts of machine tools, etc., weighing up to 25 tons. The table measures 8 feet by 12 feet, the jarring cylinder is 36 inches in diameter, and the anvil itself, which is a solid casting, is 5 feet in diameter, and weighs $29\frac{1}{2}$ tons.

Multiple Moulding.—With the various systems of machine moulding already described, the mould is made in two parts, each of which contains an impression on one face only. But for work such as flanges, discs, washers, etc., which are flat on one side, the joint face of the upper half mould is perfectly flat, the impression being contained entirely in the lower half. Suppose

now a number of sections exactly like the lower half are rammed up, and piled one upon the other, a mould cavity is formed at

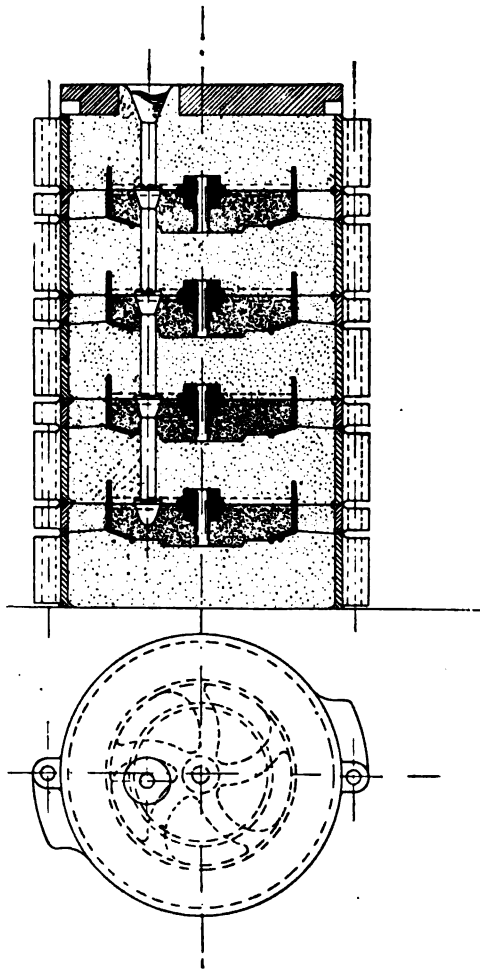

FIG. 284.—Multiple Moulding.

each joint. Thus, eight sections or boxes would contain seven moulds, producing as many castings as seven ordinary moulds, which, however, would require fourteen boxes. Hence a great saving of labour, sand, floor space, and time in pouring must result. The natural development of this idea is to form an impression on both faces of the section simultaneously, in order to render the system applicable to objects of any shape whatever. To mould these "double-faced" sections in a machine, the lower half pattern plate, fixed to the table as usual, is employed in conjunction with an upper half pattern plate, carried in a pressure frame, which comes in contact with the presser head of the machine. The box

is placed over the lower pattern plate, which is covered with facing sand. A filler frame is then added to the box, and floor sand put in, followed by a layer of facing sand on the top, the surface being struck off level. After the upper pattern

plate has been placed in position, the mould is rammed in the usual way, the sand being pressed out of the filler frame into the box. The pattern may be withdrawn by any of the methods previously described, the lifting pins or stools being of larger diameter in the lower part, so that the upper pattern plate is just lifted from the box, after which the box is lifted from the lower pattern plate. As many as ten or fifteen sections may be stacked one upon the other, exact assemblage being secured by means of guide pins and lugs on the boxes (Fig. 284). In each section after the first one, the gate or runner should be cut before removal from the machine. The whole is loaded with a heavy plate just before pouring to prevent running out. The system is extensively used for such objects as hand-wheels, pulleys, small fly-wheels, sewing, etc. machine frames, brass fittings, etc.

Wheel-moulding

Machines.—Formerly spur and bevel wheels were moulded from complete patterns, which were not only very costly to make, but

were also very liable to warp and twist or get out of shape when in use, and a large number of patterns had to be kept in stock to meet even a moderate range of requirements. The wheel-moulding machine was therefore introduced mainly with the object of saving the cost of patterns, but at the same time of producing more accurate work. The only pattern required

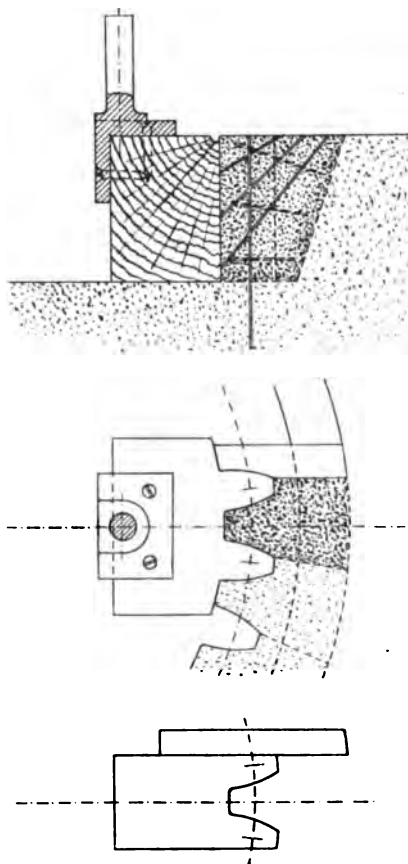

FIG. 285.—Tooth Block for Wheel-moulding Machine.

for the toothed rim is a block or segment containing two teeth, which is very accurately made in hardwood. This is attached to the radial arm of the machine, which, when adjusted to the proper radius, carries the block round exactly on the pitch circle of the wheel. The teeth are rammed up from the block one or two at a time, Fig. 285, and the block is moved round after each operation through a space equal to the pitch by means of a dividing wheel on the machine. The boss and arms of the wheel

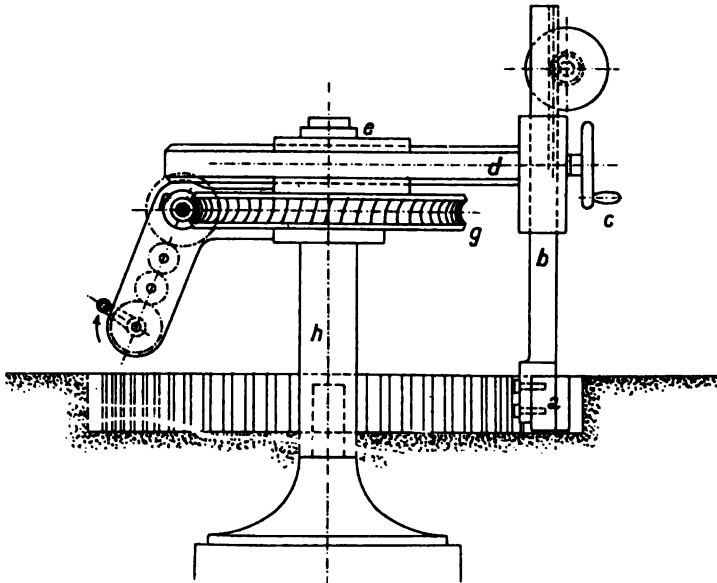

FIG. 286.—Principle of Wheel-moulding Machine.

are moulded from patterns, or struck up in the manner already described under the head of Moulding. The principle upon which the machine is constructed is illustrated in Fig. 286. The tooth-block, *a*, is fixed to the lower end of a vertical slide, *b*, which can be moved up or down by hand-wheel and rack and pinion motion at the end of the horizontal arm, *d*, of the machine. This serves to withdraw the pattern from the mould after ramming. The arm slides through vees in the rotating head, *e*, and may be adjusted to the proper radius by hand-wheel, *c*, and screw. The rotating head, in the form of a hollow casing, contains the dividing

or "indexing" gear, which consists of an accurately cut worm, *f*, and worm wheel, *g*. The worm or tangent wheel is fixed upon the top of a cylindrical pillar or centre, *h*, round which the rotating head can turn freely. The worm shaft, which has its bearings in the rotating head, is operated by hand lever through a train of change wheels used in exactly the same way as in a screw-cutting lathe. The worm wheel has usually 180 teeth, and the worm is single-threaded. If then change wheels of the same size are placed on the handle shaft and worm shaft respectively, one turn of the handle will cause the rotating head to pass through the space of one tooth of the worm wheel, *i.e.*, through $\frac{1}{180}$ of a revolution. The machine would in this case be properly set for moulding a wheel with 180 teeth. For any other number

of teeth, the ratio $\frac{\text{number of teeth in dividing wheel}}{\text{number of teeth in wheel to be moulded}}$ must

be the same as the ratio $\frac{\text{number of teeth in wheel on handle shaft}}{\text{number of teeth in wheel on worm shaft}}$

Let it be required to mould a wheel with 75 teeth, the ratio is then $\frac{180}{75} = 2\frac{2}{3}$. Placing a wheel of (say) 80 teeth on the

handle shaft, a wheel of $80 \div 2\frac{2}{3} = 99\frac{1}{3}$ teeth would be required on the worm shaft. When a fractional result is obtained in this way, it must be brought to a whole number by some convenient multiplier, in this case 3. This means that a wheel of 100 teeth may be used, provided three complete turns (= multiplier adopted) are given to the handle to move the tooth block round through a space equal to the required pitch. The handle is therefore arranged to rotate in front of a fixed dividing plate or "quartering box," which is provided with four notches, so that complete turns, or any number of quarter turns, may be given. Having decided upon the sizes of the wheels on the handle and worm shafts respectively, the intermediate or "idle" wheels on the slotted quadrant plate may be of any convenient size whatever to fill the intervening space, and do not, of course, affect the velocity ratio. The central pillar on which the rotating head turns is bolted down to a stone foundation, and therefore remains a fixture. The upper part of the machine may be removed bodily when the ramming of the teeth is complete. Two or more pillars may be fixed on separate foundations, and the same head used on any one of them in turn, so as to avoid

loss of time. Two distinct types of wheel-moulding machine have been evolved: (1) The *floor machine* just described, and (2) the *table machine*. The first cannot be used for small wheels on account of the space occupied by the central pillar, but may easily be made to deal with diameters up to 15 feet. An example of a machine of this type by Messrs. Duncan Stewart

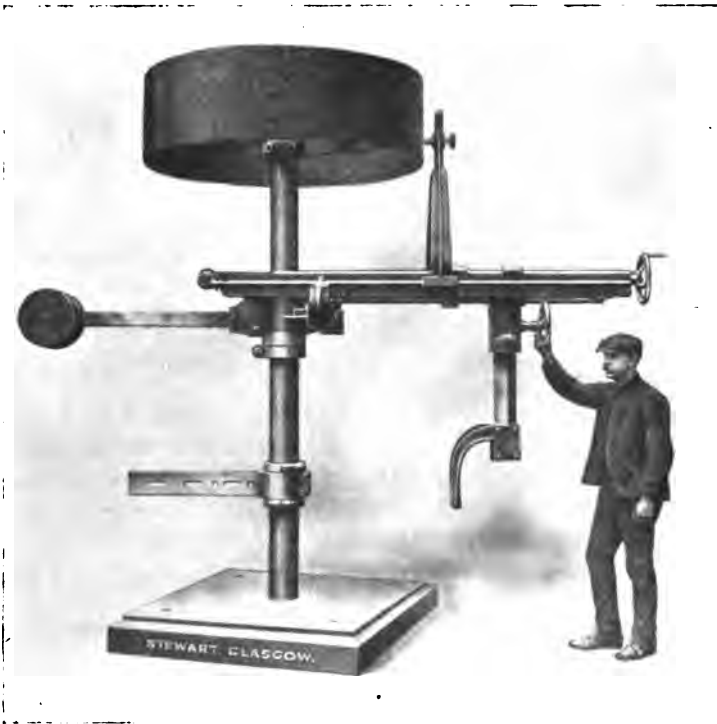

FIG. 287.—Wheel-moulding Machine. Floor type.

& Co., Ltd., of Glasgow, is shown in Fig. 287. A new feature is the employment of a dividing drum, instead of the usual change gear, for the indexing motion. The drum, which is 5 feet in diameter and 18 inches wide, is clamped upon the top of the central pillar. It is provided with 50 rows of holes, accurately drilled in a special dividing machine, the first row numbering 51, and the last row 100. The jib carries a bridge piece, which has a vertical slot to enable the dividing pin to be fixed in any

position throughout the entire width of the drum. The dividing pin is tapered, and held in the hole in the drum by a spring, so



FIG. 288.—Wheel-moulding Machine. Table type.

that when in position there is no slack. On withdrawing the pin to rotate the jib, a quarter turn locks it in the "out" position. The number of teeth in the tooth block, and the number of holes in any row on the drum taken at one time,

may be varied to give the number of teeth required in the wheel to be moulded. Thus, 105 teeth may be obtained by having three teeth in the moulding block and taking two holes at a time on the row of 70 holes on the drum. In the *table machine*, the overhanging arm or jib carrying the segment block when once fixed at the required radius, remains stationary, the "pitching"

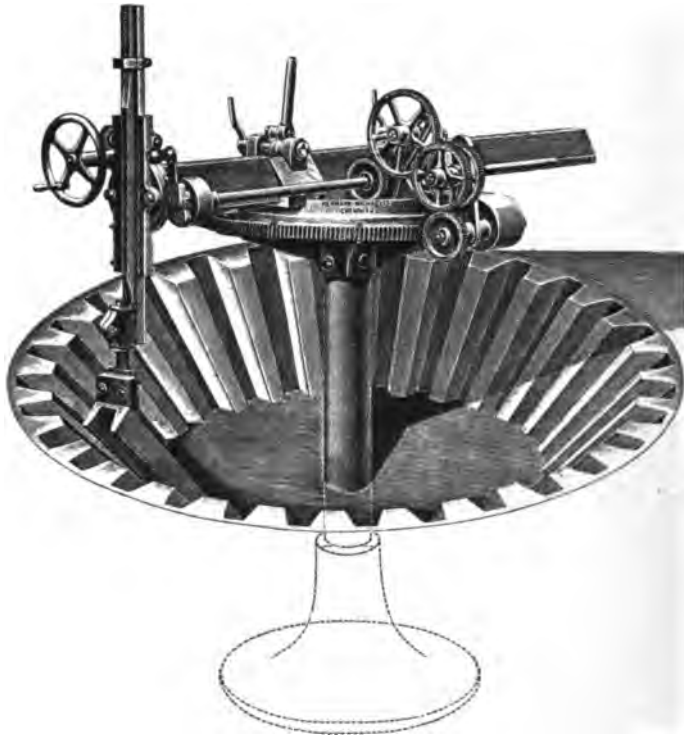

FIG. 289.—Moulding Bevel Wheel by Machine.

movement being given to a rotating table on which the moulding box is placed. This type of machine is specially suitable for small-sized wheels up to about 30 inches in diameter. The general arrangement will be gathered from Fig. 288, which represents a machine made by the London Emery Works Company, Tottenham, London. The operation of moulding the teeth of a bevel wheel is well shown in Fig. 289. Either type of machine may also be adopted for *moulding helical and worm*

gears, in which case the pattern block must be withdrawn after ramming by imparting to it a helical movement. For this purpose a small horizontal slide, operated by rack and pinion, is provided at the lower end of the carrier, to which for spur gear-



FIG. 290.—Moulding Helical Gear on the Bonvillian System.

ing the pattern block is directly attached. In connection with the Bonvillian system already described, Messrs. Greenwood and Batley, Ltd., have introduced a very simple and effective method of moulding the helical wheels used for operating the valve gear of gas engines. The wheels are moulded in greensand, both

mould and core being rammed entirely in the machine. The pattern is withdrawn by means of a template fixed on the table of the machine, which ensures accuracy both in form of teeth and in spiral pitch. The mechanical pattern plates, the pattern plates for forming greensand cores, the complete moulds, and the gears themselves are shown in Fig. 290.

Core Machines.—Probably the limit to the application of machine moulding arises in connection with core-making.

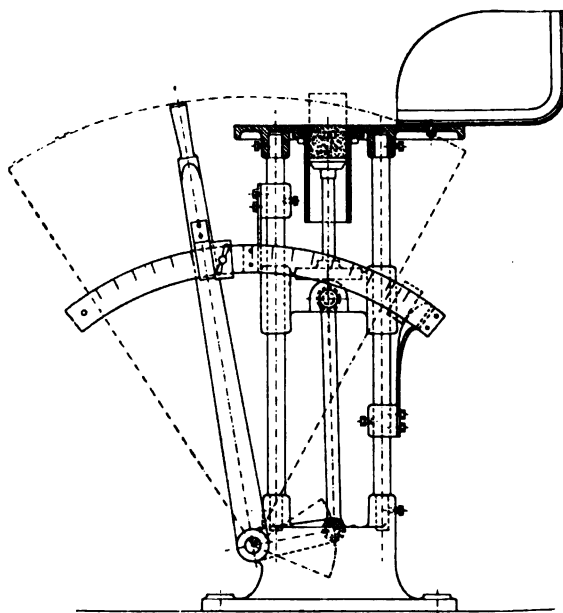

FIG. 291.—Core-making Machine. Plunger Type.

This, of course, does not apply to castings which can be produced without cores, or to those in which the cores are of plain cylindrical or prismatic form. It is doubtful, however, if cores of anything more than comparatively simple shape can yet be produced satisfactorily by machine. Parallel cores of round or square section may be made by machine in two different ways. The first or plunger type of machine, Fig. 291, is little more than a handy means of rapidly adjusting the diameter and length of the core-box, in which core sand is rammed by hand as usual, the core being finally ejected by the motion of a plunger

or piston. Any stock size of core-box can be fixed in an opening in the cast iron table, and the corresponding size of piston attached to the vertical rod. The piston is then placed in the proper position by moving the lever to give the required length of core as read off on the graduated arc. After clamping the lever in position, core sand stored at the rear of the table is rammed into the box, a core iron, if necessary, being inserted, and the core vented as usual. On releasing and pulling forward the hand lever, the completed core is forced out at the top. In

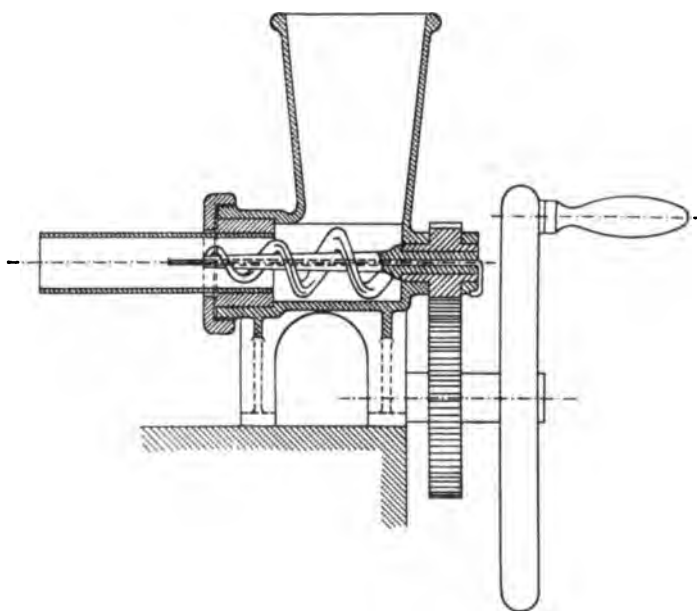

FIG. 292.—Core-making Machine. Sausage-machine Type.

the second or "sausage machine" type of core machine, Fig. 292, the sand is filled into a hopper, and is forced through a nozzle or die of the required size by means of a horizontal screw, which may be driven by hand or power. The core is produced in a continuous length, with a small vent hole down the centre, and is afterwards cut to the dimension required. A special mixture of sand with linseed oil or other "binder" must be used, and as will be evident, core irons cannot be inserted. Both types of machine are limited to making straight cores, although the form of section admits of some variation.

Die Casting.—In this process, molten metal is forced into steel moulds or dies under high pressure, and coming in contact with the relatively cool surface of the die, it chills quickly and forms a hard fine-grain surface on the casting. Pieces of very irregular shape may be produced in this way finished so smoothly and accurately that machining is unnecessary, the castings as they come from the mould being ready to go straight into place.



FIG. 293.—Group of Parts produced in Die-casting Machine.

The process is limited to parts weighing not more than 2 or 3 lbs., and is confined to the use of the softer metals, such as aluminium, zinc, tin, lead, and antimony and their alloys. It is extensively employed for light castings which have to be produced in large quantities, such, for instance, as the parts of telephones, typewriters, sewing machines, counters, gas and water meters, medical instruments, magnetos, carburetters, gear cases, lubricators, pumps, valves, safety razors, etc. The method has proved to be particularly well adapted to the production of



FIG. 294.—Die-casting Machine.

bearings for motor car engines and light machinery, as shown in Fig. 293, which represents a group of such castings by the Franklin Manufacturing Company, of New York, one of the first

firms to engage in this branch of work. A simple form of die-casting machine by Messrs. C. Neat & Co., of London, is shown complete in Fig. 294. The metal is placed in a gas-heated container, the lower portion of which forms a pump barrel, Fig. 295. The molten metal is forced upwards through the

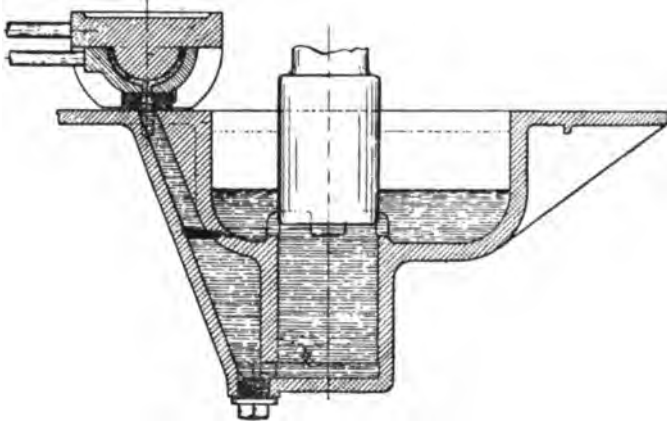

FIG. 295.—Gas-heated Container for Die-casting Machine.

inclined passage into the steel dies at considerable pressure, thus ensuring great density in the casting. The dies shown in the section are those for a half bearing, and are held down by the clamping screw seen in the general view. Motion is given to the pump plunger by rack and pinion operated by the large hand-wheel. The machine shown can turn out castings up to 3 lbs. weight at the rate of 100 to 300 per day.

PART III.

PREPARATORY PROCESSES—*continued.*

CHAPTER XXX.

SECTION B.—PROCESSES DEPENDING UPON THE PROPERTIES OF MALLEABILITY AND DUCTILITY.

THE operations of *forging, pressing, stamping, drawing, rolling, etc.*, involve a change of shape in a solid body brought about by taking advantage of the properties of ductility, malleability, and plasticity, which are possessed to a greater or less extent by most metals. *Ductility* is that property which enables a body to be drawn out, or extended in the direction of its length, *i.e.*, to be converted into wire. Hence the most ductile metal is that from which the finest wire may be produced, *viz.*, gold (see page 12). Ductility depends mainly upon tenacity, and to a less extent upon hardness. As a rule, fairly soft metals of high tensile strength are the most ductile, and hence iron is more ductile than copper. *Malleability* is the property which permits of a body being beaten out, or extended in all directions, *i.e.*, being converted into thin sheets, foil, or leaf. The most malleable metal is therefore that from which the thinnest leaf may be produced, and gold again heads the list (see page 12). The effect of hardness upon malleability is much greater than upon ductility, which is the reason why copper is much more malleable than iron, although less ductile. *Plasticity*, or "solid flow," is the property by virtue of which a solid body may be shaped into any desired form by pressure. This has no relation whatever to the property of fluidity of a metal when molten, which, as already described, is utilised in making castings. Plasticity may be defined as the absence of elasticity. Wet clay and lead, which retain any impression made on them, and show little power of recovery after the pressure is withdrawn, are good examples of plastic substances. The application of

external pressure causes the particles of the substance operated on to roll freely over each other, and the more readily the particles submit to this movement without losing their natural

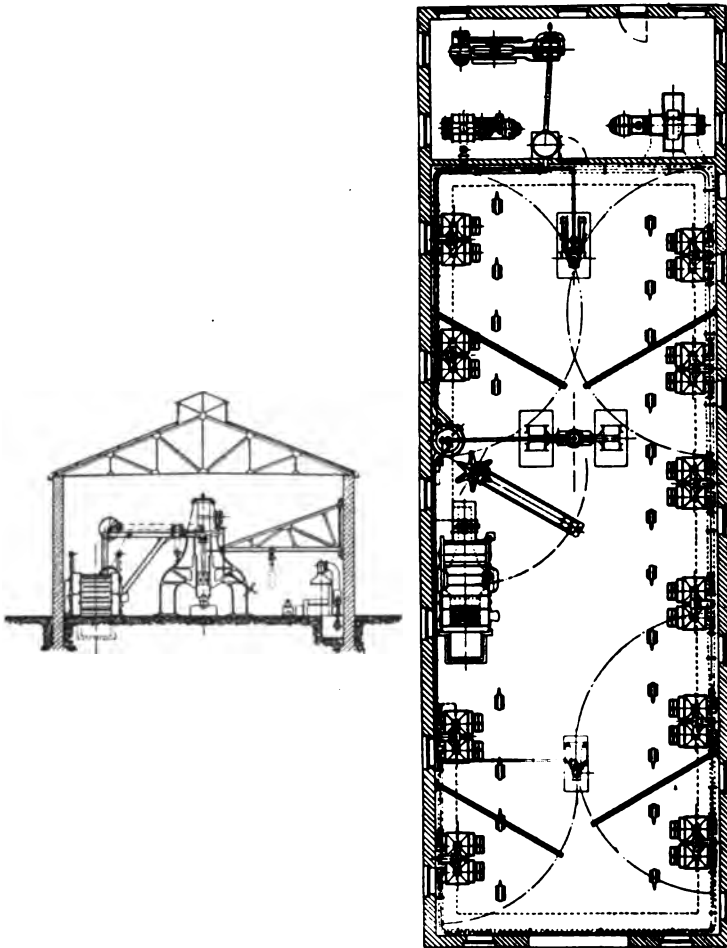

FIG. 296.—General Arrangement of Smith's Shop.

cohesion, the greater the plasticity of the given substance is said to be. The opposite property is that of brittleness.

Smith Work and the Production of Forgings.—Certain of the metals, as, for instance, gold, possess a remarkable degree of

malleability at ordinary temperatures; others again, such as wrought iron or steel, must be heated to a high temperature to render them easily workable, and a few others, as in the case of zinc, are malleable only within very narrow limits of a certain fixed temperature. It will be found that in almost all cases of any practical importance the material is operated upon in a heated condition. Wrought iron and mild steel afford by far the most frequent examples of this mode of treatment, which may be divided into two distinct branches, according to the method of heating employed: (1) **Smithing**, which is understood to comprise small pieces only, such as can be heated in an open "fire" or "hearth," whereas the operation of (2) **Forging** refers to the production of those parts which must be heated in a closed furnace. The shop in which work of the first class is carried on is known as the *smithy*, or *smith's shop*, and the various operations are effected mainly by *hand labour*, or with the aid of small *steam or power-hammers*. That portion of an iron or steel works devoted to the production of forgings and similar parts is termed the *forge*, and the work is mainly performed by means of *heavy hammers, forging machines and presses*, and other mechanical appliances. A convenient arrangement of the *smithy and forge* for an engineer's shop is shown in Fig. 296, and the various appliances will now be described in detail. The smithy is usually a rectangular one-storied building, with the hearths or fires, of the pattern shown in Fig. 298, each with its anvil and equipment of tools, arranged in suitable positions round the outer walls. All are served by one blast main running round the building, blast being supplied by means of a fan or blower. The engine room, containing the blowing and (if necessary) air compressing machinery, is situated at the end of the main building. One or more steam or power hammers occupy a central position, and are reached by light overhead jib cranes from the adjacent fires. The largest hammer, of the type shown in Fig. 399, is placed near the centre of the shop, with the heating furnace (see Fig. 303) adjoining. At each end is a smaller hammer of the Rigby type, Fig. 336, within reach of any one of the adjacent fires by means of the two jib cranes, as shown. The fixed *hearth or fire* is of two distinct types, being either built of brick, or constructed throughout of iron. There is also a portable forge combined with bellows, which is used principally

for rivet heating and other outdoor work. In all cases the work comes into direct contact with the fuel, and the condition of the fire is therefore one of the most important factors in all forging operations. The best fuel is probably coke "breeze,"

or gas coke crushed to a suitable size, but soft bituminous coal is very often used. It should be free from sulphur, and when placed on the fire should "cake" without falling to pieces, producing coke with but little clinker. Two methods of arranging the fuel are in common use, termed respectively (1) the stock fire, and (2) the open fire. The former is generally adopted with a *brick-built hearth*, an example of which, provided with two fires, is shown in Fig. 297. The brickwork, bound together by an angle iron framè at the top, encloses at each side a hollow space or depression through the end of which projects the blast nozzle or "tuyere." The blast may be regulated, or cut off altogether, by means of a plate or valve sliding between two flanges in the pipe. Above the two fires is a sheet iron "hood" leading to the

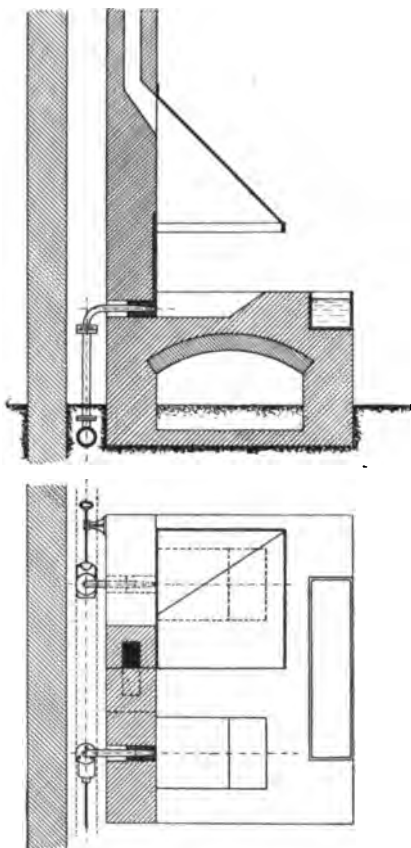

FIG. 297.—Brick-built Smith's Hearth.

chimney. In front of the fire is a "slake trough," usually of cast iron, and a coal or coke bunker is placed in a convenient position, or may be arranged in the hollow space beneath the hearth. To keep in the heat of the fire the smith makes use of the coal as a non-conducting material, to which end it is broken up small and thoroughly damped with water from the slake trough.

This damp or "green" coal prevents the fire from spreading too rapidly, and produces better coke. A stock fire is intended to last for several hours, and is especially useful in dealing with

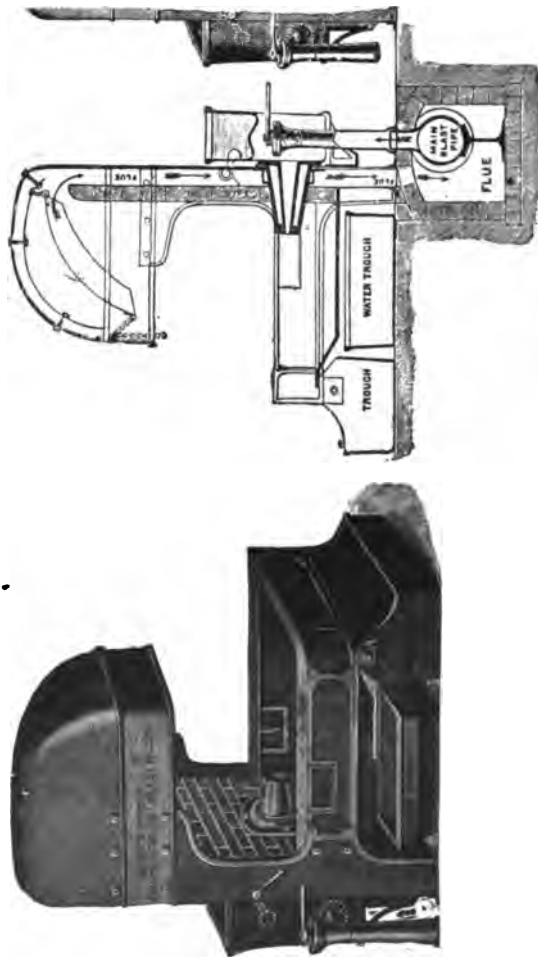

FIG. 298.—Smith's Hearth of Cast Iron.

larger pieces, when a heat may have to be kept up for some time. With this method of working, the tuyere need not be water-cooled, and it is claimed that some trouble on that score is avoided. Before commencing work, the fire is made up round a block of the size desired, which is placed over the tuyere, and

upon which fresh coal is closely built into the form of a mound or "stock." The block is then withdrawn, and the fire lighted in the opening left. Here the work is heated, being carefully covered with freshly-coked fuel from time to time as the fire burns away.

The brick-built hearth has been to a considerable extent displaced by the cast iron type, mainly on account of the facility with which the latter may be moved from one part of the smithy to another, should alterations become necessary. A *cast iron hearth* made by Messrs. Alldays and Onions, Ltd., of Birmingham, is shown in Fig. 298. The hearth is of the so-called "chimneyless" variety, and is fitted with a raised hood or bonnet, opening into a rectangular passage formed in the firebrick lining of the back. This passage leads down into an underground flue which communicates with a tall stack or chimney for creating the necessary draught. Through the back projects the blast nozzle or tuyere, often called the "tue iron," which is made in the form of a water-jacketted hollow cone of wrought iron, kept cool by the circulation of water contained in a cast iron tank or "water bosh" to which it is attached. The end of the nozzle is thus prevented from burning away, and the tendency of clinker to cake upon it is avoided. The blast enters through the "blast standard," which is a vertical stand-pipe connected to the blast main, and is provided with a cock by means of which the pressure may be regulated. The cock is connected to the tuyere by an elbow pipe passing through the water in the tank. The front of the hearth is carried upon a large trough to contain slack or coal. The water trough is at the side, and is arranged with a sloping front for easy access. With this form of hearth, an "open" fire is used, which is made up in the hollow space with coke left from the last fire, covered over with green coal. As the fire burns away, coke from the top and sides is thrust into the centre, and its place taken by more green coal taken from the supply maintained on the front plate. The "*down-draught*" hearth, as made by the Buffalo Forge Company, shown in Fig. 299, is constructed of cast iron, and is operated with two fans, one for producing the blast, as usual, and another for creating the necessary draught for taking away the smoke and fumes. The freedom from smoke and the better ventilation of the building, together with the clear space overhead

which results from the adoption of this type of hearth, are great advantages in its favour. Instead of the water-cooled tuyere at the back as formerly used, the blast enters from below through an adjustable nozzle or "ball tuyere" in the centre, which ensures a much better distribution of the blast.

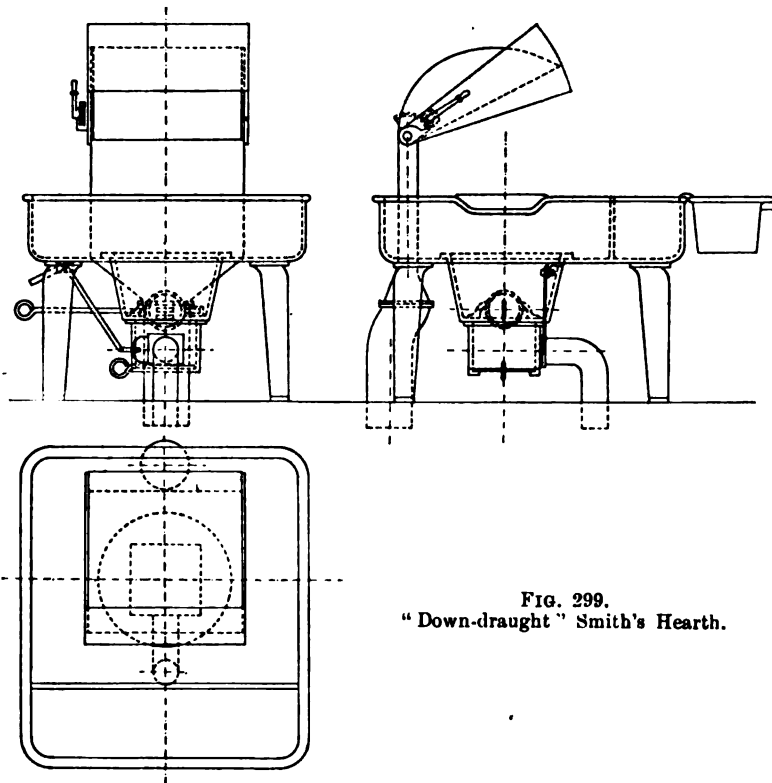

FIG. 299.
"Down-draught" Smith's Hearth.

Any ashes which fall through the nozzle from the fire may be blown out by opening a valve in the box immediately below.

The *blast*, or air under pressure for urging the fire, is supplied in the case of small *portable fires* by means of a bellows, Fig. 300 but either a fan or a blower driven by power is always employed for the smithy. A fan is best adapted for moving a large volume of air at a small pressure, and to be effective must be run at a high speed, or about 3,000 revolutions per minute,

which frequently necessitates a countershaft or other gearing. It is true that several important improvements have recently been introduced, and the fan is still retained in many works. A well-known form for the purpose is shown in Fig. 219. On the whole, however, a Roots' blower would seem to be preferable, and is probably both more efficient and economical when the air has to be delivered at any appreciable pressure. An example,

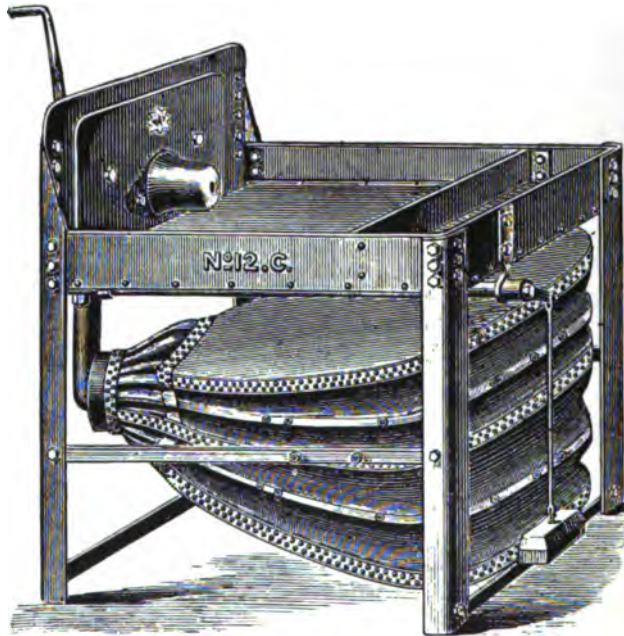

FIG. 300.—Portable Forge.

made by Messrs. Thwaites Bros., Ltd., of Bradford, is shown in Fig. 301. Two properly shaped "rollers" or impellers, (see Fig. 220) fixed on shafts which are geared together by equal spur wheels, revolve in opposite directions inside a casing in such a manner as to draw in air at the inlet on the top, and force it out under pressure into the blast main below, the speed as a rule not exceeding 300 revolutions per minute. In some cases where several fires are supplied from the same blower, a reservoir, fitted with an escape valve, is employed for the purpose of maintaining a constant pressure in the blast main. It is very

important that proper means for regulating the blast should be applied to each hearth. A common tendency is to blow the fire too hard, when the oxygen contained in the surplus

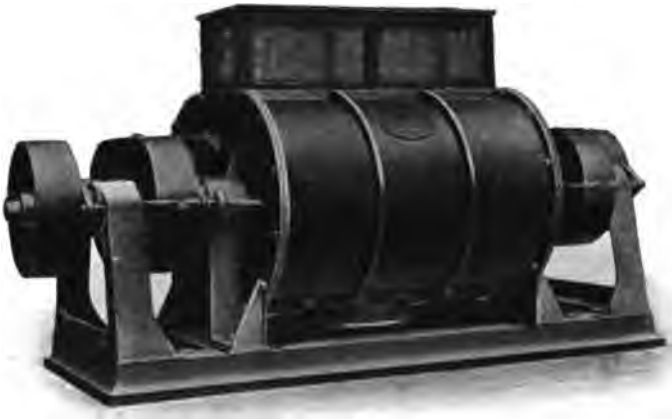

FIG. 301.—Roots' Blower, for blowing Smiths' Fires.

air causes the iron to burn, forming scale. This action cannot perhaps be entirely obviated, but especially for welding, care should be taken to avoid an oxidising fire, as it is termed.

Heating Furnace.—In the forge, for large work executed

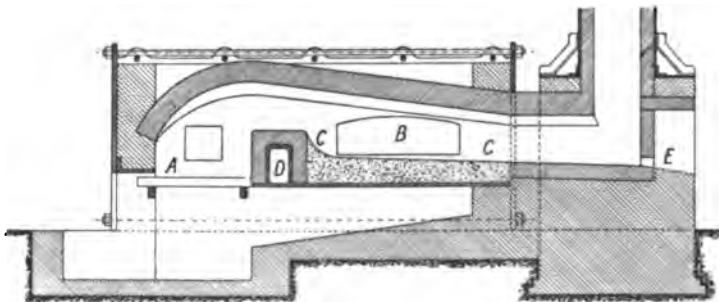

FIG. 302.—Heating Furnace for Forge.

under the steam hammer, a heating furnace of the reverberatory type is employed. As will be seen from Fig. 302, the furnace is fired with coal, burnt upon the grate, A, and does not therefore

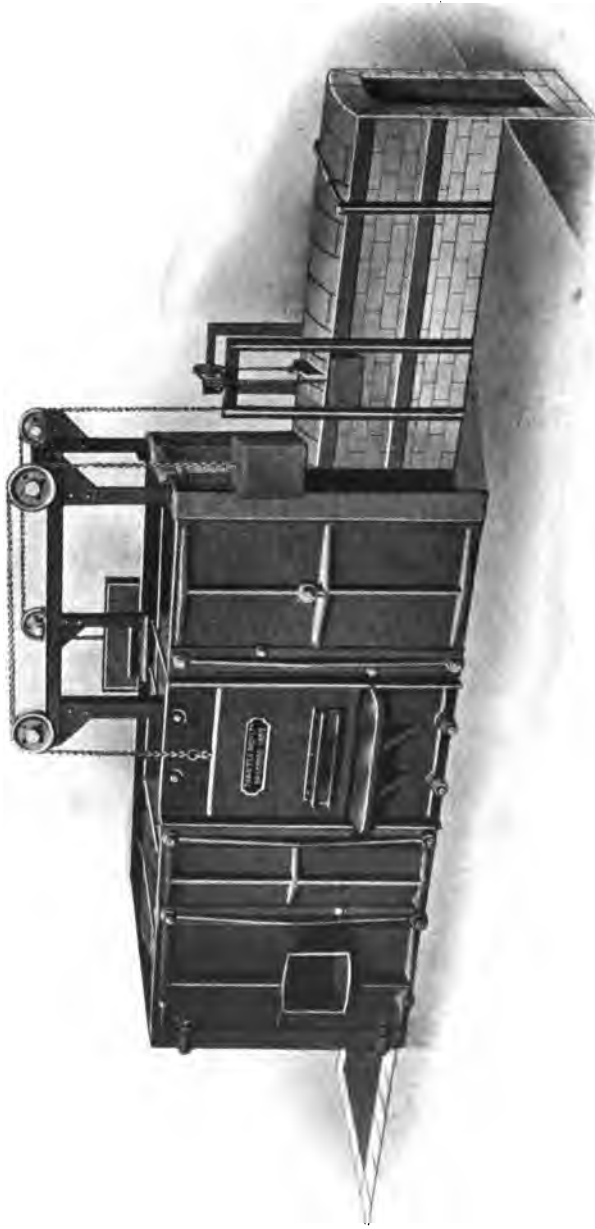

FIG. 303.—Heating Furnace for Forge.

come in direct contact with the work to be heated, which is introduced through door, B, and placed upon the bed, C, formed of sand. An air-cooled cast iron bridge, D, protected with firebrick, causes the flame to impinge upon the hearth, and any scale produced by the oxidising action of the flame unites with the sand to form a slag which is run off at the tapping hole, E. The furnace is constructed of firebrick, held together by iron plates or buckstaves and tie rods, as shown in Fig. 303, which

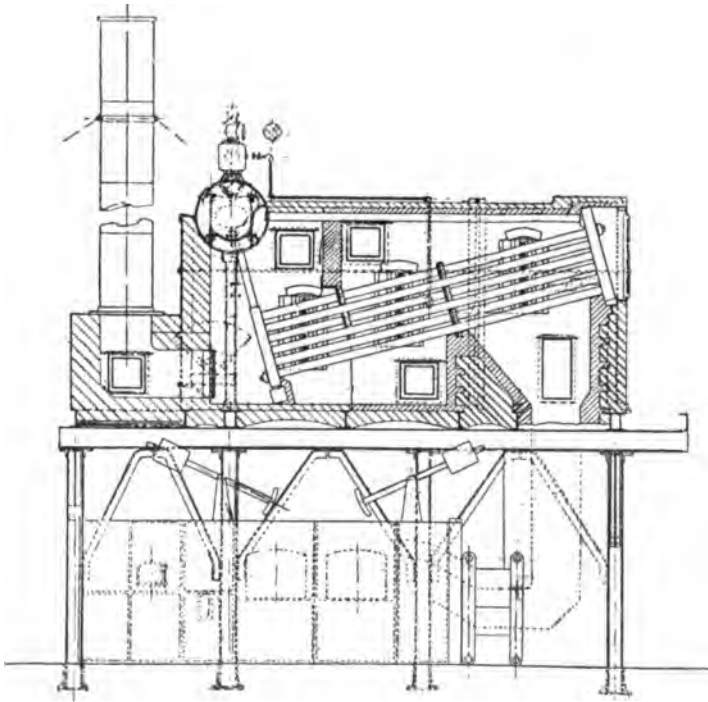

FIG. 304.—Scrap-heating Furnace with Water-tube Boiler.

is an external view of a heating furnace made by Messrs. Thwaites Bros., Ltd., of Bradford. The fire-door is seen on the left, the counterbalanced working door in the centre, and the flue leading to the chimney on the right. The products of combustion escaping at a high temperature, are frequently utilised for steam-raising purposes on their way to the chimney, otherwise the heat usefully employed in heating the metal is not likely to

exceed 10 per cent. of that produced by the combustion of the fuel. Fig. 304 shows a scrap-heating furnace by Messrs. Alldays and Onions, Ltd., of Birmingham, combined with Babcock and Wilcox boiler fired with the waste gases, for supplying steam to steam hammers, etc. Gas-heated furnaces, working in conjunction with Siemens regenerators, are capable of effecting considerable economy, and oil-fired furnaces have recently been used with great success.

Tools used in Forging.—The principal tool used by the smith is the *hammer*, which is employed in conjunction with the *anvil*, on which the work is laid. The effect of the blow is not due entirely to the weight of the hammer, but depends very largely on the velocity with which the hammer strikes the work, and is proportional to the kinetic energy, or energy of motion of the hammer,

$$\frac{Wv^2}{2g} = \frac{Wv^2}{64.4} \text{ foot-pounds.}$$

where W = weight of the hammer in lbs., V = velocity in feet per second on striking the blow, and $g = 32.2$ feet per second, the acceleration due to gravity. The whole of this energy can only be utilised in producing a change of shape if the work has no appreciable elasticity, and is incapable of motion on receiving the blow. Hence the support or anvil should be of ample weight, or for hand work, say from 30 or 40 times that of the heaviest hammer, and should be as firmly fixed as possible.

The *hammers* employed for smithwork are of two kinds:—(1) the *hand hammer* used by the smith himself, and (2) the *sledge hammer*, used by his assistant or *striker*. Both kinds should be made of cast steel throughout, with the end faces carefully hardened and tempered, the portion round the eye being left soft. The hand hammer should weigh, for ordinary work, from 2 to 3 lbs., and the shaft should be about 14 inches long. The best and most usual form is that known as the ball pene, Fig. 305 (a), with the large end slightly convex, and the small end or pene, hemispherical. The latter is useful for upsetting scarfing, rivetting, etc. Other varieties which are frequently in request, are the straight pene, Fig. 305 (b), and the cross pene, Fig. 305 (c), in which the pene is formed like a blunt wedge, and is rather effective when drawing down. The blacksmith's or

rivetting hammer, Fig. 305 (d), is, in addition to its own special use, preferred by many smiths for ordinary work. The common form of the sledge hammer is double-faced, Fig. 305 (e), but straight pene and cross pene sledges, Figs. 305 (f), and 305 (g), are also employed. For ordinary work, the most suitable weight is from 10 to 12 lbs., and for heavy work, from 16 to 20 lbs., the shaft being from 3 feet to 3 feet 6 inches long. The sledge hammer may be raised up to the shoulder for moderate blows, or

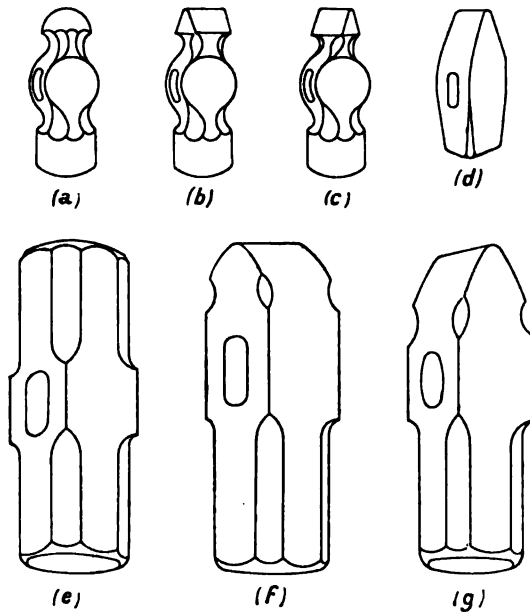

FIG. 305.—Forms of Smith's Hammer.

it may be swung when used on heavy work. The swing is made entirely on the right side of the body, with the left arm square across, so that the left hand, which grasps the shaft as near the end as possible, becomes a sort of fulcrum. The right hand when lifting, approaches to within 6 or 8 inches of the hammer head, and is allowed to slide down the shaft towards the end as the work is approached, thus delivering the full force of the blow. When at work, blows are given alternately by the smith and his striker, the former indicating by means of his hand hammer, the exact spot upon which the sledge shall fall.

The smith finally allows his hammer to ring on the anvil as a sign that the work is complete.

The *anvil* is generally made of wrought iron or mild steel with a "face" of cast steel welded on and hardened. The usual shape, shown in Fig. 306 (a), for use in an engineering shop, is known as the English anvil, and for average work the weight should be about 3 cwts. The horn or beak is soft like the body, and square

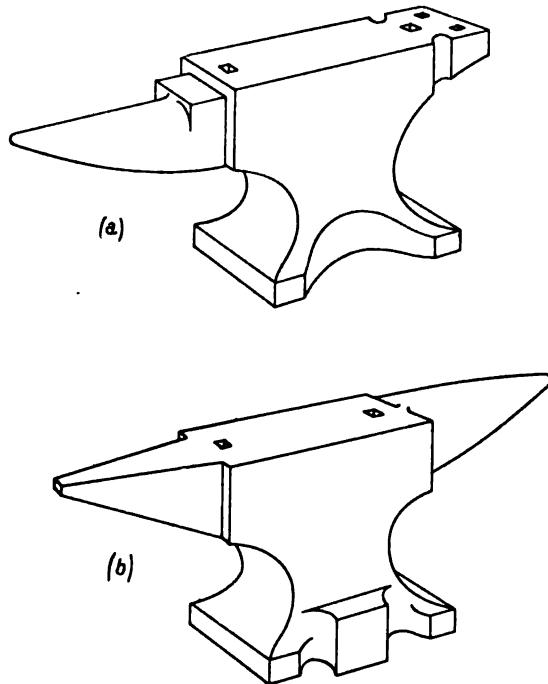

FIG. 306.—Smith's Anvil.

holes are provided at the ends of the face to take the stems of bottom tools to be described later. To bring the face to the proper height, viz., 2 feet above the ground, the anvil is placed upon a *block* or *stand*, which may be either of wood or of cast iron, Fig. 307. When in position, the beak should be on the workman's left. The so-called "French" anvil, Fig. 306 (b), largely used on the Continent, has a horn at each end, one of round section and the other trapezoidal. The first serves for ring

making, or for bending to a radius, and the latter is very convenient for square corners, Fig. 306 (b). A dowel pin, driven into the wooden block, or cast in the iron stand, as the case may be, enters a hole in the bottom of the anvil, and serves to prevent any lateral movement.

Hand tools are required for those operations such as cutting, punching, etc., for which the hammer is not directly available, or for finishing work after it has been brought roughly to shape by



FIG. 307.—Anvil on Cast Iron Block.

the hammer. Two of each kind, forming a pair, and known as *top and bottom tools* respectively, are generally used together, the former being held by the smith, and the latter having a stem which is placed in the square hole in the face of the anvil. These tools are divided into several groups, viz.:—(1) chisels, (2) fullers, (3) flatters, (4) swages, and (5) punches, and of these, excepting the first, several different shapes, with four or five sizes of each, are required for everyday use. *Cold and hot Chisels* are employed for cutting off cold stock, and for hot metal respectively. These tools may be made with an eye and shafted like a hammer, or the body may be left cylindrical and a rod of hazel

or of round iron bent to form a handle as in Figs. 309 and 310. The latter being to some extent loose, relieves the hand from jarring and shock, but the shaft enables the tool to be placed and held more accurately in position, and is now commonly preferred, except for rough work. The cold chisel, Fig. 308 (a), is forged thick in the body, and the cutting edge is hardened and tempered

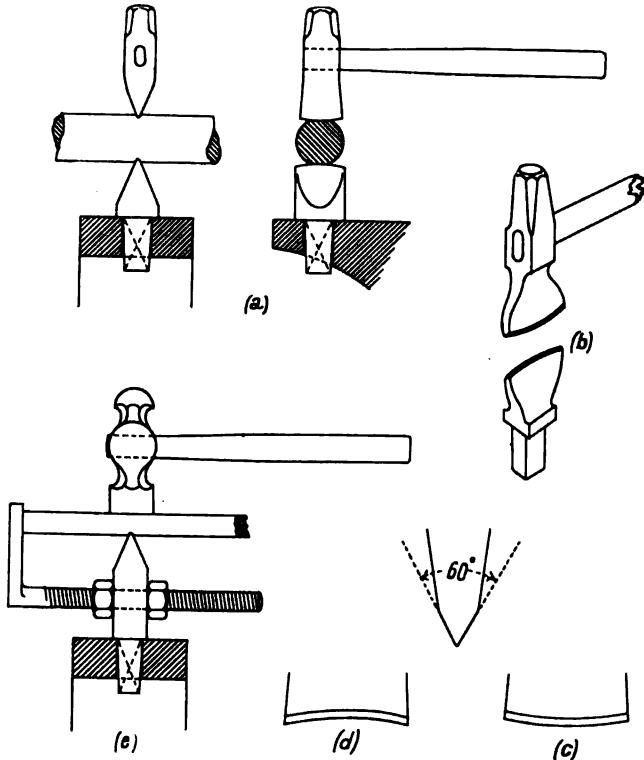

FIG. 308.—Cold and Hot Chisels used by Smiths.

to purple, the body remaining soft. The hot chisel, Fig. 308 (b), is forged thinner and wider in the blade, and having to cut hot metal which would soon draw the temper, need not be hardened. Chisels should be ground with the cutting edge slightly convex, Fig. 308 (c), and never hollow, Fig. 308 (d), or even straight, as the corners are then sure to be broken off. The proper angle between the facets is 60° for the cold chisel, and 30° for the hot chisel.

Hence each should be retained exclusively for its own special purpose, as the cold chisel, if used on hot work will have its temper drawn, and the edge of the hot chisel will be "turned" and "knocked up" if used for cutting cold metal. The above remarks apply equally well to the corresponding bottom cutters, or *hardies*, as they are sometimes termed. Fig. 308 (e), shows a hardie with adjustable cutting-off gauge, which is an extremely useful appliance when a number of pieces of the same length are required. Closely allied to chisels are the *gouges*, Fig. 309 (a), which are also made as top and bottom tools, and are useful for dealing with circular work. *Fullers* or "necking" tools, may be described as very blunt chisels with well rounded edges, the size of the tool being denoted by the size of the groove which it is capable of making, what is known as a $\frac{3}{8}$ -inch fuller having a semi-circular edge of $\frac{3}{8}$ inch diameter. Fullers, like chisels, are made in pairs, as top and bottom tools, Fig. 309 (b), and they are used for

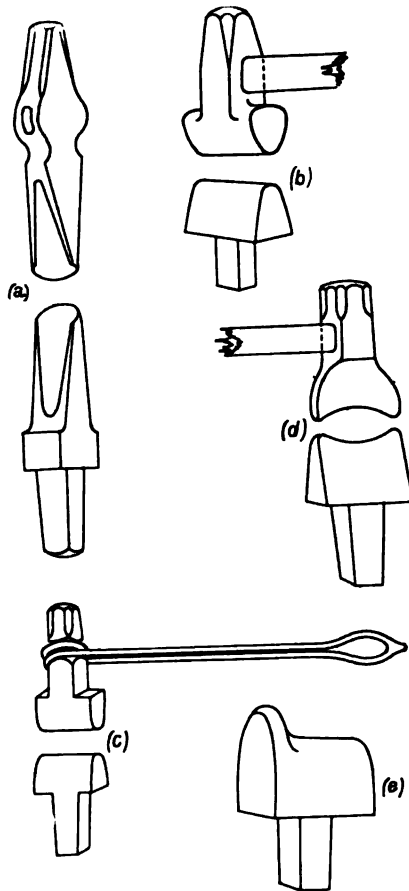

FIG. 309.—Smith's Tools. Gouges and Fullers.

indenting or "setting down" work when drawing out, for finishing rounded corners, and by boilermakers instead of chisels for caulking. *Shouldering fullers*, Fig. 309 (d), are hollowed out to a radius and rounded off in the same way as ordinary fullers, and are used for cylindrical work.

Bottom fullers are sometimes made with a flange or stop, Fig. 309 (e), which prevents the work leaving the fuller when turning over. *Flatters*, Fig. 310 (a), are used for "flattening" and finishing plane surfaces, and have perfectly flat faces about 3 inches square, or it may be circular, or rectangular. The *set-hammer* is a similar but smaller tool, used for forming shoulders and getting into corners. Flatters and set-hammers are sometimes required with square edges, but

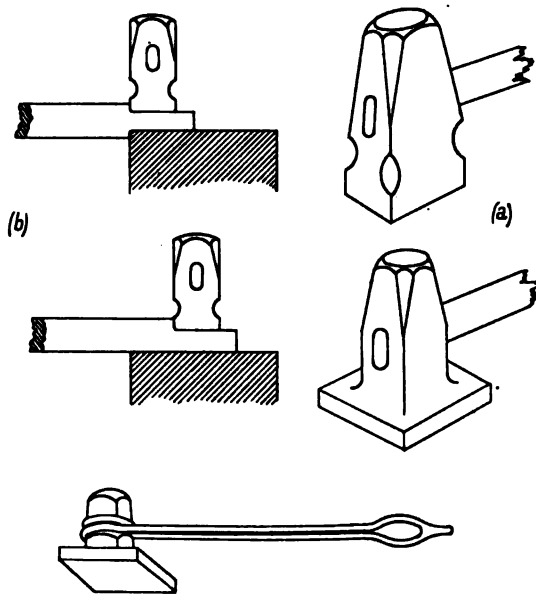

FIG. 310.—Smith's Tools. Flatters.

whenever the work will permit of it, the corners of these tools should be well rounded, to avoid any tendency to start a fracture in the work. No bottom tools are required, the face of the anvil doing duty in this respect, Fig. 310 (b). *Swages*, Fig. 311 (a), constitute an important class of top and bottom tools used for finishing work of cylindrical, square, or hexagonal form, Fig. 311 (c), or they may partake of the nature of dies, Fig. 311 (f), in which collars or other projections may be completed. The top and bottom tools are sometimes united as shown in Fig. 311 (d), or by means of a bow of flat spring steel,

Fig. 311 (e). These forms are especially suitable for small work, as the aid of a striker may then be dispensed with, the smith working *single-handed*, as it is termed. For work which can be finished under the hammer, the bottom swage may be used alone, the work being

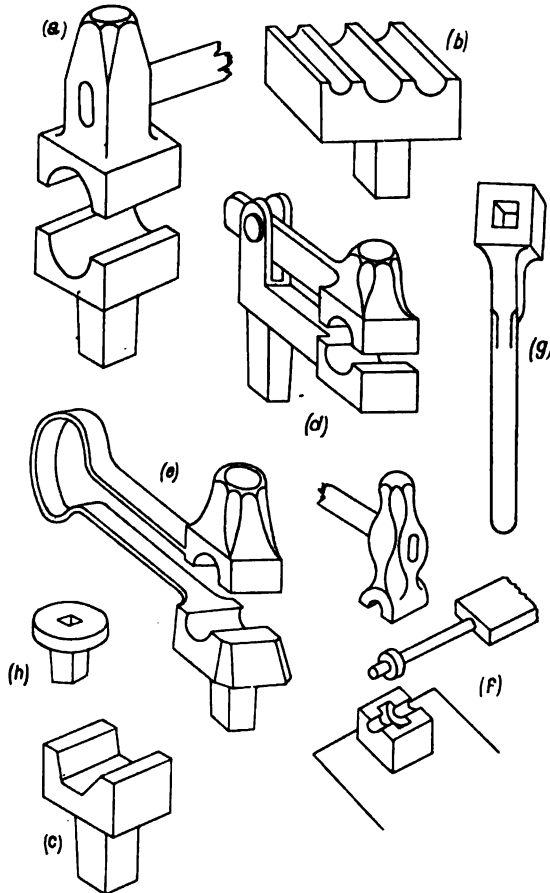

FIG. 311.—Smith's Tools. Swages.

rotated during the operation. The *Swage Block*, which is usually of cast iron, 4 or 5 inches thick, is mounted on a stand of cast iron, Fig. 312 (a), or of wrought iron, Fig. 312 (b), and embodies a wide range of shapes and sizes for this purpose. Any edge may be placed uppermost, and the holes are used for knock-

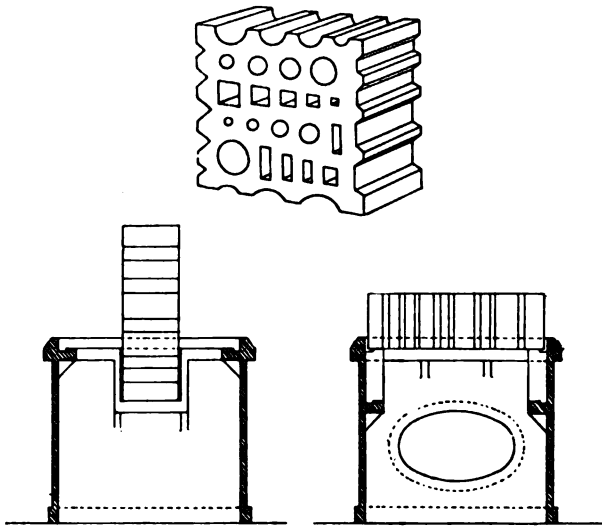

FIG. 312 (a).—Smith's Tools. Swage Block and Stand.



FIG. 312 (b).—Swage Block and Stand.

ing up a head on the end of a bar which, after being heated, is just struck a few blows on the anvil to form an enlargement or shoulder. The *Heading Tool*, Fig. 311 (g), is used for the same purpose, and is held in one hand, being placed over the hole in the anvil to allow the rod to pass through.

After forming the head, it is turned over, and the bar knocked out from the opposite side. A heading tool with square shank to fit in the hole in the anvil is shown in Fig. 311 (h). Another form, combining several sizes in one tool, will be seen in Fig. 313 (h). *Punches.*—For small work, the hand punch, Fig. 313 (a), is generally employed, but when working with a striker, punches of circular, square, elliptical, or cotter section, Fig. 313 (b) and (c), and fitted with handles of the same pattern as for the tools previously mentioned, are used over the hole in the end of the anvil. Being intended for use on hot

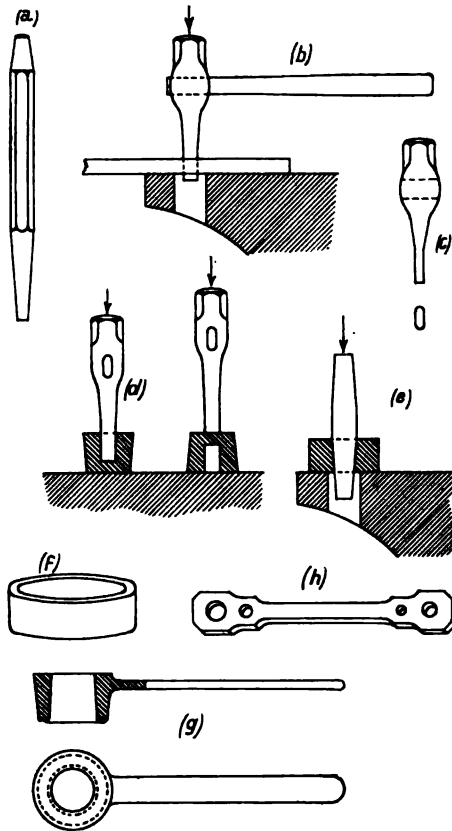

FIG. 313.—Smith's Tools. Punches and Drifts.

metal, they should possess an ample amount of taper, and the cutting end should be perfectly flat and square across. The proper method of punching a hole is to lay the work flat upon the anvil, and drive the punch about half way through from one side. The work is then turned over, and the "punching" knocked out from the other side, to avoid striking the anvil, and to give a

clean cut hole on both sides, as shown in Fig. 313 (d). *Drifts* are conical steel pins, slightly tapered, and of various forms of

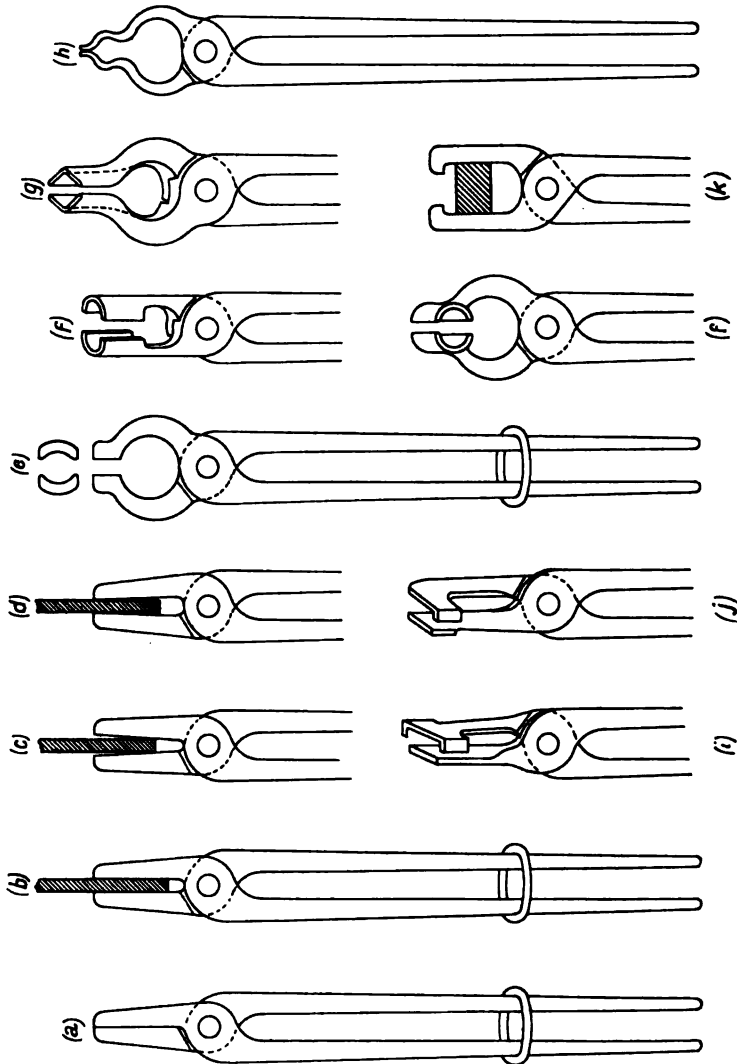

FIG. 314.—Smith's Tongs.

section, which are used for opening out a small hole made by the punch to the full size required, while maintaining the proper thickness round the hole, Fig. 313 (e). *Ferrules*, without and

with handles, Fig. 313, (*f*) and (*g*), are employed for cutting out and stamping circular bosses or similar parts, and are, of course, required in a number of different sizes. For holding work, a large assortment of *Tongs* of various shapes and sizes must be provided. They may be divided broadly into three classes, according to the shape of the "nose" or "bit" which holds the work, viz., flat, or square, Fig. 314, (*a*); round or hollow, Fig. 314, (*e*) and (*f*); and angle or vee, Fig. 314, (*g*). All tongs should be properly fitted to the work they have to hold, and should come in contact with it throughout the whole length of the jaw, Fig. 314, (*b*). They must not be too open, as in Fig. 314, (*c*), nor yet too close, as in Fig. 314, (*d*), or the work cannot be held securely. To relieve the hand of the smith from the constant pressure which would otherwise have to be exerted on the tongs when holding the work, a ring is fitted over the handles or "reins," and may be driven up until tight, being released by a blow from the hammer, or by striking the small end of the tongs upon the anvil, when the work is complete. The anvil, or pick-up tongs, or "smith's pliers," Fig. 314, (*h*), are not intended for gripping work when forging, but merely for picking up anything, or for tempering, etc. They are always kept near the anvil, all other tongs and tools being stored in a rack when not actually in use. The clip tongs, Fig. 314, (*i*), are necessary for holding flat bars from the end, and bill tongs, Fig. 314, (*j*), are used for angle pieces and bent work. When forging bolt heads, collared pieces, nuts, etc., bow tongs, Fig. 314, (*e*), are required, and several modifications of this principle are in frequent use when making or repairing hammers, chisels, flatters and other tools, as shown in Fig. 314, (*k*).

CHAPTER XXXI.

FORGING MACHINERY—POWER HAMMERS—STEAM HAMMERS—PRESSES, ETC.

FROM the earliest times attempts have been made to economise human labour by the introduction of some form of

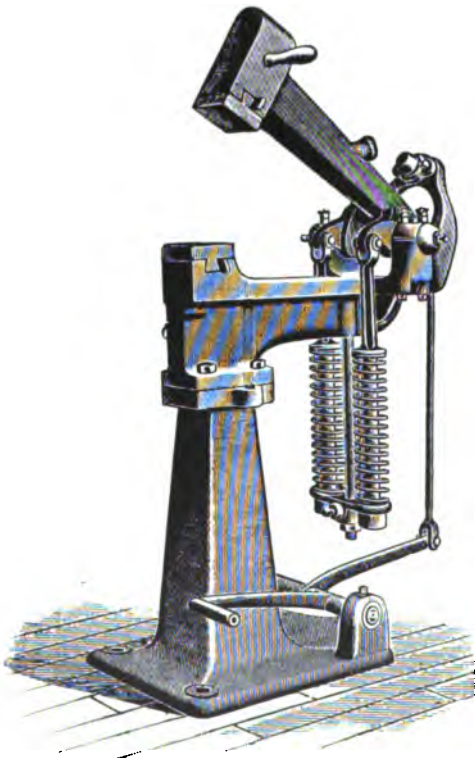

FIG. 315.—“ Oliver,” or Foot-power Hammer.

mechanically operated hammer. The old-fashioned “*Oliver*,” worked by the foot, and intended to dispense with the striker, still survives to some extent for certain classes of work. A modern type of this machine which has done good service in iron plate workers’ and coppersmiths’ shops is shown in Fig. 315. The hammer, which weighs 20 lbs., is raised by spiral springs, and the blow is given by smartly pressing down the pedal.

The same principle has been developed in a very ingenious manner in the *parallel hammer* invented by Mr. W. Blacker, and made by the Mechanical Hammer Co., of Stalybridge. In its simplest form, Fig. 316, it is intended to dispense with the services of a striker, and is

worked by depressing the foot-rail which extends round the anvil; but it is also arranged to be operated by power, Fig. 317,



FIG. 316.—Parallel Hammer for Foot Power.

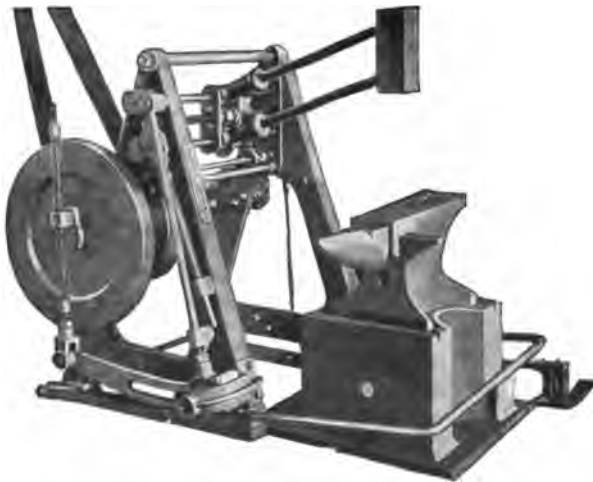

FIG. 317.—Power-driven Parallel Hammer.

and in this form is one of the most convenient and efficient machines yet introduced for the purpose. The hammer head swings on a parallel motion, by which it is always kept in

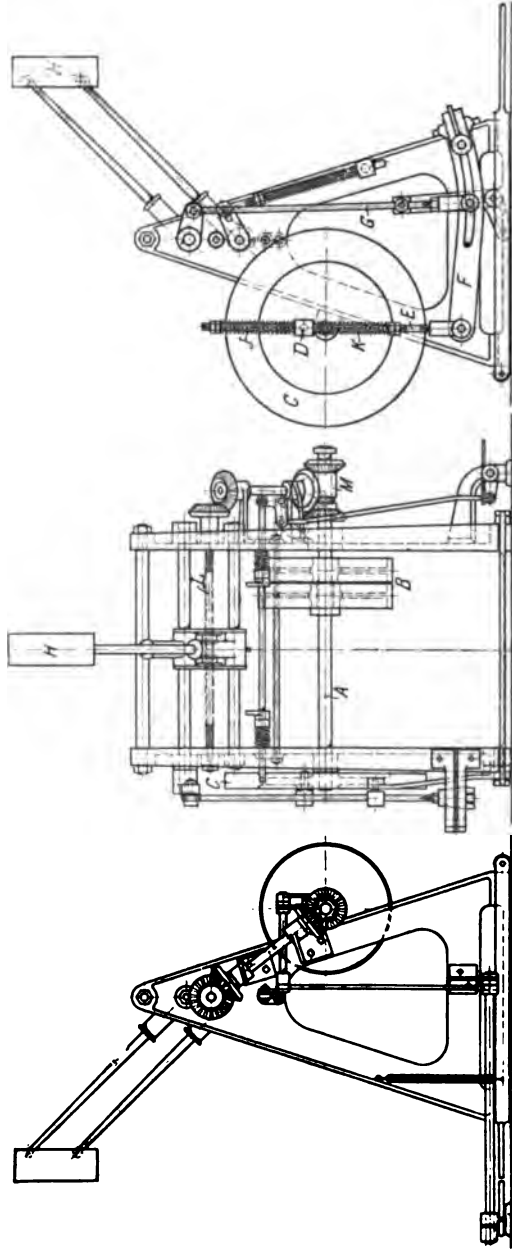

FIG. 318.—Power-driven Parallel Hammer.

a vertical position, and when not at work, it is thrown back out of the way and retained at the top of its stroke by means of two powerful springs. As will be seen from Fig. 318, the shaft, A, driven by means of fast and loose pullies, B, carries a flywheel, C, in which is fixed a crankpin. Motion is imparted to one end of a slotted lever, F, by a rod, E, connected to a block, D, on the crankpin, cushion springs, J and K, being employed to give the necessary elasticity to the blow of the hammer. A die in the slot of the swinging link, F, is coupled to the parallel motion of the hammer by the rod, G, and the stroke of the hammer may be adjusted by moving the die along the slot. For this purpose the rod, G, is held in the required position by a bell-crank lever connected to the foot rail which surrounds the anvil. A light or heavy blow, or a succession of blows, can thus be given at will by depressing the foot-rail, on releasing which the hammer immediately comes to rest. A unique feature is the lateral traverse motion, by means of which the head may be moved right or left to any position over the anvil. At the end of the shaft, A, opposite to the fly-wheel is a reversing mechanism of three bevel wheels, driving through the short shaft and the mitre gears the traversing screw, L. The clutch for throwing into gear one or other of the bevel wheels, M, is operated from the foot pedal seen on the right, on releasing which the hammer remains in the position to which it has been moved.

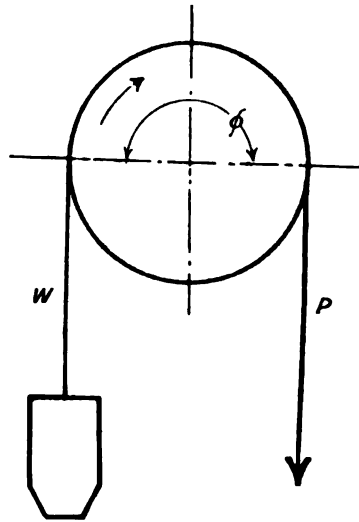

FIG. 319.—Principle of Drop Hammer.

Power Hammers.—For much of the heavier work which has to be executed in the smith's shop at the present day, a power hammer, or better still a light steam hammer, is indispensable. Several very handy types of power hammer, driven by belt from a line of shafting overhead, have been evolved. In one arrange-

ment, known as the *Drop Hammer*, a heavy tup is lifted by mechanical means to any height within the capacity of the machine, and is allowed to fall vertically between guides. This is effected in a very simple manner, Fig. 319, by attaching the tup to one end of the leather belt, which passes round a constantly rotating pulley. Suppose a force P to be exerted upon the free end of the belt, the tup will be raised by means of the friction between the belt and the pulley. When the pull, P , is discontinued, the belt slips and the weight, W , falls. The relation between W and P is given by the equation

$$W = Pe^{fQ},$$

where e = the base of hyperbolic logarithms = 2.718, f = the coefficient of friction, and Q = the angle embraced by the belt on the pulley. Taking $f = 0.4$, and $Q = 180^\circ$, it is found that $W = 3.5P$. It is therefore evident that the pull P , which can be exerted directly by hand, will suffice only for very small sizes of hammer. The arrangement indicated in the sketch is also open to the objection that the weight of the free end of the belt and the handle attached to it would occasion considerable friction between the belt and the pulley during the fall of the tup, thus reducing the effect of the blow, and rapidly wearing out the belt.

This is overcome by the employment of a suitably arranged lifting mechanism, one of the best known examples of which is that made by Messrs. B. & S. Massey Ltd., of Manchester. Fig. 320, (a), is a general view of the lifter, with the lifting arms resting on the buffer, and in figures (b) and (c) the lifter, viewed from opposite sides, is shown with the arms raised. The friction drum, A, is keyed upon a continuously revolving shaft, driven by power. It is encircled by the friction band, B, which is of steel lined with hardwood blocks, and which, acting like a band brake, can be made to grip the drum by pulling the cord, D, attached to the lever, E, thus rotating the eccentric, C. When the tension in the cord is released, the band is disengaged by the spring, F. The lifting arms, G, are free to rotate in either direction on the shaft, and have the friction band, B, attached to them. From the cross piece connecting the lifting arms, the tup is suspended by a strong woven belt. A loose pulley, H, made in halves, is mounted between the lifting arms on the boss connecting them,

and is free to rotate in either direction. The buffer, J, acts as a stop for the arms in the extreme position at either end of the stroke. The action is as follows: When the cord, D, is pulled, the friction band is tightened, and made to grip the revolving

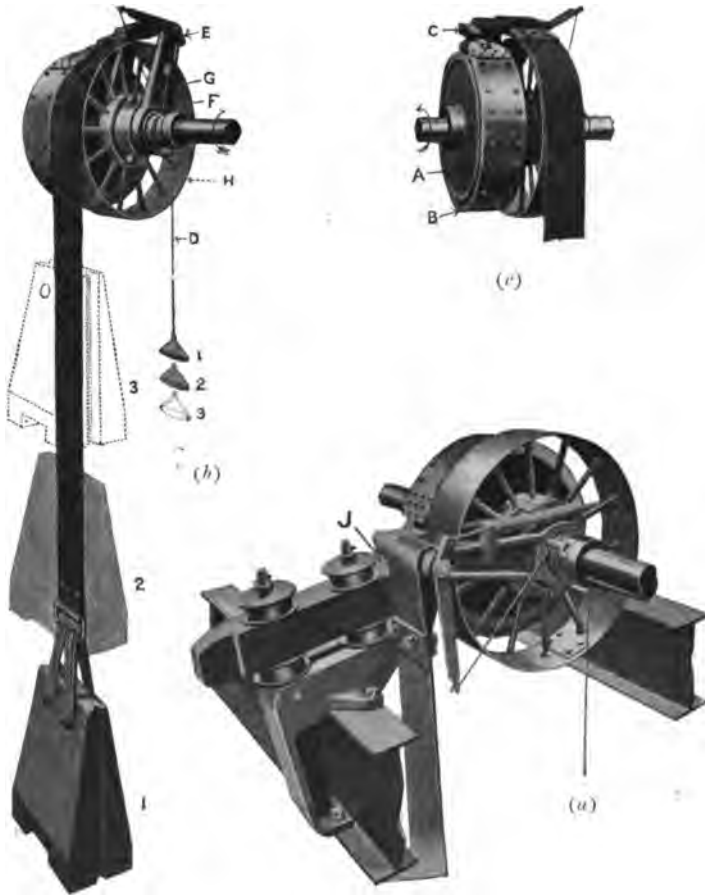

FIG. 320.—Lifter Mechanism for Drop Hammer.

drum, and the lifting arms, being connected to the band, rotate with it, and lift the tup. When the cord is released, the spring disengages the band from the drum, and the tup falls. A valuable feature of this system is the great sensitiveness of the control, which is obtained by automatically reducing the grip of

the friction band as the tup rises. The cord, D, is wound round the shaft, so that as the arms rotate in the lifting direction, carrying the operating lever, E, with them, the cord is automatically unwound, and the tension in it relieved. A constant pull must therefore be maintained on the cord to keep the band tight, and so prolong the rise of the tup. If the cord is pulled to a certain point and held there, the friction of the band is at once reduced

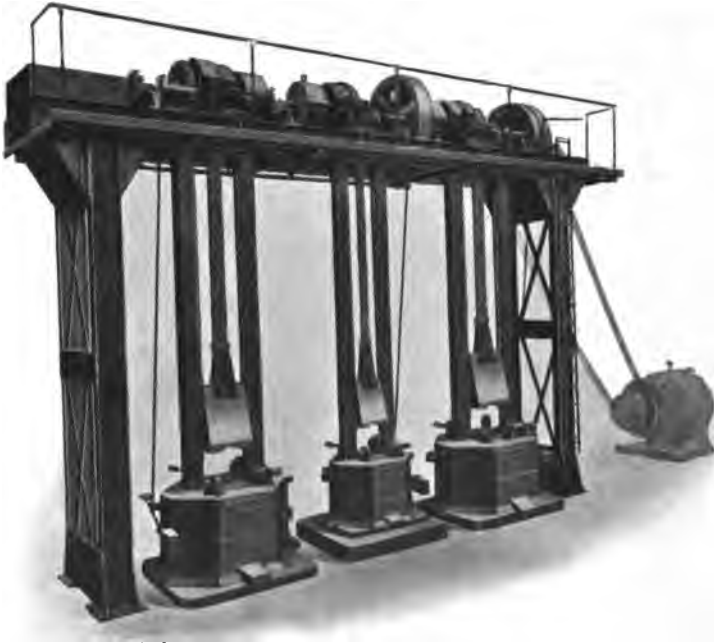

FIG. 321.—Battery of Motor-driven Drop Stamps.

until it is just sufficient to hold the tup suspended and no more ; for if the tup were to rise higher, the cord would at once become slack, and if, on the other hand, it were to fall in the slightest degree, the cord would immediately tighten, and cause the band to grip more firmly. The relation between the movement of the tup and that of the pulley cord is clearly shown by the numbered positions in figure (b), a light pull through a short stroke being all that is required to operate a heavy stamp. Hammers of this type are made with tups weighing from 3 to 80 cwts., and for

stamping in dies they are probably unequalled. Where a number of stamps are required, it is most convenient to arrange them in batteries, *i.e.*, in rows, the lifters being mounted on one main shaft, supported on girders carried by stanchions. The lifters are thus quite independent of the anvil blocks, and therefore free, to a great extent, from the vibration and jar of the blow. The mainshaft may be driven by belting or gearing, or very conveniently from an electric motor by means of a belt to preserve the elastic nature of the drive. An exceedingly neat arrangement of this kind, as carried out by Messrs. B. and S. Massey, is shown in Fig. 321. In this case, the 7-cwt. preparing stamp in the centre is used for roughing out work previous to stamping in dies, or for cutting off stampings from the bar, whilst left and right respectively are 20-cwt. and 15-cwt. stamps for die work.

Friction drop stamps are not so well adapted for forging where blows are required in rapid succession. An attempt has been made to obviate this defect in the *Board Stamp* shown in Fig. 322. Here the tup, T, is securely attached to a wooden board,

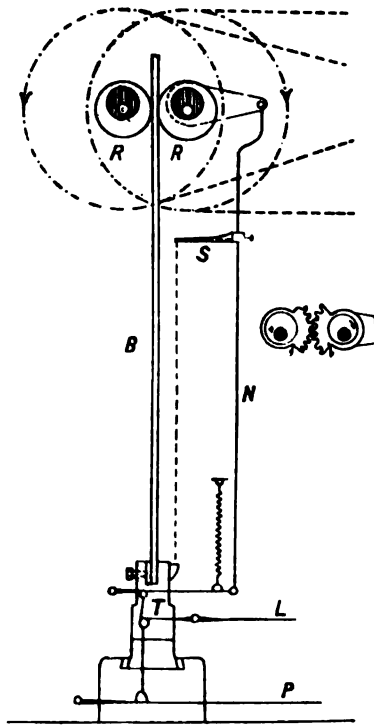

FIG. 322.—Principle of Board Stamp.

B, which runs between friction rollers, R, R, driven by open and crossed belts respectively from the line shaft. One of the rollers runs in eccentric bearings, by partially rotating which the board may be nipped between the rollers, giving a "friction rack and pinion" action for raising the tup. On rotating the eccentric bearing in the opposite direction, the driving action ceases, and the tup falls. It is thus possible to allow the tup to fall from a greater or less height, giving heavy or light blows as required.

When working with heavy blows, however, the speed must necessarily be very slow, which is characteristic of almost all



FIG. 323.—Board Stamp.

drop hammers. To economise time as far as possible, the lift is made self-acting, the rollers being caused to press upon the board by means of a weight or spring. The blow is given by moving

a hand lever, L, or pressing down the foot pedal, P, connected to it, as may be most convenient in working. On releasing the lever, the weight or spring comes into play, and the tup is at once raised. The lift is limited by allowing the tup when nearing the top of its stroke to strike the tappet, S, which is coupled to the



FIG. 324.—Ryder Forging Machine.

rod, N, of the hand gear. An adjustable catch, which engages with a rack or notched plate on the standard, is provided for holding the tup suspended at any height, to allow of adjusting the work on the anvil. In the hammer made by Messrs. Thwaites Bros., Ltd., Fig. 323, the weight of the tup varies from 8 to 20 cwts., and the velocity of impact on delivering

the blow may reach from $2\frac{1}{2}$ to 4 ft. per second. With the object of increasing the speed of working, it has been sought to maintain a positive connection between the driving shaft and the tup, and in the second class of power hammer, the crank and connecting rod mechanism, or its equivalent the eccentric, has been generally adopted. This is seen in its simplest form in



FIG. 325.—Section of Ryder Forging Machine.

Ryder's forging machine, Fig. 324, in which a number of small hammers working in vertical guides are arranged side by side in the same frame, and are operated by cranks or eccentrics on a common shaft which is driven by power in the usual way (see also section, Fig. 325). The machine runs at a high speed, and is particularly suited for swaging or drawing down processes as required in the manufacture of bolts, and similar small pieces. The position of the bottom tool may be adjusted by a screw to give the diameter required, and the work, which is held in tongs, is rotated and fed forwards by hand, and may be passed on from one set of dies to another until the whole series of operations is complete. For a hammer of any but the smallest size, a direct connection between the crank and the tup is, however, inadmissible, as with crank and connecting rod mechanism, the *velocity of the reciprocating piece at the end of the stroke is zero*, which makes it impossible to give a blow in the strict sense of the term. This will be clear from the diagram Fig. 326, (a), in which the crank and connecting

rod mechanism is shown at ABC. The velocity of the uniformly rotating crank pin, B, is set off at BD, to a scale of feet per second to an inch, and through point D, the velocity circle is described from A as centre. Producing the given position of the crank, AB, to intersect the velocity circle in D, a line, DE, is drawn parallel to the connecting rod, BC, to cut the horizontal through C in E. The distance, CE, then represents the velocity of the reciprocating piece or tup to which

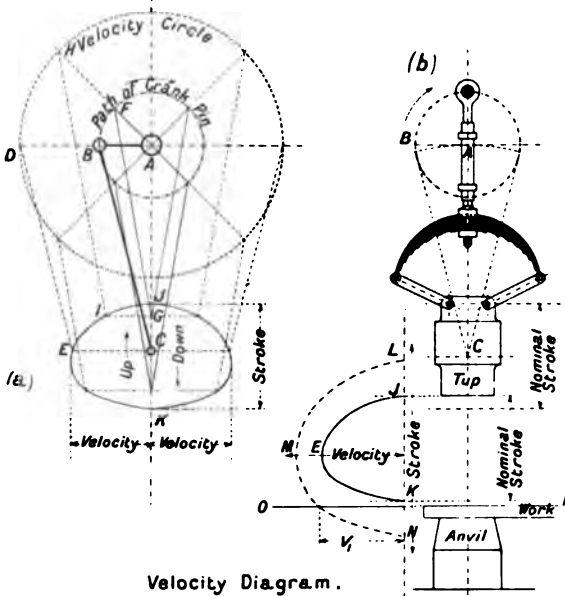

FIG. 326.—Velocity Diagram for Power Hammer.

C is coupled, and may be read off to the same scale employed in setting off BD. Repeating the construction for a number of positions of the crank, the curve, JIEK, may be drawn to show the variation in the velocity of the reciprocating piece throughout the stroke. At each end of the stroke, JK, the velocity is zero, as stated. It is therefore evident that an elastic connection must be inserted between the crank mechanism and the hammer, which may be effected either by means of springs of steel, or of buffer cylinders working with compressed air. Suppose the connection to be made by means

of a steel plate spring, as shown in outline at (b), with the crank rotating very slowly the velocity of the tup will be the same as if coupled to a rigid connecting rod. The velocity at any instant during the stroke is therefore shown by the diagram JEK transferred from (a), and as J and K are the highest and lowest positions respectively, the tup does not

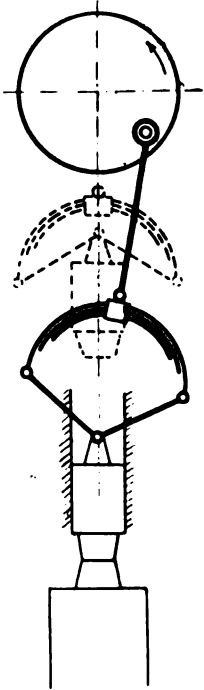

FIG. 327.—Principle of Shaw Hammer.

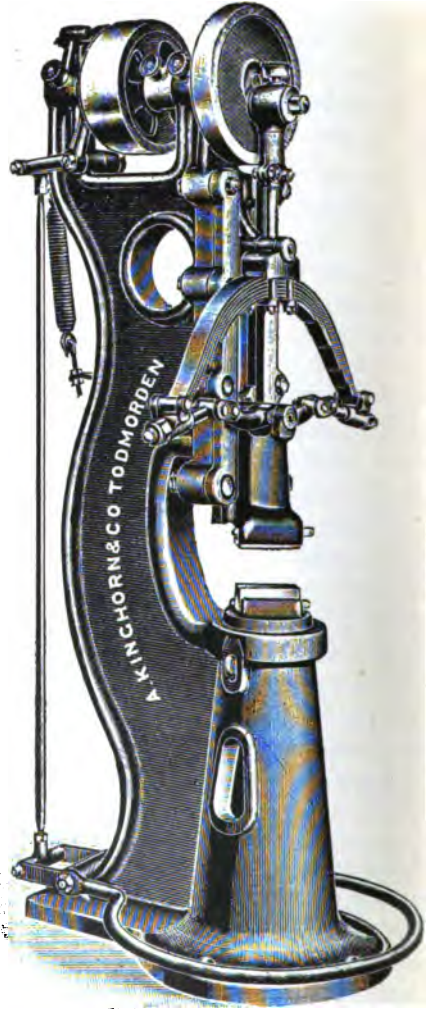

FIG. 328.—Spring Power Hammer.

even come in contact with work of the thickness shown. As the speed of rotation of the crank is increased, the tup is thrown by the action of the spring further and further beyond the points J

and K. The length of stroke may thus be increased to LN for which the velocity diagram is LMN, and if OP be the upper



FIG. 329.—Spring Power Hammer.

surface of the work, the velocity V_1 of the tup at the instant of striking the blow may be measured off to the intersection of OP with the curve.

In the *Shaw Hammer*, Fig. 327, largely used for light work

such as forging knife blades, cutlery, etc., the tup is suspended by strong leather straps from the ends of a steel plate spring of almost semicircular form, which is coupled directly to a crank mechanism driven by power. This type of hammer is capable of working at a high speed, and in proportion to its size, of giving very heavy blows, but the intensity of the blow can only be varied by changing the speed of rotation.

A good example of a hammer of this description, built by Messrs. A. Kinghorn & Co., Ltd., of Todmorden, is illustrated in

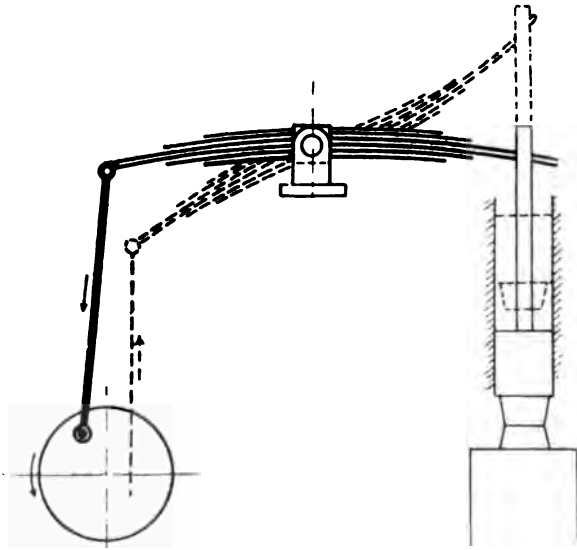

FIG. 330.—Principle of Spring Lever Hammer.

Fig. 328. The tup weighs 50 lbs., and the hammer will give from 100 to 300 blows per minute, control being effected by a foot treadle acting upon a clutch motion on the driving shaft, as will be seen from Fig. 329. The ends of the spring are connected to the head or tup by means of toggle links, which ensure flexible working. The anvil faces are set at an angle, so that long bars may be dealt with. The hammer requires about $\frac{3}{4}$ H.P. to drive it.

A modification of this type of hammer in which a *Spring lever* is employed is shown diagrammatically in Fig. 330. The lever

is constructed in the form of a steel plate spring, with the buckle as fulcrum. One end of this spring is connected by links to the tup, which slides in vertical guides on the front of the standard or frame. To the other end of the spring is coupled the connecting rod, which receives motion from a crankshaft driven by belt in the ordinary manner. The throw of the crankpin or eccentric may be adjusted, and in this way blows of varying intensity may be delivered. Suppose the tup to be in contact with the anvil, the crank end of the spring is just commencing to move downwards. Before the tup begins to rise, both ends of the spring will bend downwards until the inertia due to the weight of the tup is overcome. Towards the end of the stroke, the crank end of the spring is moving slowly, allowing the opposite end to straighten itself, thus increasing the velocity of the tup. When the crank end commences its upward stroke, the tup is still moving upwards, and is retarded and finally brought to rest by bending upwards its end of the spring. When the whole of the energy previously stored up in the moving mass has been transferred to the spring, the tup is free to fall, its velocity being due not only to its own weight, but also to the pressure exerted by the spring in straightening itself, and a powerful blow is delivered. Some deterioration of the spring is liable to occur on account of the rapidly repeated and alternate bending to which it is subject, and fracture may result from this cause. This led to the introduction of the *Pneumatic Hammer*, Fig. 331, in which the tup is attached to an airtight piston, working in a vertical cylinder which slides between guides, and is driven by crank and connecting rod motion from the shaft of the machine. During the upward stroke, commencing with the tup resting upon the anvil, a partial vacuum is created above the piston, and the external pressure of the atmosphere raises the tup. Before the upstroke

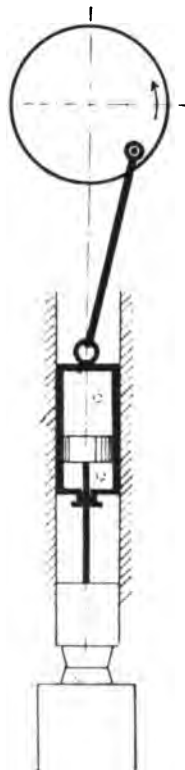

FIG. 331.—Principle of Pneumatic Power Hammer.

Before the upstroke

of the latter is completed, the cylinder commences to return, and the air, being powerfully compressed, drives the tup

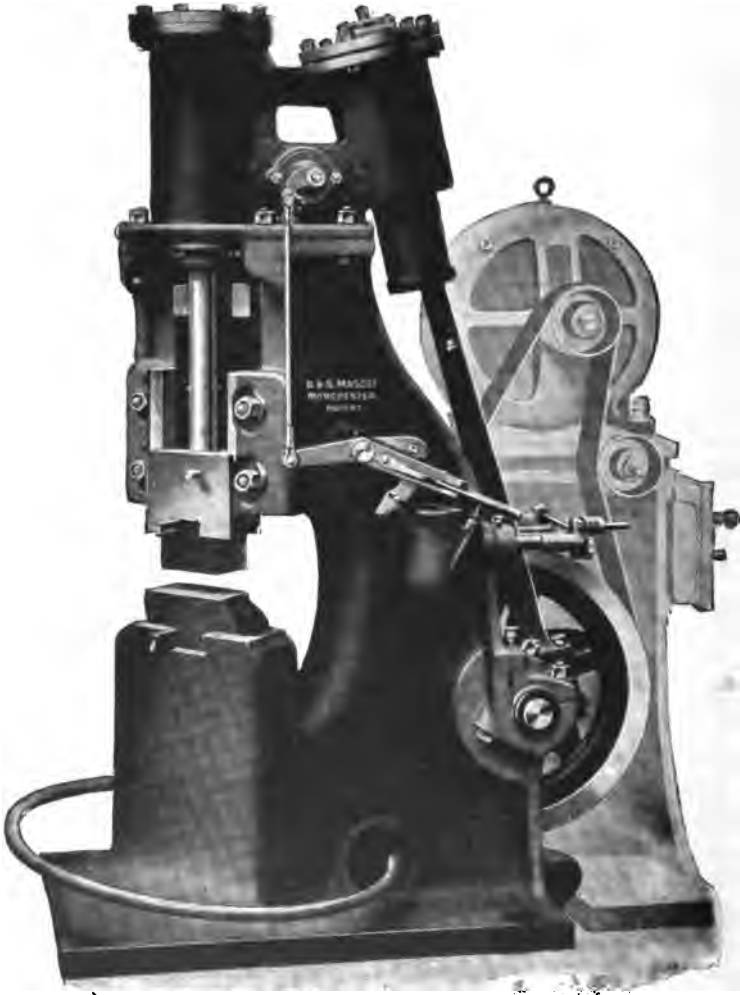

FIG. 332.—Pneumatic Power Hammer.

downwards with considerable velocity, thus giving a heavy blow. An air valve opens out a communication between the ends of the cylinder, and enables the pressure of the air to be

regulated to suit requirements. When the valve is closed, the full pressure is maintained, and the heaviest blows are delivered, but with the valve fully open, the air is permitted to escape, and the hammer ceases to work. Blows of any degree of intensity between these limits can therefore be obtained by merely opening the valve to the desired extent. This device permits the speed of working to be varied between wide limits, say from 10 to 300 blows per minute. The rotation of the vertical spindle, to which the valve is fixed, also applies a brake to the tup, so that the latter may be held at the top of its stroke until the work has been adjusted on the anvil, the air escaping at the open valve meanwhile.

As ordinarily constructed, the suction-lifted hammer is feeble and sluggish in its action, and the tup must be light in proportion to the cylinder diameter. This is due to the fact that suction and pressure follow each other in the same cylinder, the tup, as explained, being raised by suction and thrown down by pressure. The suction in lbs. per square inch must necessarily be very small, as when the vacuum is greatest there must still be sufficient air present to give the pressure for throwing down when the pump reverses. Similarly, the pressure for throwing down can only be low, otherwise the suction on the return stroke would be too feeble to lift at all. Messrs. B. and S. Massey, Ltd., of Manchester, have introduced a pneumatic power hammer in which the defects named are obviated by the employment of a separate pump, operated by crank and connecting rod from a power-driven shaft carried in bearings at the rear of the standard, as will be seen in Fig. 332. The method of working is explained in Fig. 333. The cylinders and valve chamber, with the passages connecting them, are shown in section at (a), (b), and (c). The passage, A, establishes communication between the top and bottom of the pump cylinder. The top and bottom ends of the pump and hammer cylinders are connected by means of the passages B, and C, respectively. The valve piece shown separately at (d), contains two valves, each consisting of a thin steel disc, closed by a light spring. This valve piece is controlled by a hand lever, which may be moved into the positions 1, 2, 3, and 4, in Fig. 334. In position 2, the passage, A, is fully open, as at (a), and if the pump is running, the air circulates freely from top to bottom and *vice versa*, without affecting the hammer.

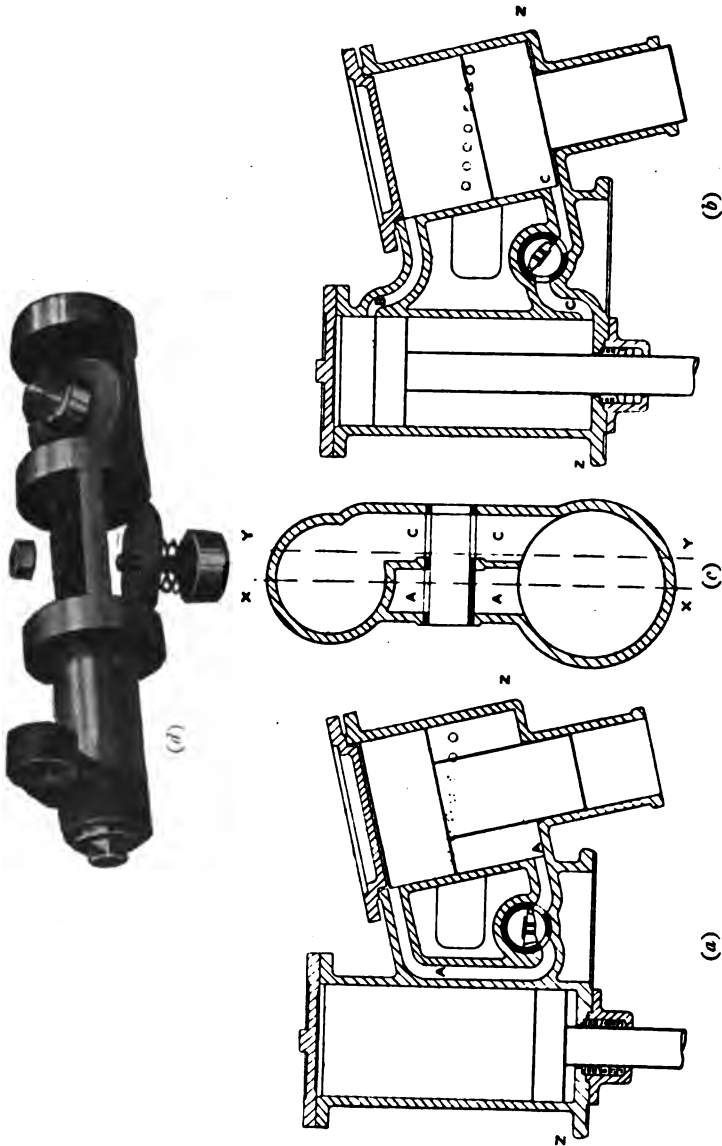

FIG. 333.—Details of Cylinders and Valve Chamber.—Pneumatic Power Hammer.

As the lever is moved from 2 to 3, the passage, A, is gradually closed, and a portion of the air is forced alternately through the passages B and C, raising and depressing the hammer piston.

When position 3 is reached, A is closed entirely, and the whole of the air is forced into the hammer cylinder, thus giving the maximum blow. In position 1, the small valves in the valve piece are brought into operation, allowing air to pass down passage A on the up stroke of the pump, and along passage C into the hammer cylinder on the down stroke, but not in the opposite direction. The lower part of the hammer cylinder

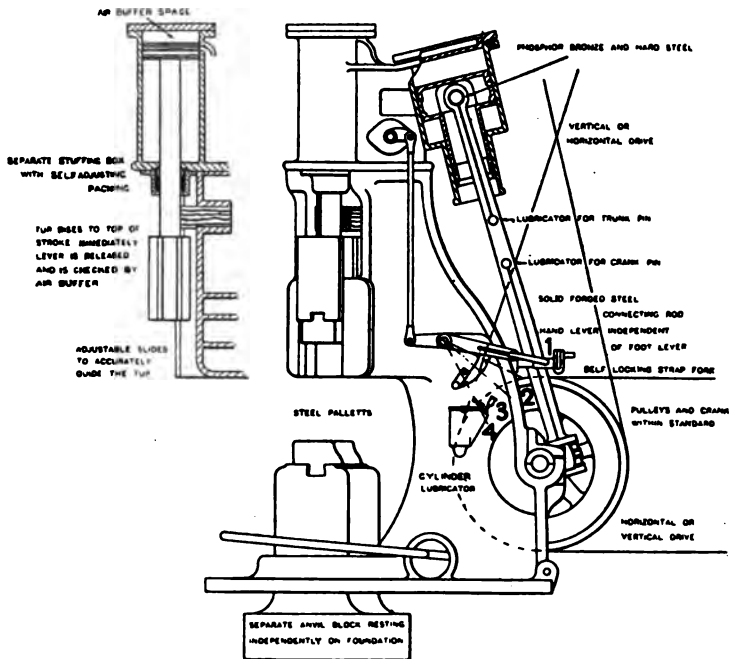

FIG. 334.—Diagram of Working.—Pneumatic Power Hammer.

is thus filled with compressed air, and the hammer is "held up" at the top of its stroke. Excessive pressure is prevented by allowing any surplus air not required for holding up to escape by way of the passage A. In position 4, the action is reversed, a partial vacuum being formed below the hammer piston, causing the hammer to be held down firmly on the anvil, and enabling it to be used as a vice. The hammer is thus controlled entirely by the movement of one lever actuating a single valve, and heavy or light blows may be struck at will. In the Massey hammer, as

shown by the indicator diagrams in Fig. 335, as the pump piston approaches each end of its cylinder, the other end is filled with air at atmospheric pressure, and consequently as soon as the motion is reversed, effective pressure is produced to force the hammer piston in the opposite direction. The hammer can thus be made as powerful as the steam hammer of equal falling weight working with a steam pressure of 60 lbs. per square inch.

The Steam Hammer.—There would seem to be little doubt that for general work the steam hammer, although wasteful in regard to the amount of steam consumed, is unapproached for adaptability, ease of manœuvring, and freedom from breakdown. In the original steam hammer invented by Nasmyth, the steam pressure was employed solely in lifting the tup, which, on exhausting the steam, was allowed to fall by its own weight

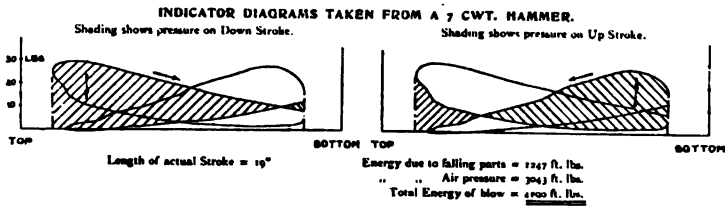

FIG. 335.—Indicator Diagrams from Pneumatic Power Hammer.

merely, or in other words, the hammer was single-acting. It was soon found that by working with *top-steam*, the velocity of fall and therefore the force of the blow, could be considerably increased, especially in the case of hammers of small and moderate sizes. But the practice still remains of designating the size of a steam hammer by reference to the weight of its falling parts. Thus, a very convenient size for general use in the smithy is a 10-cwt. hammer, which means that the piston, piston rod and tup complete weigh together 10 cwts. Forge hammers vary in size from 4 tons up to 50 tons or more, but the larger sizes are now being displaced by forging presses, for reasons already explained. The application of "top steam" has led to the introduction of a most effective type of quick-acting steam hammer, capable of giving 400 to 450 blows per minute in the smaller sizes when automatic gear for working the steam valve is employed. With a 7-cwt. hammer working with steam on both sides of the piston, the velocity of impact is probably ten times as great as that due

to gravity alone, and as the energy stored is proportional to the square of the velocity, it follows that to deliver a blow of the same intensity, a single-acting hammer of $\frac{7 \times 10 \times 10}{20} = 35$ tons would be required.

Much has been written concerning the "*force of the blow*," and the equivalent "*dead pressure*." Experiment has proved that the effect of steady pressure is, however, not at all the same as that of a blow. To produce a given change of shape by means of a blow requires, as a rule, a much greater expenditure of energy than by steady pressure. In either case, much depends upon the nature of the work and the time occupied in its actual performance. The work done at one blow occupies an exceedingly short space of time, and the resistance due to the disturbance of the molecules of the substance operated upon, is consequently much greater than that offered to a steady pressure acting for a much greater length of time. With steady pressure, work is done at a velocity of from 0.3 feet to 3 feet per second, and by a blow, as with a hammer, at from 10 feet to 30 feet per second. The greatly reduced velocity in the first case, renders it possible to transmit the effects of the pressure into the very interior of a piece of work of large diameter, thus causing a uniform flow of the metal. A blow, on the other hand, by reason of its short duration, makes itself felt on the exterior only, the effect scarcely penetrating to the centre. Experiment has demonstrated that the same alteration of form is produced with the same expenditure of work, whether a heavy weight falling from a small height, or a small weight falling from a greater height, is employed, provided that the product of weight into height remains the same, *i.e.*, $W \times h = \text{a constant}$, the velocity of impact, v , being $= \sqrt{2gh}$. It is, of course, essential that the objects operated upon should be exactly similar, especially as regards the shape and extent of the surface upon which the blow is received, as the depth and configuration of the impression produced upon a flat surface differs altogether from that given to a surface of rounded or irregular form, the energy of the blow being the same in each case. The duration of the blow has been the subject of much investigation, and it has been proved beyond question that the time during which contact takes place is extraordinarily short. A moderately smart blow upon the anvil with an ordinary hand

hammer does not last longer than 0.00027 second, and a heavy blow probably not more than 0.00019 second. The time of contact is undoubtedly less the greater the velocity on striking. The nature of the material operated upon is naturally an important factor. With soft metal such as lead alloy, Fischer found that the time of contact may amount to 0.05 second, with copper 0.005 second, and when forging mild steel 0.001 second. In any case, the duration of the blow is so exceedingly small that the resulting pressure must of necessity be enormously great. In practice, a far from negligible portion of the total energy developed is wasted in producing vibration of the anvil and foundations. The blow of a heavy steam hammer, as is well known, may be felt some distance away, and the mechanical work expended in setting up vibrations over such an extensive area must be very considerable. The degree of penetration of a blow has been shown to depend upon the time of its duration. It follows that where great penetration is required, a heavy hammer falling through a small height will be most effective, whereas if it be desired to operate on the surface only, a light hammer moving at a high velocity will be found preferable. The size and weight of the hammer should therefore be carefully chosen to suit the nature of the work in hand.

To estimate the effect of the blow, either the space moved over after striking the work, *i.e.* the depth of the indentation = d feet, or the time during which the tup and the work are in contact = t seconds, must be known, and in practice these quantities are both extremely difficult to obtain even approximately. When the depth of the indentation is known, the pressure may be found by the well-known formula, in which W = weight in tons of moving parts of hammer, v = velocity of impact in feet per second, d = depth in indentation in feet, P = maximum total pressure on the work in tons, F = average total pressure on work in tons, g = gravitation unit = 32.2 feet per second, S = space fallen through in feet, t = time occupied in making indentation in seconds, t_1 = time of lift in seconds, and t_2 = time of fall in seconds. Then

energy stored up in falling weight = $\frac{Wv^2}{2g}$, and energy absorbed in

the blow = Fd . Therefore $Fd = \frac{Wv^2}{2g}$, and $F = \frac{Wv^2}{2gd}$. Assum-

ing the intensity of pressure to diminish at a uniform rate as the

work is absorbed, $P = 2F$, a ratio which is not likely to be exceeded, but which depends largely upon the elasticity of the material. If the duration of impact is known, then momentum $\frac{Wv}{g} = Ft$, and $F = \frac{Wv}{gt}$.

Rating of Steam Hammer.—In practice, makers sometimes specify the power of a steam hammer by reference to some arbitrary rule for calculating the "force of impact," which, in one such case, it is stated may be found thus:—

$$\text{Approximate force of impact} = W \times v \times 3,$$

in which, W = total falling weight in tons, obtained by adding to the actual weight of the parts the steam pressure on the piston, v = velocity in feet per second = $8 \sqrt{\text{stroke in feet}}$, and 3 = a constant determined by experiment. Thus, for a 25-cwt. hammer (*i.e.* one in which the weight of the piston, piston rod and tup = 25 cwts.) having a steam cylinder 16 inches diameter \times 3 feet stroke, and working at a mean steam pressure of 50 lbs. per square inch,

$$W = \frac{25}{20} + \frac{16 \times 16 \times .7854 \times 50}{2,240} = 5.73 \text{ tons},$$

and the approximate force of impact is then = $5.73 \times 8 \times \sqrt{3} \times 3 = 240$ tons. It is not quite clear what useful purpose is served by thus attempting to arrive at the "force of the blow." It is sometimes, though erroneously, assumed that this figure may be used for comparison with a press capable of doing the same work. At best, it can only be regarded as a convenient expression for the nominal power of a hammer, and it is practically impossible to give any formula capable of furnishing definite information, as the following example will show. A 5-ton steam hammer has a cylinder 27 inches diameter, with a stroke, $S = 5$ feet, and the mean effective pressure of steam is 70 lbs. per square inch. The force producing acceleration of the hammer is equal to the sum of its weight and the total steam pressure on the piston, or

$$5 + \frac{27 \times 27 \times .7854 \times 70}{2,240} = 5 + 17.8 = 22.8 \text{ tons}.$$

$$\text{Acceleration} = f = \frac{\text{force}}{\text{mass}} = \frac{22.8}{5} \times 32.2 = 147.4 \text{ ft. per sec. per sec.}$$

Then velocity of the moving parts at end of stroke = v may be found from the equation $v^2 = 2fs$, *i.e.*

$$v = \sqrt{2 \times \text{acceleration} \times \text{stroke}} = \sqrt{2 \times 147.4 \times 5}$$

$$= \sqrt{1,474} = 38.4 \text{ ft. per sec.}$$

Now momentum = $\frac{Wv}{g}$, = $\frac{5 \times 38.4}{32.2}$, and average force of the blow = F = change of momentum per sec. = momentum \div time in secs. = $\frac{Wv}{gt}$. To proceed further, it is necessary to know the time, t , during which the hammer is brought to rest after first coming in contact with the metal. This will vary very greatly according to the material, the area and shape of the surface which receives the blow, the temperature at which the operation is conducted, etc., so that it is extremely difficult to form even an approximate estimate of the duration of the blow. It may be said that the time may amount to anything from 0.001 to 0.007 of a second, according to circumstances. Taking the former value

$$F = \frac{5 \times 38.4}{32.2} \div 0.001 = \frac{5 \times 38.4}{32.2 \times 0.001} = 6,000 \text{ tons.}$$

If, however, the latter value of t should prove correct, the average force would suffer a considerable reduction, and would only amount to 853 tons.

Again, it is sometimes proposed to calculate the "force of the blow" from the amount of energy stored up in the moving parts.

The kinetic energy of the falling weight is known to be = $\frac{Wv^2}{2g}$,

which, at the instant of striking the blow = $\frac{5 \times 38.4 \times 38.4}{2 \times 32.2}$

= 114.5 foot-tons. It is next assumed that this energy is expended over a distance equal to the depth of the impression or indentation produced by the blow, which, expressed as a fraction of a foot, may be written d . If F = average force of the blow in tons, then the work done in producing the impression referred to = $F \times d$, which is assumed to be equal to the kinetic energy stored up in the moving parts, when $F \times d = 114.5$, or $F = \frac{114.5}{d}$.

It has been stated on good authority that for a hammer of the size referred to, and at the correct temperature for forging, it may be assumed that the moving masses are brought to rest within a space of $1\frac{5}{8}$ inch = $\frac{13}{8}$ foot. The average retarding force would then be = $114.5 \div \frac{13}{8} = \frac{114.5 \times 96}{13} = 845$ tons.

But here again an almost unsurmountable difficulty arises. It is probably wrong to assume that the whole of the space of $1\frac{5}{8}$ inch can be utilised for the compression of the forging. The elasticity of the foundations must absorb a considerable portion of the work expended in the blow. Experience has in fact shown that probably at least one-third of the work is lost in setting up vibrations.* This would leave for the case chosen about 1 inch for useful deformation of the forging. It will be seen that in the absence of reliable data, a correct treatment of the subject is scarcely possible. The best that can be done is to express the energy expended in the blow in foot-lbs. or foot-tons calculated for the instant of striking by taking the product of W (as found above) and the length of stroke in feet.

Any calculation of the pressure equivalent to a blow is therefore of little value, but in a certain case an attempt was made to deal with the matter in the following manner. Two exactly similar copper prisms $1\frac{1}{8}$ inches square \times $1\frac{9}{8}$ inches long were prepared, one of which on being subjected to the most powerful blow which could be delivered upon it by a 12-cwt. steam hammer, was found to have been shortened $\frac{1}{3}\frac{1}{2}$ inch. The second prism was then placed in the testing machine, and exposed to gradually increasing pressure until shortened to the same extent. The total load registered was found to be 92.7 tons. This is much in excess of the rule quoted above, which gives for the approximate force of impact ($= W \times v \times 3$) = 80 tons only. The energy at the instant of striking the blow was found to be 5 foot-tons.

It is of considerable interest to investigate the relation which should exist between the total pressure on piston and weight of moving parts to render possible a given speed of working. For this purpose, it is convenient to express the total mean pressure of steam on the piston in terms of the moving weight. Thus

* Paper on Power Forging by Gerdan and Mesta, American Soc. Mech. Engineers, 1911.

taking underside of piston, total mean pressure P_u may be written $= n_1 W$, when the total force acting upwards $= (n_1 - 1) W$, and the acceleration due to it $= (n_1 - 1) g$. Similarly for the top side of piston, the total mean pressure, $P_t = n_2 W$, the total force acting downwards $= (n_2 + 1) W$, and the acceleration during the fall $= (n_2 + 1) g$. Inserting these values for accelera-

tion in the usual formula $t = \sqrt{\frac{2s}{g}}$, the time $= t_1$ seconds, taken for the upward stroke $= S$ feet, may be found thus—

$$t_1 = \sqrt{\frac{2S}{(n_1 - 1)g}}, \text{ and the time of fall, } t_2 = \sqrt{\frac{2S}{(n_2 + 1)g}}.$$

In quick-acting hammers, it will be found that—

With W up to 3 cwts., and for 300 to 400 blows

per minute $P_u = 5$ to $6 W$.

With W up to 10 cwts., and for 150 to 300 blows

per minute $P_u = 4$ to $5 W$.

For larger hammers, of from 10 to 25 cwts. . . $P_u = 2.5$ to $3 W$.

Ditto, of from 2 to 5 tons $P_u = 1.8 W$.

Taking for example, the 10-cwt. double-acting steam hammer by Messrs. Thwaites Bros., Ltd., of Bradford, the diameter of cylinder $= 12$ inches, and of piston rod $= 5$ inches, the length of stroke being 27 inches. The areas of top and bottom sides of piston are therefore $= 118$ and 94 square inches respectively, and as the hammer is intended to work with a steam pressure of 60 lbs. per square inch, $n_1 = \frac{94 \times 60}{10 \times 112} = 5$, and $n_2 = \frac{118 \times 60}{10 \times 112} = 6$. The up-

ward stroke will therefore be made in a time $t_1 = \sqrt{\frac{2 \times 2.25}{(5-1) 32.2}} =$

0.187 , or say about $\frac{1}{5}$ second, and the time of fall, $t_2 = \sqrt{\frac{2 \times 2.25}{(6+1) 32.2}} =$

0.141 , or say about $\frac{1}{7}$ second. The time taken to make a double stroke is therefore $0.187 + 0.141 = 0.328$ second, and the number of blows per minute when working self-acting will be $60 \div 0.328 = 180$. The velocity of impact $= 0.141 \times (6 + 1) 32.2 = 31.7$ feet per second, which, as will be seen, is seven times that due to gravity, and the force of the blow will be forty-nine times as great as that due to a weight of 10 cwts. falling freely. A single-acting hammer of the same power would therefore weigh $49 \times \frac{1}{2} =$ say 25 tons.

The **Rigby, or single standard type of hammer**, is most suitable for general work in the smithy, the clear space round the anvil being a great convenience. Fig. 336 shows a 10-cwt. hammer of this pattern, made by Messrs. Thwaites Bros., Ltd., of Bradford, which has been largely adopted for the lighter kinds of engineer's



FIG. 336.—10-cwt. Rigby type Steam Hammer.

work. The valve gear is arranged for self-acting and hand working, and to give long, short, heavy, light, or dead blows as required. In this type of hammer, slides for guiding the tup are dispensed with, in order to allow as much space as possible for handling the work. To obviate any tendency to turn, two flats are planed on the piston rod, and the stuffing box, which is

made very deep for the purpose, and is of the same shape as the rod, serves as a guide. Care must be taken that the foundation

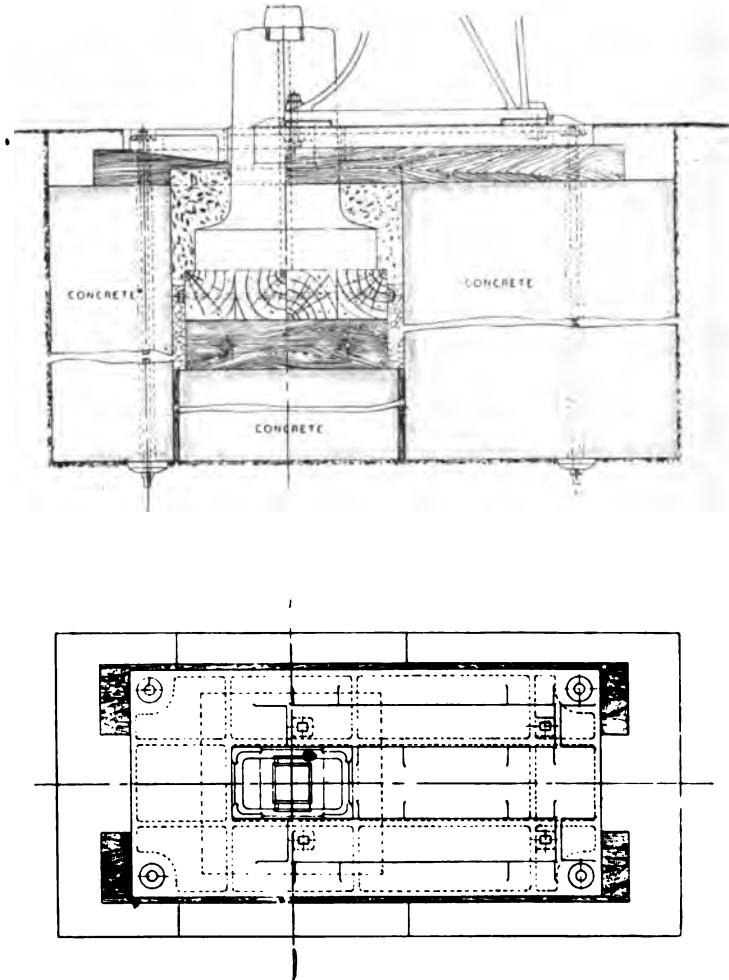

FIG. 337.—Foundations for Steam Hammer.

for the anvil block is entirely separate from that of the hammer. Each part should rest upon a timber frame, interposed between it and the bed of masonry or concrete to which it is secured, as shown in Fig. 337. The anvil block is of cast iron, and

its weight should be about eight times that of the moving parts, the foundation being correspondingly large and heavy. The tup and the anvil block are provided with dovetailed recesses in

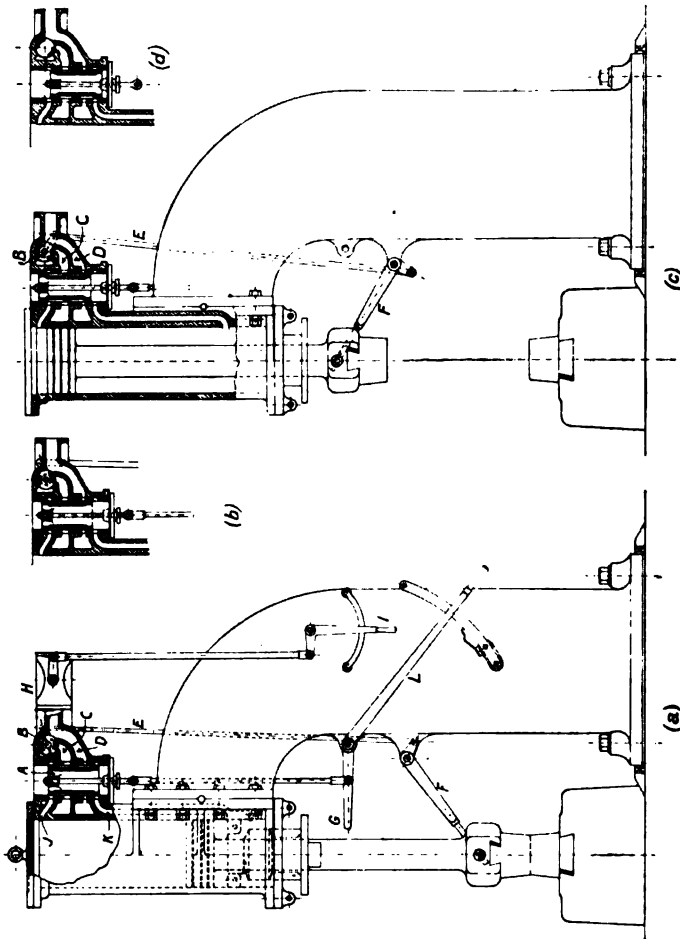

Fig. 338.—Automatic Valve Gear for Steam Hammer.

which the dies or "pallets" are fixed by means of flat keys or cotters. The pallets are made of tool-steel, and usually have flat faces, but these may readily be changed for "tools" of other shape if required. The hammer is provided with Messrs. Thwaites' patent automatic cut-off gear, Fig. 338, which

enables considerable economy in steam to be effected. The steam stop valve, H, is operated by hand lever, I, moving over a quadrant. The valve, A, for controlling the admission of steam

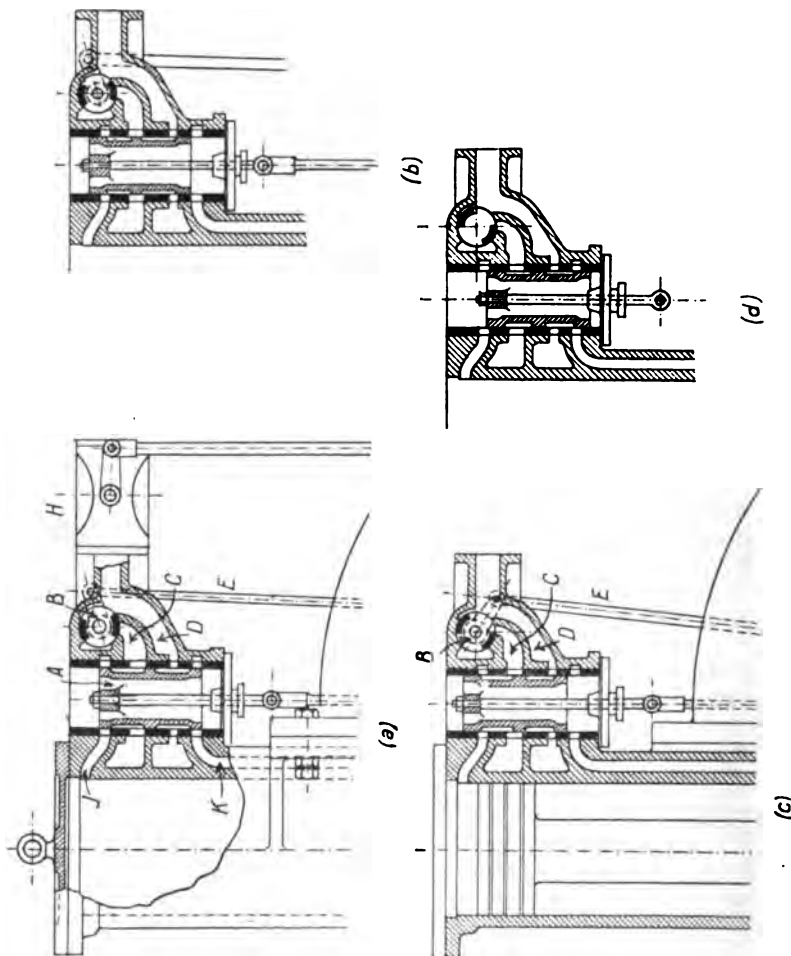

FIG. 339.—Automatic Cut-off Gear for Steam Hammer.

to the cylinder, must be balanced against steam pressure in order that it may be moved easily by hand. It is therefore made in the form of two pistons joined by a tube, connected to which by four wings is the central boss for the valve spindle. Live steam is admitted to the space between the two pistons, and according

to the position of the valve, is allowed to enter either the top or bottom steam port, as the case may be. The steam is exhausted into the valve chest, and escapes through the hollow valve, and out at the exhaust pipe at the top. The piston valve is moved directly by hand by means of the lever L, a movement being required for each blow, and with a skilful driver, the intensity of the blow may be varied within very wide limits. On raising the hand lever, L, steam is admitted below the piston, thus lifting the hammer, and when the hand lever is depressed, "top" steam is admitted above the piston, to give the downward stroke. The tripper lever, G, on the same shaft as L, is moved by the tup when the latter is near the top of its stroke, thus closing the working valve, A, and preventing the possibility of the piston striking a heavy blow on the cylinder cover. The patent cut-off gear (Fig. 339) is fitted with the object of reducing steam consumption by working expansively during both strokes. This is effected by means of the semi-rotating or Corliss valve, B, operated by a lever, F, to which motion is imparted by the tup. When the stop valve is open, steam under full pressure is constantly admitted to the port D. For lifting, port K is controlled by the working valve, A, from port D. As the piston rises to the top of its stroke, lever F moves the cut-off valve, B, to the position shown in (c), which opens the port C to full pressure from port D. On raising the working valve, A, steam is admitted to port J for striking the blow. On the descent of the piston-lever F moves the cut-off valve, B, to position shown in (a). When the piston has made about half stroke, steam is cut off from port J, and no more can be admitted unless the working valve, A, is raised to the position for "holding down" shown in (b). For holding up the hammer at the top of the stroke,

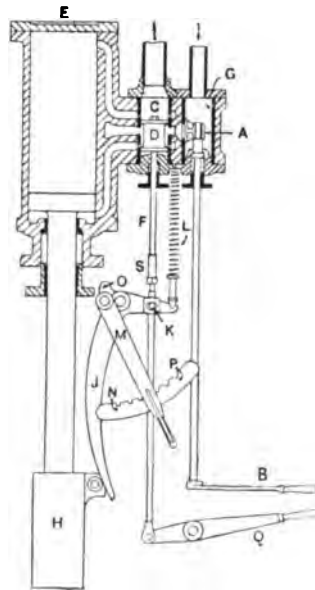

FIG. 340.—Self-acting gear for Steam Hammer.

As the piston rises to the top of its stroke, lever F moves the cut-off valve, B, to the position shown in (c), which opens the port C to full pressure from port D. On raising the working valve, A, steam is admitted to port J for striking the blow. On the descent of the piston-lever F moves the cut-off valve, B, to position shown in (a). When the piston has made about half stroke, steam is cut off from port J, and no more can be admitted unless the working valve, A, is raised to the position for "holding down" shown in (b). For holding up the hammer at the top of the stroke,

valve A is moved into the position shown in (d). Hammers above 10 cwts. are made with hand-worked valve motion only, but below that size, are usually fitted with both hand-worked and self-acting gear. The latter permits of continuous working at a much higher rate than is possible by hand. A simple form of self-acting gear made by Messrs. B. and S. Massey, Ltd., of Manchester, is shown in Fig. 340. This consists of the doubled-armed tappet lever, J, working on a movable fulcrum, O, the required motion being given to the curved arm during the upstroke by the friction roller on the tup. The short arm is connected at K to the valve spindle, F, and also to a strong spiral spring, L, which keeps the curved arm constantly pressed against the friction roller. The fulcrum of the tappet lever is carried upon the short arm of the quadrant lever, M, which may be held in any position on the notched sector, P, N. In this way, the fulcrum may be moved until only the straight portion of the long arm of the lever is presented to the friction roller on the tup, or until it is clear altogether, in which latter position the hammer may be worked by hand, as previously described. For the most rapid rate of working, with the full travel of the valve, the lever must be placed in the position N, from which it may be gradually "notched-up," reducing the travel of the valve more and more, and therefore diminishing the number of blows, until the position P is reached, when the self-acting mechanism is out of gear, and no movement of the valve takes place. For hand-working, the valve is moved direct by means of the lever Q.

Steam Stamp.—A special form of steam hammer is sometimes used for stamping in dies. As the hammer is double-acting, it has the advantage that blows can be struck more rapidly than with a drop stamp. Fig. 341 shows an example of a 10-cwt. steam stamp by Messrs. Thwaites Bros., Ltd., of Bradford, which has become known as the Enfield type, and is extensively employed in the production of all kinds of stampings required by gunsmiths, makers of textile and agricultural machinery, bicycle and motor makers, etc. The double frame gives great rigidity, and enables the tup to be accurately guided in V slides, which are points of considerable importance in die forging. It will be noticed that the anvil block is cast solid with the bedplate, so that when finishing dies are used, absolutely correct alignment of the die faces is secured. The design also provides ready

accessibility, and affords ample space round the dies for manipulating the work. In one form of steam stamp, the piston rod passes through the top cylinder cover, and is provided with a



FIG. 341.—Steam Stamp for Drop Forging.

volute spring buffer to take up the rebound of the tup after stamping.

Hot Saw.—For cutting off bars, cutting out gaps or sweeps, as in the case of crankshafts, etc., a very handy and almost

indispensable tool for the smith's shop is the hot saw, an example of which, made by Messrs. T. Ryder & Son, of Bolton, is given in Fig. 342. The saw is usually about 36 inches in diameter, and the spindle is arranged to run on ball bearings. The work rests in V blocks on a slide, which is fed up to the saw by hand lever.

Tools for Steam Hammer Work, Fig. 343.—These generally

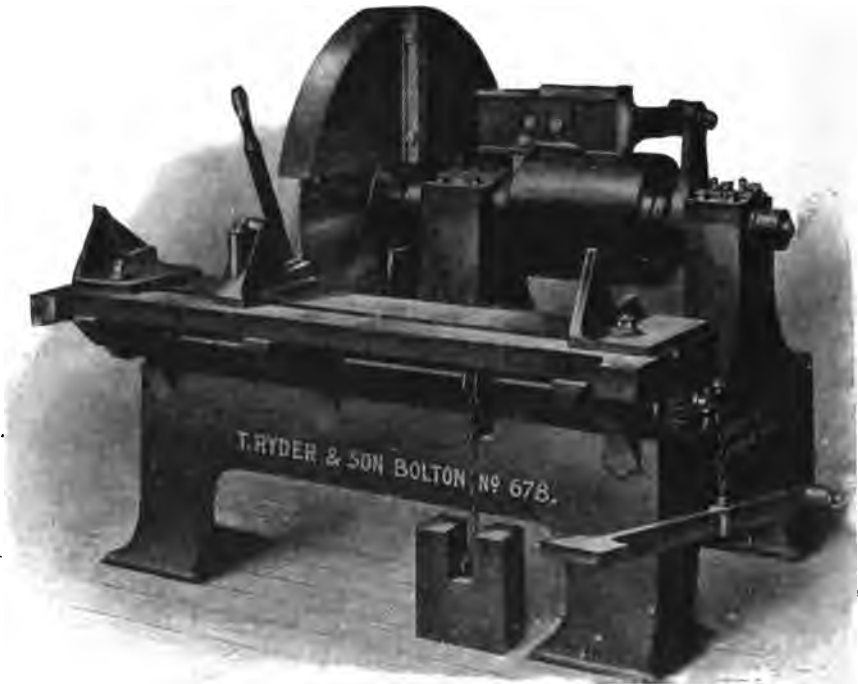

FIG. 342.—Hot Saw for Smithy.

resemble the tools used for hand work, but must be more accurately made and fitted, as they are not only intended for heavier work, but have to withstand considerably more jarring. *Tongs* must have jaws of the same shape as the work they have to hold, and must grip the same on all sides. Hence flat jaw tongs cannot be used, as they would twist on the work and ultimately slip off sideways. The correct shape for heavy work is shown at (a). The *Hammer Chisel* is made of tool steel with a mild steel handle welded on, and should be

shaped as (b). A certain amount of spring should be given to the handle by thinning out near the cutter, which might other-

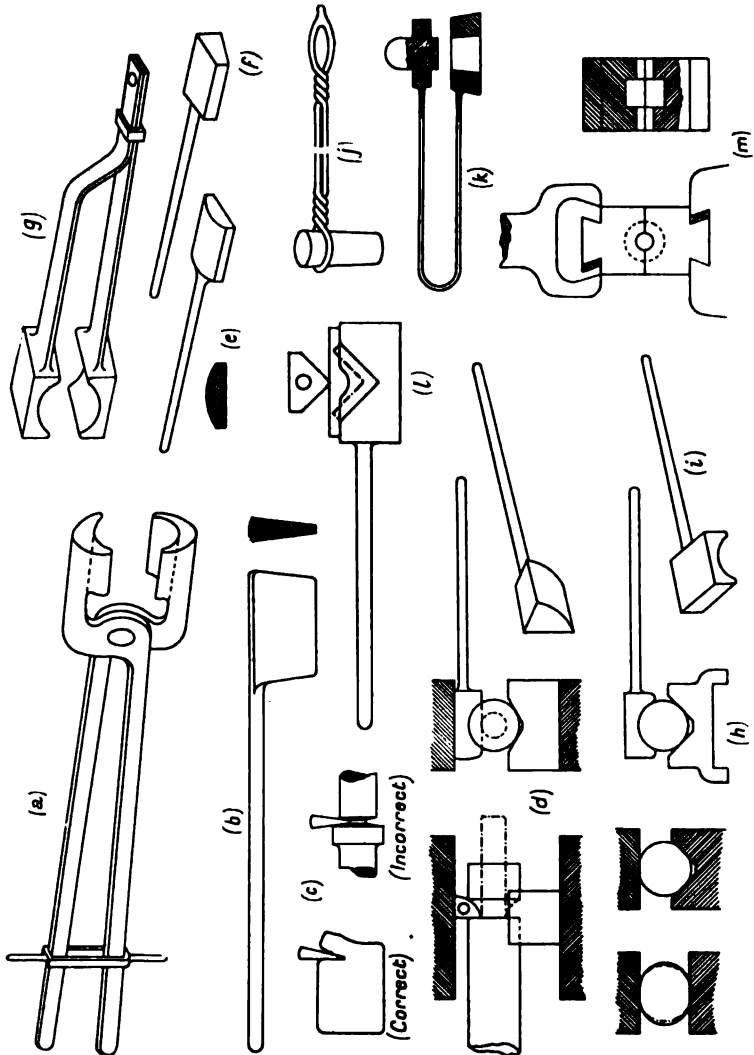

FIG. 343.—Tools for Steam Hammer Work.

wise be broken off. The edge of the chisel must be square, as seen in the section, and should never be sharp either on one or both sides. The method of using is shown at (c). Chisels are made of various shapes for special work, and a useful

modification is the shouldering or "breaking down" tool, for commencing drawing down operations, as at (d). For drawing down taper, the *fullering tool* shown at (e) is used, and for shouldering work, or for reaching parts below the upper surface, various *sets*, (f) both parallel and taper, are required. *Swages* for the smaller sizes are made with a spring handle, and are known as clapper swages, as at (g), the larger sizes being preferably separate as top and bottom tools (h), either of which may have a handle for holding up, or the bottom block may be arranged to slide on and off the anvil pallett without being held when in use. Fig. (i) shows a *single top swage* used in combina-

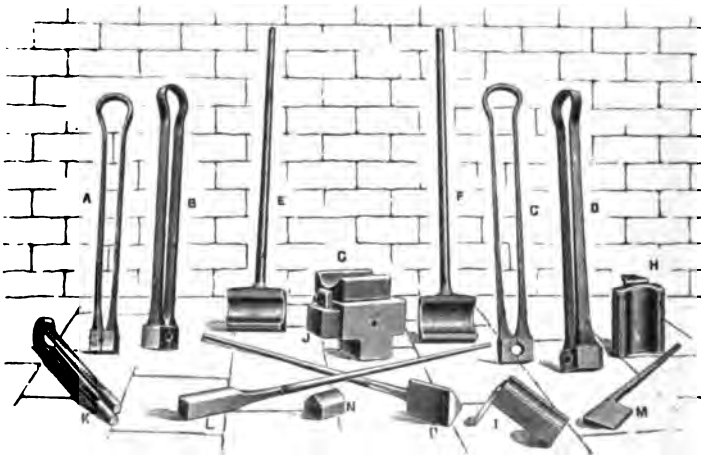

FIG. 344.—Outfit of Tools for 10-cwt. Steam Hammer.

tion with a *V block* for finishing work. *Hammer Punches* are simply plain tapering pins of tool steel, as short and thick as possible, having a groove near the upper end round which a handle of $\frac{5}{16}$ -inch round iron is twisted (j), or may be made in springy form, (k). *Circular cutters or ferrules*, which resemble annular punches, are used to form bosses on flat pieces.

An outfit of tools as recommended by Messrs. B. and S. Massey, of Manchester, for use with a 10-cwt. steam, or pneumatic power hammer, is shown in Fig. 344, in which A, B, C, and D, are plain spring swages for round iron or steel; E and F are top, and G, H, and I, bottom swages, used in pairs; J is a special anvil pallett, for holding single bottom swage in position, a ring

surrounding the swage being dropped over the projection on the pallett; K are spring necking tools; L are nobblers or flattening tools; M is a hot cutter or knife; N is a cold cutter; and O is a V-tool for shouldering.

Much use is made of *Blocks* for bending, as at (l), Fig. 343, both for straight and curved work, especially where a number of pieces of the same shape are required. Such blocks may be made of good ordinary cast iron, without being machined, and the handles may be of $\frac{3}{4}$ -inch or $\frac{5}{8}$ -inch round iron screwed in. An extension of this principle leads to what is known as *drop-forging* or *stamping*, a process much used for producing in large quantities parts of small arms, sewing machines, bicycles, engineers' tools, etc., which must necessarily be extremely accurate as regards both size and shape. Drop forgings are made between dies, Fig. 343 (m), one of which is carried by the tup, the other being secured to a very massive anvil block of a special hammer (see Figs. 320, 321, 323, and 341). The dies are made of tool steel cut out of the solid and hardened, so that when placed together, a cavity is left having the exact shape of the article to be produced. Although the first cost of "sinking" dies may be considerable, the method is found to be extremely economical where large quantities are required.

CHAPTER XXXII.

CLASSIFICATION OF OPERATIONS IN FORGING.

Work performed by the smith may be said to consist of a combination of two or more of the following simple operations: (1) Upsetting or "jumping up," (2) Drawing down, (3) Setting down, (4) Cutting out, (5) Bending, (6) Punching and drifting, (7) Welding or "shutting," and (8) Stamping. All these operations are carried out with the metal in a heated condition, which must be maintained by taking a fresh "heat" when the work shows signs of getting cold. The proper temperature for forging iron is that known as a "bright red" heat, and by taking the work from the fire from time to time when heating is going on, this may be recognised by the eye with a little practice. Metal should never be worked at a "blue" heat, or about 400° to 550° F., which is not visible in the dark, as at this temperature a peculiar brittle condition seems to be induced.

Upsetting is the operation of swelling or increasing the thickness of a piece, its length being at the same time reduced. If a short piece be uniformly heated, and struck in the direction of its length upon the face of the anvil, or if heavy enough, be allowed to fall upon a thick cast iron plate set in the floor for the purpose, or if it be placed vertically on the anvil, and struck on its upper end, it will become thicker in the heated, and therefore softer, portion and assume the shape shown in Fig. 345. If the piece is to be upset throughout its length, it must be uniformly heated, and heavy blows must be used, Fig. 345 (*a*). It should be noticed that if the ends are hotter than the body, or if light blows be given, the ends will be upset most, Fig. 345 (*b*). When forming a head or collar, the end only is heated, the result being as shown in Fig. 345 (*c*), and the effect may be confined to any part, Fig. 345 (*d*), by cooling the remaining portions in water if necessary. In upsetting common wrought iron, there may be some danger of the metal splitting in the direction

CLASSIFICATION OF OPERATIONS IN FORGING. 478

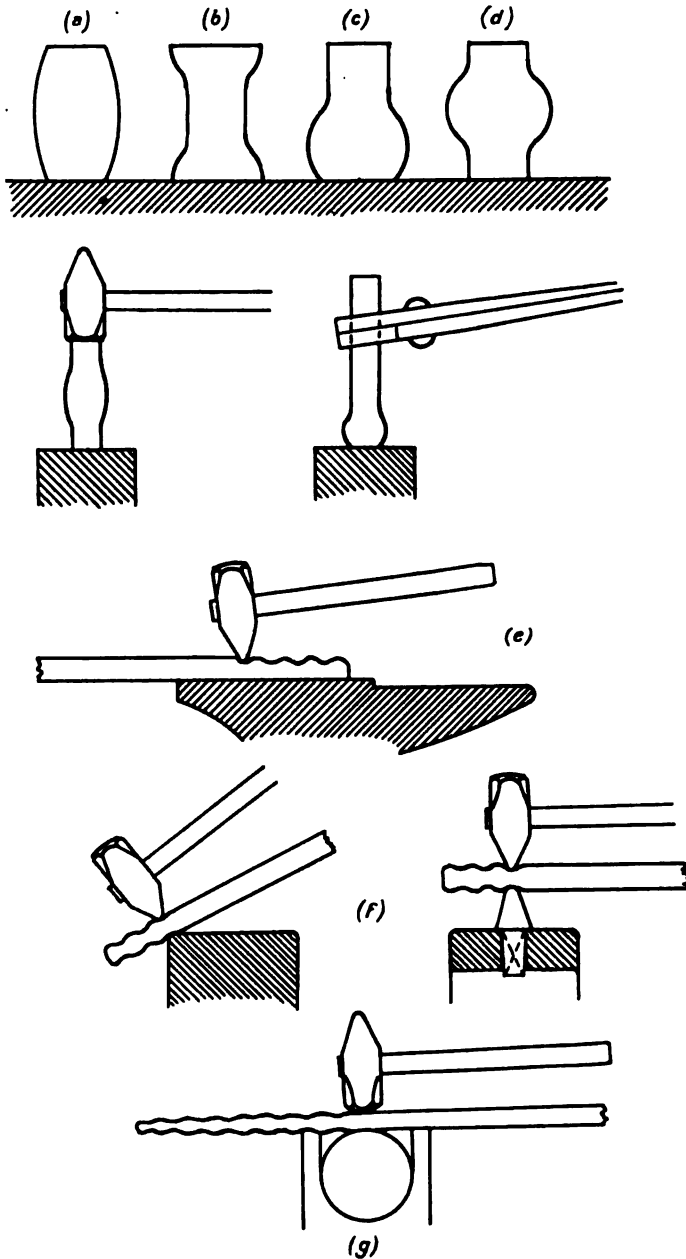

FIG. 345.—Processes in Forging—Upsetting, and drawing down.

of rolling, and as a general rule, processes in which the metal is reduced in section by compression are to be preferred.

Drawing down is the process of increasing the length of any piece and at the same time reducing either its width or thickness, or both of these dimensions, as may be required.

If the work is in the form of a flat bar, and is laid flat upon the face of the anvil, when struck with the hammer, Fig. 345 (*e*), the metal which receives the blow is pressed outwards in all directions, spreading both longitudinally and laterally, and as the result, the bar becomes longer and thinner, but at the same time wider. If, however, the breadth is to be kept the same the bar must be turned through an angle of 90° , and the operation repeated. This, it is true, will produce the desired increase in length, but will make the bar thicker, necessitating a return to the original position for thinning down again. A far more effective and quicker method of working is to draw down the bar on the edge of the anvil, Fig. 345 (*f*), or on the beak, Fig. 345 (*g*), when very little increase in width will occur, almost the whole of the work being expended in increasing the length and correspondingly reducing the thickness. When dealing with a round bar or shaft, the portion to be drawn down or pointed, is first made square, and using the method just described, is brought down to nearly the required dimension, working on each of the faces in succession. The square is then reduced to octagonal, by taking off the corners, and is finally rounded, and finished between swages. This procedure, which is invariably followed, serves to illustrate an important point which must be attended to in all drawing down operations. Care must be taken when reducing the thickness that the metal is not driven outwards from the centre to such an extent as to cause a crack or split, which, although it might be covered up and enclosed during subsequent operations, would still remain as a source of weakness. It will be seen, too, that in this respect forging by pressure possesses a great advantage over the hammer, especially for large work.

Setting down may be regarded as a local reduction in thickness effected by means of the set hammer or set, aided by a previous application of the fuller. Where a square corner is left in forming shoulders, a severance of the fibres of the material may result, introducing a tendency to start a fracture, which should be avoided if possible.

Cutting out is performed by chisels and gouges, portions of the work being cut away completely in trimming to shape, or in some cases a split may be made and opened out, or the ends bent to shape required. This method is particularly suitable for thin work where welding would be difficult. With iron, a hole must first be punched through the bar to terminate the cut, and avoid the tendency to split along the direction of the fibre.

Bending is one of the most important and frequently used

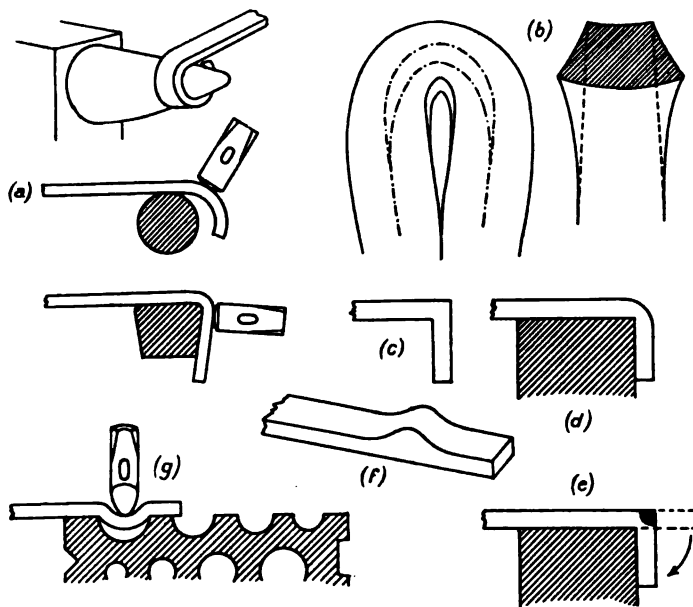

FIG. 346.—Processes in Forging—Bending.

processes in smithwork. Bends are classed either as angles or curves, and may be made, Fig. 346 (a), over the edge of the anvil on the beak or horn, or round a special block having a stem fitting in the square hole provided for bottom tools. In all cases the metal on the outer, or convex side of the bend, Fig. 346 (b), is subjected to a "drawing down" action, that on the inner or concave side being "upset." Hence a true right angle, Fig. 346 (c), cannot be formed by simple bending, which can only give the result indicated in Fig. 346 (d). The square bend must therefore be made with a "forged corner," to supply the extra

material required on the outside, which is worked up alternately with light hammers as in Fig. 346 (e); or before bending, the bar may be upset at the place where the bend is to be made, the bending being done over a V block, and the corner afterwards worked as Fig. 346 (f). Rings and eyes are bent over the beak of the anvil, Fig. 346 (a), or if of small size round a mandrel. For repetition work, special blocks or "jigs" are used, and effect a great saving of time as compared with the ordinary method of bending on the anvil, which requires subsequent setting to a template.

For making double bends, and for staples with four corners,

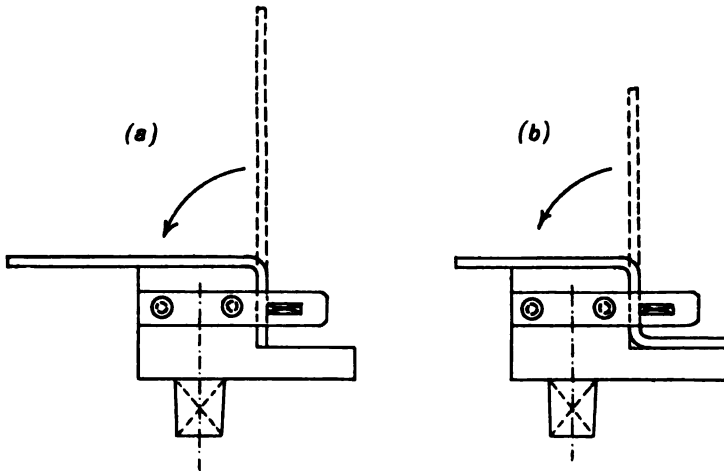

FIG. 347.—Jig for bending Staple.

simple tools can easily be contrived. A block with a stem to fit in the square hole of the anvil has a piece of flat bar secured to each side, through the projecting ends of which passes a cotter, to act as a clamp for holding the bar in position. The bar having been bent one way as at Fig. 347 (a), is withdrawn, reversed, and replaced as at (b), and the second bend made as shown by the arrow. Such blocks will answer very well if made of cast iron, even when used with the steam hammer. A lever and roller is frequently used for bending round a block, as suggested in Fig. 348 (a). A screw is used as a clamping arrangement for holding one end of the bar to be bent. This is the principle on which the bending table,

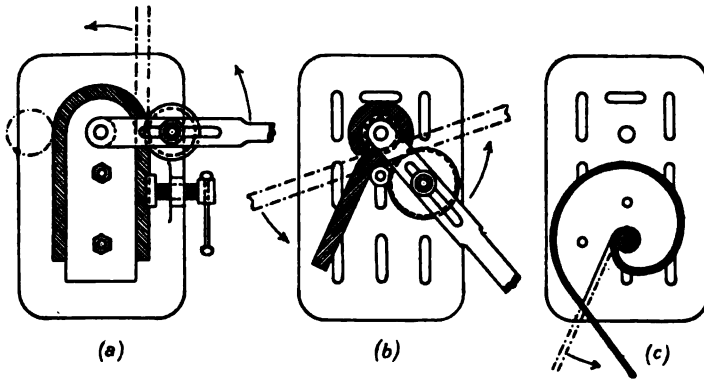

FIG. 348.—Bending Blocks.

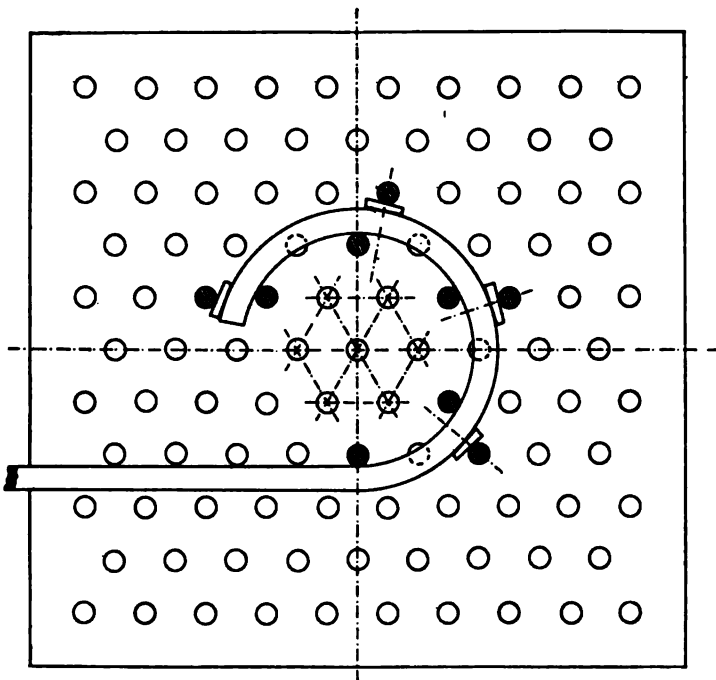

FIG. 349.—Bending Table.

Fig. 348 (c), is constructed, and it is an essential adjunct where hoops, scrolls, tyres, angle rings, etc., have to be produced. It consists of a cast iron plate of circular or rectangular form, as

may be most suitable for the purpose, with a number of slot holes somewhat resembling the face plate of a lathe. This enables bending blocks or other appliances to be fixed in position, Fig. 348 (*b*), or work may be bent against pegs inserted at intervals in the slots. These pegs are of round iron with squared ends to fit in the slots, and upon them rollers may be placed if necessary to give any required radius of bend. A very common arrangement is shown in Fig. 349.

A very neat and efficient form of *hand power Bending Tool*, developed from the appliance shown in Fig. 348, is made by the Wallace Co., of Chicago, U.S.A. In this machine, Fig. 350 (*a*), the stationary die is fixed to the frame, which is provided with a shank or lug for attachment to a bench. The stock to be bent is held between a pair of dies mounted upon the end of a lever, one of the dies being adjustable by means of setscrews and bolts to suit different thicknesses. The small tongue on the handle serves as a gauge, and may be set to any length required. Bending may be accomplished by a direct pull upon the hand lever, as in the machine shown at (*a*), or, for heavier work, an auxiliary ratchet lever may be fitted, as at (*b*), operating a pinion which gears into a toothed sector on the base of the frame. The angle through which the bar is bent is determined by a stop block, which may be clamped at any position in the circular slot seen in the upper figure. The machine shown at (*a*) will bend hot, flat stock 2 inches \times $\frac{1}{2}$ inch, and round or square bar up to 1 inch. The geared machine will take flat stock 4 inches \times $\frac{1}{2}$ inch, or its equivalent.

Punching and Drifting.—It should be noted that common iron is quite unsuitable for any work which has to be punched or drifted, as it will certainly split in the process. Even with iron of the best quality, it is advisable that any punching should be done at a welding heat, to avoid all risk of splitting. Punching is generally performed with the work flat on the anvil, the punch being driven about half way through from one side, Fig. 351 (*a*). The work is then turned over, placed upon a bolster which rests on the anvil, Fig. 351 (*b*), and the punch driven completely through from the other side, Fig. 351 (*c*). The result is a clean hole on both sides of the work, Fig. 351 (*d*), whereas, if the punch were to be driven right through from one side, a bulge or "burr" would be left, as shown in Fig. 351 (*e*). This defect

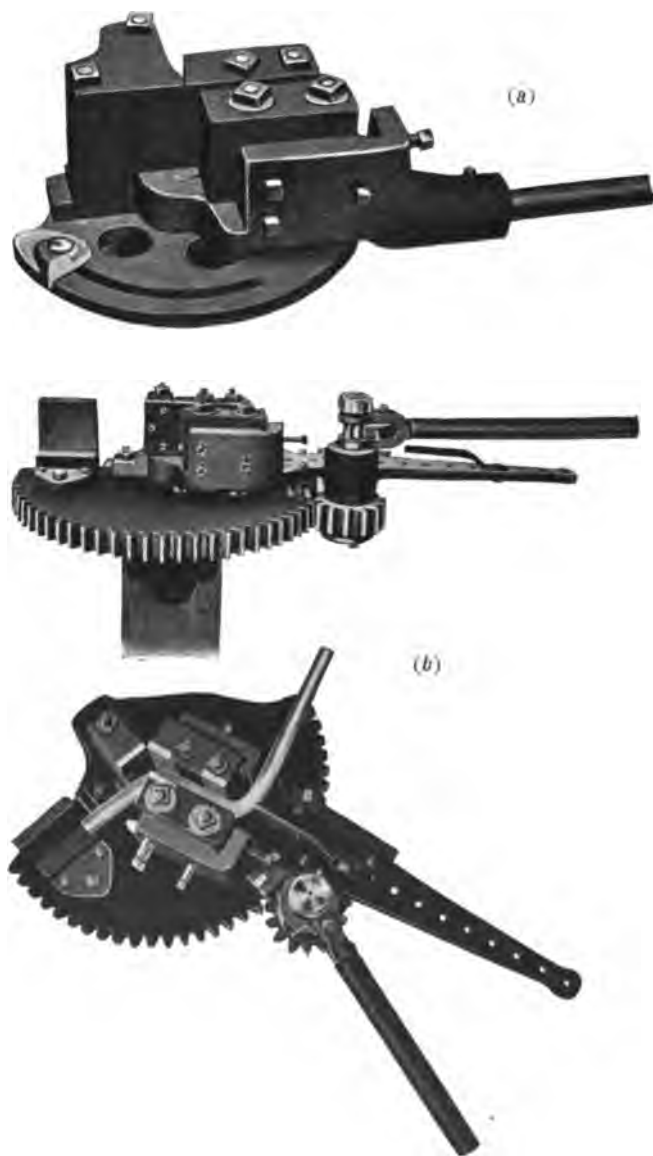

FIG. 350.—Hand Power Bending Tool.

may be obviated by using a die in conjunction with the punch, Fig. 351 (*f*). The die is made of hard steel, with a hole tapering downwards to give clearance, the diameter of the hole at the top being the same as that of the hole to be punched. The punch should also be made taper, and slightly larger at the centre, to

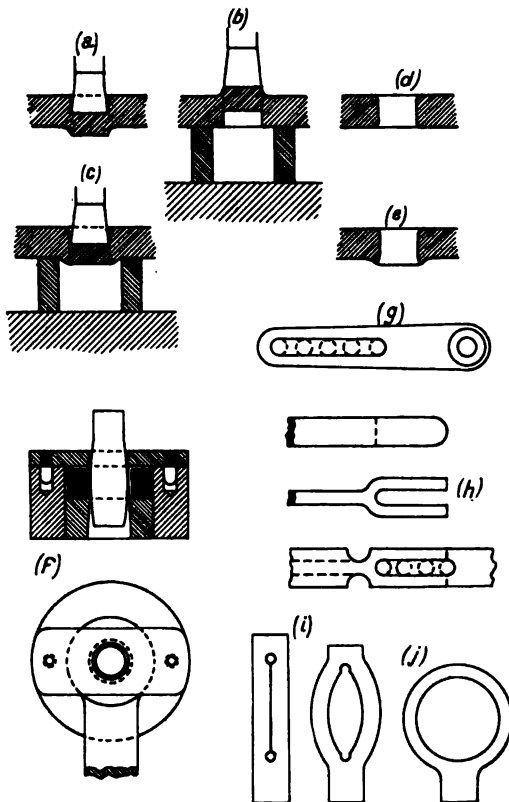

FIG. 351.—Processes in Forging—Punching and Drifting.

permit of its falling through the hole when punched. In addition to its primary purpose of producing holes of various forms, punching is often resorted to as a shaping process. For instance, a slotted lever, as in Fig. 351 (*g*), is first forged solid. A hole is then punched at each end of the slot, and in one or more intermediate positions, as shown dotted. The intervening pieces are next cut out with the chisel, and the slot finished with a drift of

the proper size and shape. Small forked ends, Fig. 351 (*h*), are readily made by punching a square bar with an elongated or slot punch, the bar being fullered or set down, and drawn out to form the rod. The bar is then cut off near the end of the slot as shown in dotted lines, and the ends of jaws trimmed to shape with the chisel. In forging a weldless ring or eye, a flat bar is punched and split, as shown in Fig. 351 (*i*). The split is opened out by driving in a tapered drift, and the sides brought to shape over the beak of the anvil, Fig. 351 (*j*).

Welding or Shutting is perhaps the principal operation performed by the smith, and constitutes the distinguishing feature connected with the manipulation of wrought iron and mild steel. Most metals when heated up to the melting point change almost at once from the solid to the liquid state. Wrought iron, however, first passes through an intermediate stage, becoming soft and pasty, in which condition if two pieces be placed together they will adhere. It is this property which, assisted by pressure, is utilised in the process of *welding*.

Welding Heat.—It is most important that the metal should be heated to the proper temperature to bring about this plastic condition. Mere hammering will not join two pieces which are insufficiently heated, but on the other hand, if overheated, the iron will be burnt, and rendered valueless. It will therefore be seen that the metal which remains pasty over a wide range of temperature is the most easily welded, and in this respect wrought iron has some advantage over mild steel. The welding temperature for wrought iron is from 1500° to 1600° F., and if this be exceeded, the metal commences to burn, throwing off white sparks resembling small stars. The welding heat for mild steel is lower, and is known practically as the point where bright red is just about to change to a white heat. The first essential to the production of a sound weld is that the surfaces in contact are perfectly clean, both mechanically and chemically. Iron at a high temperature exposed to the air at once oxidises or rusts, becoming covered with a thin film of black scale, or oxide of iron, which, together with any dirt or dust due to ashes or cinder from the fire, must be got rid of, or perfect contact will be impossible. It is therefore necessary to employ a flux which melts at the high temperature, dissolving the scale and ash to form a slag, and at the same time acting as a protective covering to prevent

further oxidation. When welding wrought iron, the smith, on withdrawing the work from the fire, sprinkles the surfaces with sand, which melts and produces a liquid slag, easily expelled by the first few blows of the hammer after the pieces have been put together. Welding should therefore commence at the centre of the joint, so that the slag may exude laterally, thus allowing clean metallic surfaces to unite outwards. The welding temperature of steel, and particularly of the harder varieties, is not high enough to melt sand, but a flux of calcined borax, or better still, a mixture of 4 parts borax, with 1 part sal-ammoniac, is found to give good results. It is sometimes stated that a flux is not absolutely necessary for wrought iron, as it may be safely heated to a temperature at which the oxide or scale becomes fluid. Common iron, too, may form a flux out of its own impurities, but in any case, a flux greatly facilitates welding.

Forms of Welded Joint.—Three distinct forms of welded joint are commonly recognised: (1) the butt-weld, Fig. 352 (a), in which the two pieces to be joined are simply butted together, the weld being between the ends and at right angles to the length of the piece; (2) the scarf or lap-weld, Fig. 352 (b), in which the ends are prepared so that they may be welded one upon the other, with the joint in an inclined direction; and (3) the V weld or splice, Fig. 352 (c), in which the ends are first brought to the shape of a fork and tongue respectively. In making a butt-weld in the ordinary manner by hand, it is not easy to ensure that the two pieces are brought together with the necessary pressure, as the blows of the hammer cannot well be delivered in a direction at right angles to the joint. Under such circumstances, the butt-weld is not regarded with favour, being neither so strong nor as reliable as the scarf-weld. The difficulty is, however, completely overcome in machine welding, whether power or electric, in which case the butt joint may prove satisfactory. A good example of a hand-power *welding machine*, made by the Nicholson Tool Company, of Newcastle-on-Tyne, is shown in Fig. 353. The work is firmly secured in a pair of vices, in such a manner that the joint to be welded rests upon the table or anvil in the centre of the machine. Each vice is carried upon a vertical rocking lever, pivoted at its lower end, and passing through a slot in the upper part of the frame. Immediately below the anvil is a shaft upon which is keyed a powerful hand

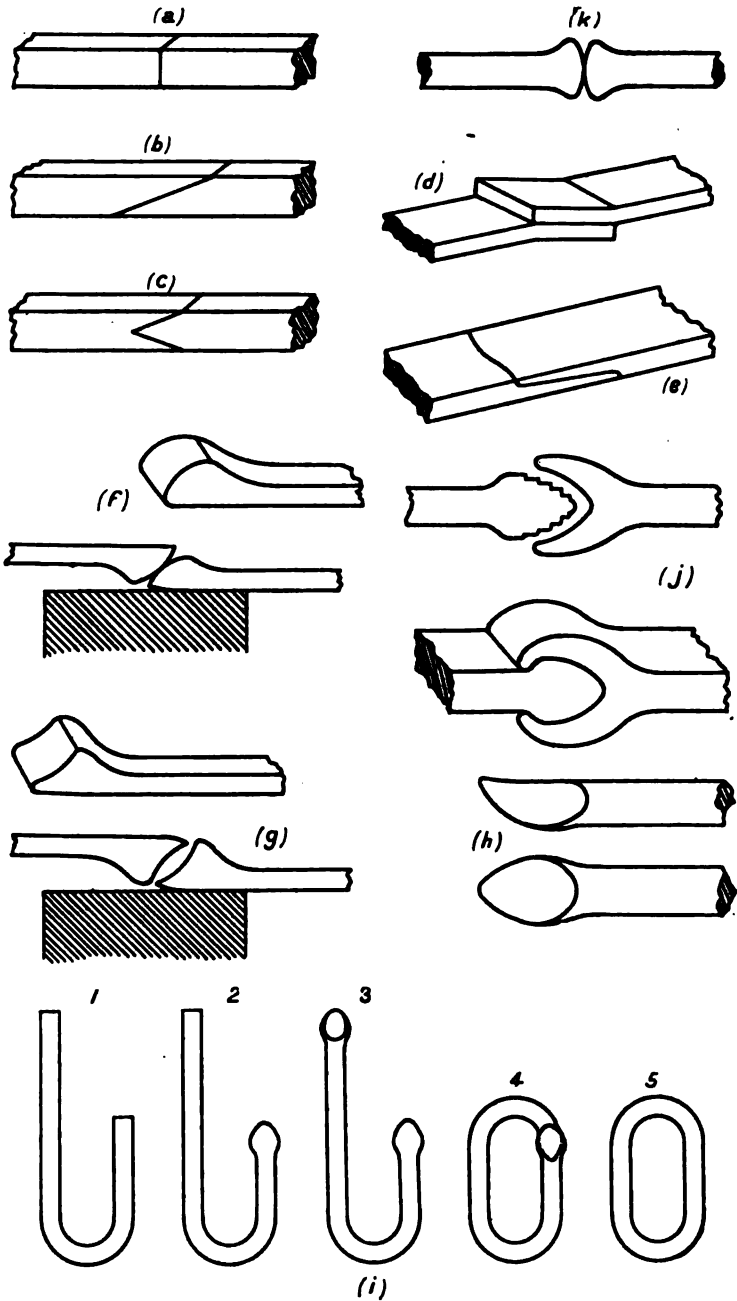

FIG. 352.—Forms of Welded Joint.

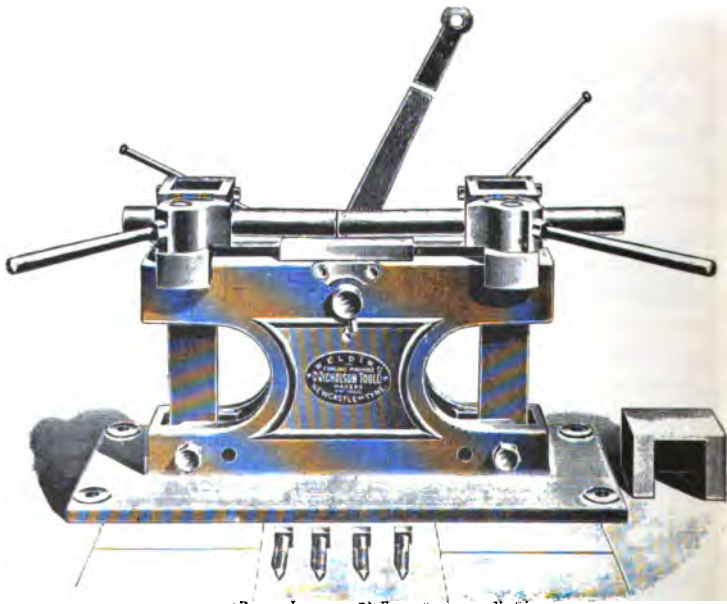
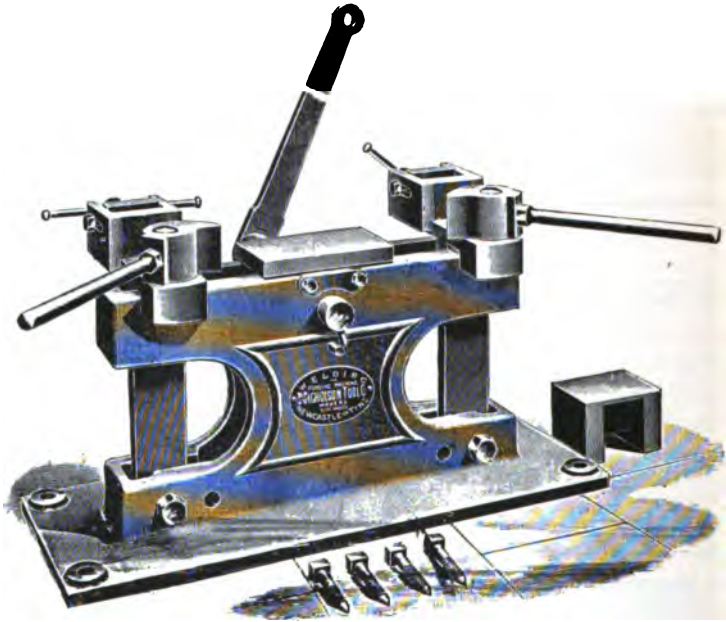

FIG. 353.—Hand-power Welding Machine.

lever and also two eccentrics, the latter placed within the frame. The eccentrics are coupled up respectively to the rocking levers on which the vices are fixed. The arrangement gives a mechanical advantage of about 200 to 1, so that, with one man on the lever, it is possible to exert a pressure of as much as 20 tons between the two bars held in the vices. The machine will weld bars and shafts up to 5 or 6 inches in diameter, without scarfing or any other preparation. The bars having been raised to a welding heat, are placed in the machine as shown in the lower figure, and are immediately gripped by the cams. Power is then applied by the lever to squeeze the bars into each other, and while the pressure is on, the outside of the weld is closed by hammering, to leave the joint smooth and uniform in thickness.

Scarfing.—The method of preparing or shaping the pieces for welding is an important matter, as it exercises considerable influence in expelling the slag when contact is made. In the *lapweld*, two pieces of flat bar, Fig. 352 (*d*), might be welded together without any preparation by merely overlapping their ends, but the joint, Fig. 352 (*e*), would be imperfect, a crack being left on either side, where the thick edge of the bar has been forged down. It is evident that the ends should be drawn out, but not too thin, as a welding heat always causes some loss due to scaling, for which allowance must be made. The ends must therefore be upset, and shaped slightly convex, Fig. 352 (*f*), so that when put together the junction takes place first at the centre, extending to the edges, and forcing out the slag in front. The special tool shown at Fig. 356 (*d*), which has a shank to fit the square hole of the anvil, is a most useful appliance for upsetting and scarfing, giving the correct form without any trouble whatever. If the scarfing is straight or slightly concave, Fig. 352 (*g*), a cavity will be formed in which the slag will be locked when the edges, which first come in contact, are welded together. In welding round bar, the same method must be followed, the scarf being shaped as shown in Fig. 352 (*h*). This is applied in chain making, and the various stages in the formation of a link will be seen from Fig. 352 (*i*). Messrs. Brown, Lenox & Co., Ltd., of Pontypridd, South Wales, who have a world-wide reputation for this class of work, have kindly supplied photographs from which Figs. 354 and 355 have been prepared. The former illustrates clearly the operation of welding in a link of a large



FIG. 354.—Welding link of Chain Cable for Super-“ Dreadnought.”

chain cable for a Super-“Dreadnought.” It is interesting to note that a Super-“Dreadnought” requires several hundred fathoms of chain cable, made up of lengths $12\frac{1}{2}$ fathoms each, connected by shackles. The links are made from rolled bars, varying from 3 to $3\frac{1}{4}$ inches in diameter, which are cut to length, scarfed for welding, and bent into shape by special machinery. It is then that the human element comes in. It is a curious fact that although machinery has been tried, hand-made chain, especially of the largest size, is still supreme. In the upper view, the

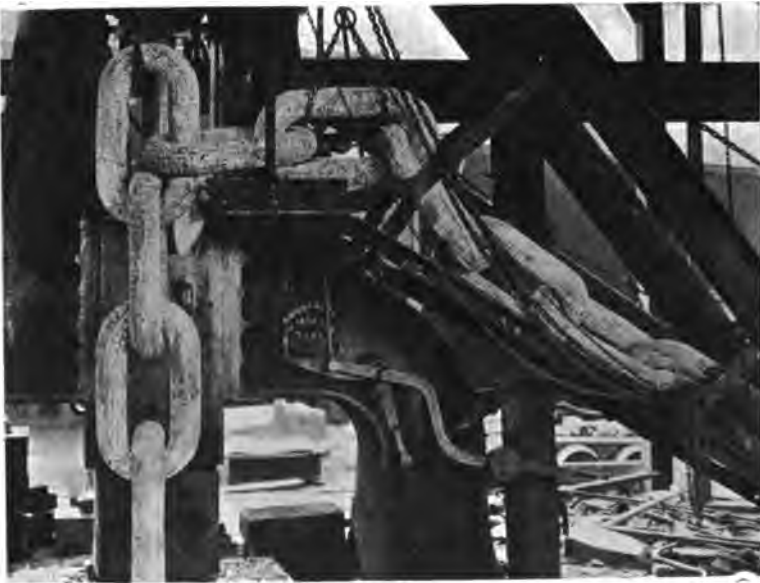

FIG. 355.—Welding Chain under Steam Hammer.

chain-maker is seen holding the tongs and swage, and the sledge is swung by two men. In addition to the care which must be taken to ensure efficient welding, each link must be made exactly to gauge, as the chain has to work over a capstan. Men able to weld efficiently such large chains are few in number, and seem to be possessed of an instinct which is often transmitted from father to son. The lower figure shows the link completed. To test the reliability of each $12\frac{1}{2}$ fathom length, three links are selected and cut off for testing to destruction by tensile stress. If these three links do not withstand the specified load, the whole length

is rejected; but if the test is satisfactory, the whole length is then subjected to a proof stress of double the working load.

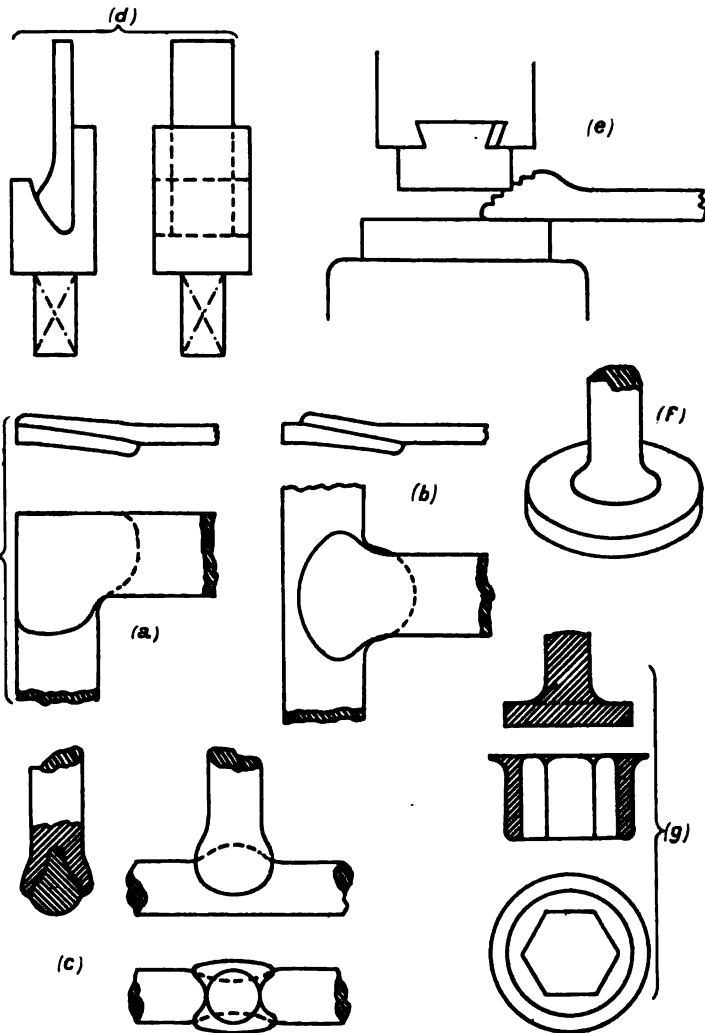

FIG. 356.—Corner and T Welds, Stud Weld, etc.

Fig. 355 shows the method of welding chain under the steam hammer, the dies for the purpose, and the arrangement for supporting the chain as it is produced, being clearly seen.

CLASSIFICATION OF OPERATIONS IN FORGING. 489

Corner and T welds are made in the manner indicated in Fig. 356, the scarfing being shown at (a), (b), and (c).

Split, Fork, or V Weld, or Splice.—For heavy work, the split or fork, Fig. 351 (j), is regarded as the most secure form of weld, not only on account of the greater extent of surface at the joint, but also because the hook-like ends of the split are driven down over the bulbed end of the solid piece. The scarfing on the sides of the latter should be left rough, in little steps, which is easily done under the steam hammer by drawing the bar away slightly after each blow, Fig. 356 (e). Long connecting rods for stationary steam engines are usually welded up in this way, and it is also the best method to employ when welding tool steel to wrought iron or mild steel.

Butt or "Jump" Weld.—For some purposes, the ends of the two pieces are simply butted together, the weld being square across at the joint, Fig. 352 (k). The ends are first upset and slightly rounded, so that the slag may be properly expelled from the joint. The welding is effected by striking the ends of the pieces, if possible, or by pressing them together in a welding machine. In some cases, the pieces need not be removed from the fire, the end of one piece being "held up" against a sledge while the other is struck with the hammer. After welding, the upset portion is reduced to size and finished under the hammer. Wrought iron gas pipe is made with a butt weld, as it is cheaper, and no great strength is required, but tubes for water or steam, having to carry considerable pressure, must be lap-welded at the longitudinal joint. Butt-welded pipes cannot be used for bending, as they are particularly liable to split when so treated.

Strength of Welded Joints.—A butt-weld is neither so strong nor so reliable as a lap-weld, and it is found on testing that a butt-weld invariably breaks at the joint, the fracture being largely crystalline. A good lap-weld, on the other hand, may possibly be as strong as the solid bar, although its elongation and contraction of area will always be less. This is explained by the fact that the mechanical work put upon the material in making the weld tends to raise its ultimate strength at the expense of its ductility. But even when the same care has been exercised, and under precisely similar conditions of working, the strength of welded joints is found to vary considerably, and taking the

average, it is not safe to assume that the strength of a weld will exceed 75 per cent. of the strength of the solid bar.

Stud Weld.—A modification of the butt-weld is sometimes applied in making handrail stanchions or pillars, which have to be provided with a flat foot for bolting to a platform or floor. It is difficult to ensure that the weld in this case shall be perfect, and it should, in fact, be avoided in high-class work. The end of the pillar should be upset, Fig. 356 (*f*), so as to resemble a mushroom head or flange of as large a diameter as possible. In the centre of the foot, an indentation is made with a "bob punch," a tool well rounded at the end. Both pieces are then raised to a welding heat, the foot laid on the anvil, and the rounded end of the pillar

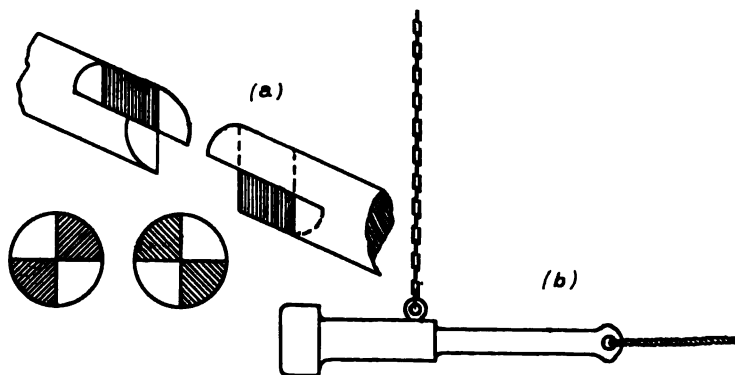

FIG. 357.—Shaft Weld and use of pendulum or tup.

driven well into the hollow by a few blows of the hammer, and the weld completed by working round the flange with the fuller or set hammer. In making box-spanners for large nuts, this method of welding is also employed. The key is forged as a thick tube, Fig. 356 (*g*), the interior being made hexagonal by means of a drift of the proper size. The end of the tube is then scarfed as shown, and a flange of the same size as the tube having been forged on the shank, the two are jump-welded together, as suggested in the sketch, first using the fuller on the top of the flange, and afterwards working down the scarf in the bottom swage.

Shaft Weld.—For making a weld in 3 or 4 inch shafting, or for parts subjected to torsional stress, it is sometimes considered

CLASSIFICATION OF OPERATIONS IN FORGING. 491

desirable to assist the weld by combining with it the effect of interlocking the ends on the principle of the claw clutch. The end of each shaft is heated, and cut along two diameters at right angles to a depth of $1\frac{1}{2}$ or 2 inches. Two opposite portions are then removed from the end in each case, leaving the shafts ready to be fitted together, Fig. 357 (a). When this has been done, they are raised to a welding heat, and welded together in the fire. For this purpose, a tup or pendulum is swung against the end of one shaft, a heavy weight being suspended against the end of the other. The tup is suspended at the proper height by a chain, and a rope is attached to it, so that it may be swung by several men, Fig. 357 (b).

CHAPTER XXXIII.

THE SMITHY,—SIMPLE EXAMPLES OF FORGING.

It is possible to produce pieces of comparatively complicated shape by a combination of the primary operations just described. It should, however, be borne in mind that at best forging is necessarily an expensive process, and it is therefore desirable that the designer should restrict himself to the simplest possible forms, and avail himself of well-known methods of working, so that the cost of production may be brought down to a minimum. In some directions, attempts have been made to dispense with smithwork altogether, and special automatic machinery is now largely employed in producing screws, studs, collared-ended pieces, and similar parts which are turned down from the solid bar at less than the cost of the forgings which would first have to be made in the ordinary way of working.

Although, of course, it will not pay to make bolts by hand, the process of forging a head on the end of a round shank must be regarded as a normal or standard operation in constant requisition, involved in the production of many parts, and by no means confined to the making of bolts. In the same way, it will be found that the every-day work of the smith includes many articles, portions of which are forged in precisely the same manner as the simple examples which follow.

(1) **Collared End or Bolt Head.**—A head may be forged in two ways, either by upsetting, or by welding. For bars of small diameter the first method is generally used, whilst for larger sizes a ring is welded on. To *upset the head* the bar is heated at one end, and is jumped up by one or two smart blows of the hammer, Fig. 358 (c). It is next dropped through a heading tool, placed directly over the square hole in the anvil, and the head hammered down as in Fig. 358 (d). The piece is then knocked out, and the head forged to shape, round or square as the case may be, on the anvil, after which, if hexagonal, a second heat is taken, the head finished in the “nut swage,”

Fig. 358 (e), and finally chamfered by the cupping tool, Fig. 358 (f), using the heading tool as support. To make a *welded head* a ring is first bent on the end of a round bar of the proper section, the diameter of the inside of the ring being the same as that of the stem. The ends of the ring are scarfed ready for

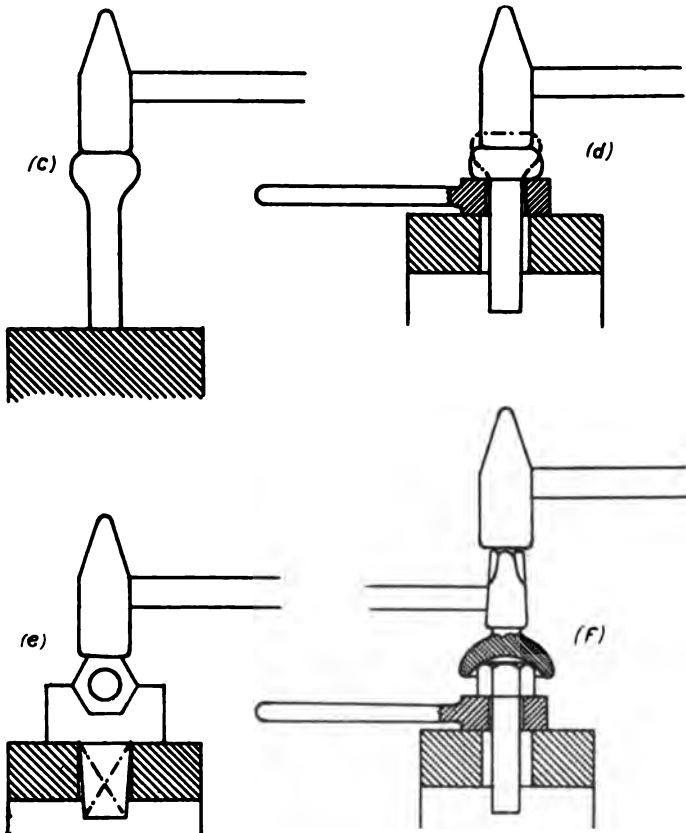

FIG. 358.—Forging a bolt head.

welding, and it is then closed upon the stem, which is allowed to project through slightly, as in Fig. 359 (a). The two are raised to a welding heat, the collar is welded on, and may be forged roughly square in the first instance to ensure a sound weld. The bolt is then dropped into a heading tool, and the projecting end rivetted over, after which the head is brought to shape in a swage, as in the case of an upset head.

(2) **Cock Piece.**—A small forging to serve as a bearing for a spindle is shown in the sketch, Fig. 359 (b). This would be

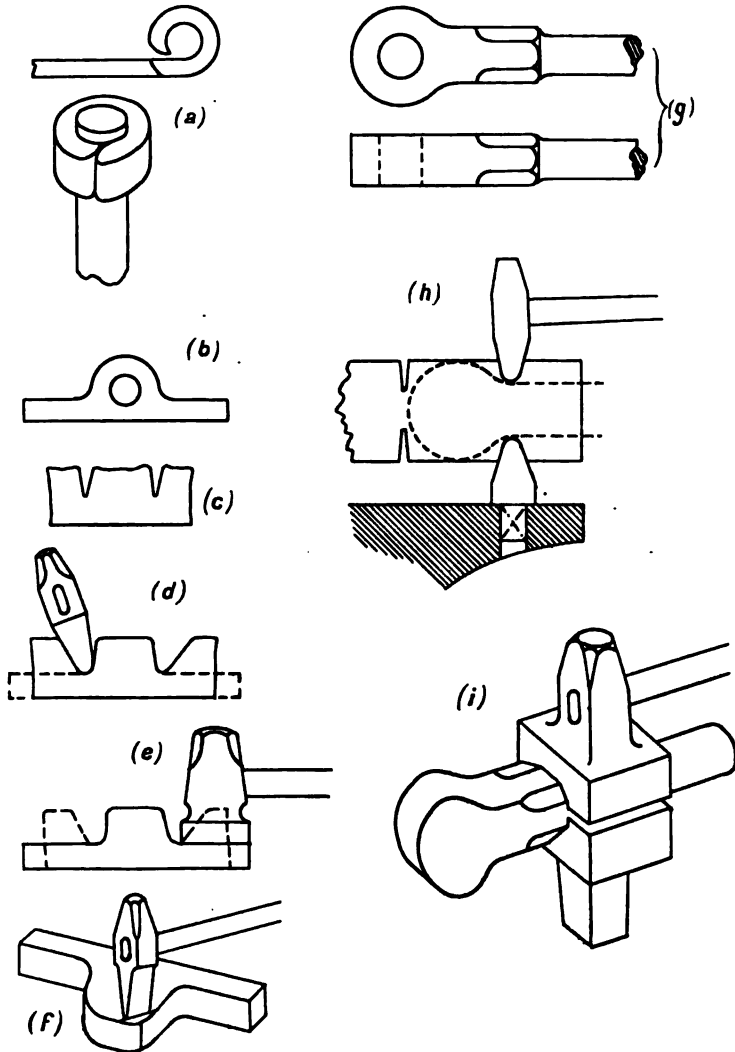

FIG. 359.—Simple Examples of Forging.

made from bar somewhat wider than the widest part, and as thick as the thickest part of the forging. To begin with two cuts are made with the chisel at a distance apart about equal to the

diameter of the boss, Fig. 359 (c), and are opened out by driving in a fuller, as in Fig. 359 (d). The ends are next set down with the set hammer, Fig. 359 (e), and after taking a second heat are forged out square, the corners of the boss cut off with the chisel, Fig. 359 (f), and the hole punched.

(3) **Eye End for Tie Rod.**—Fig. 359 (g), is dealt with in a very similar manner, the end being forged separately, and afterwards

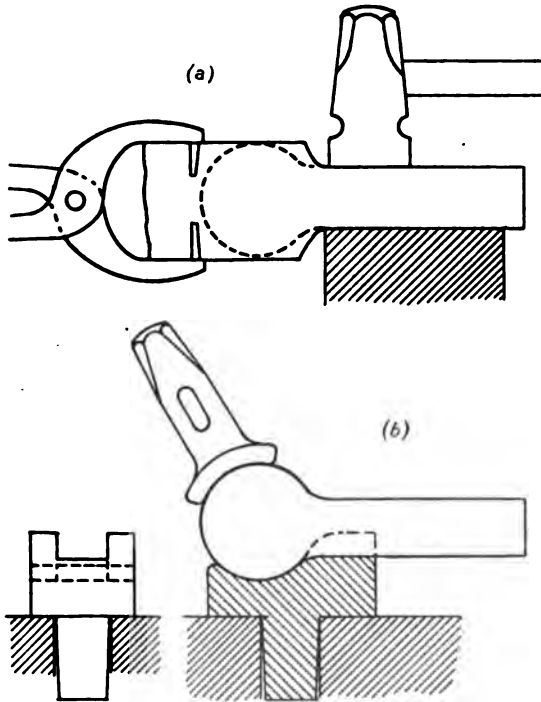

FIG. 360.—Forging Eye End for Tie Rod.

welded on the rod. A lump of proper size is fullered on both sides, Fig. 359 (h), set down as in Fig. 360 (a), and the shank forged down square to size on the anvil. The end is then cut off, the eye trimmed with the hot chisel, and finished round with side swages, Fig. 360 (b), the shank flattened and the corners fullered. It is then re-heated to swage down the octagonal portion, Fig. 359 (i), and the round part at the end of the same size as the tie rod.

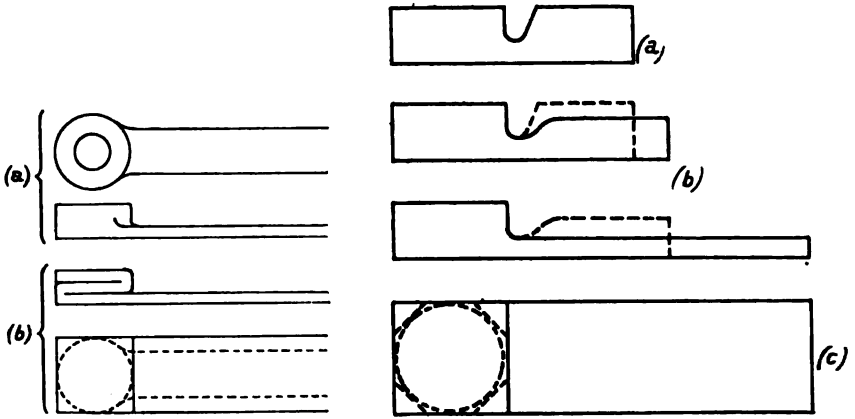

FIG. 361.—Forging a Boss on end of Lever.

FIG. 362.—Forging Boss by Drawing Down.

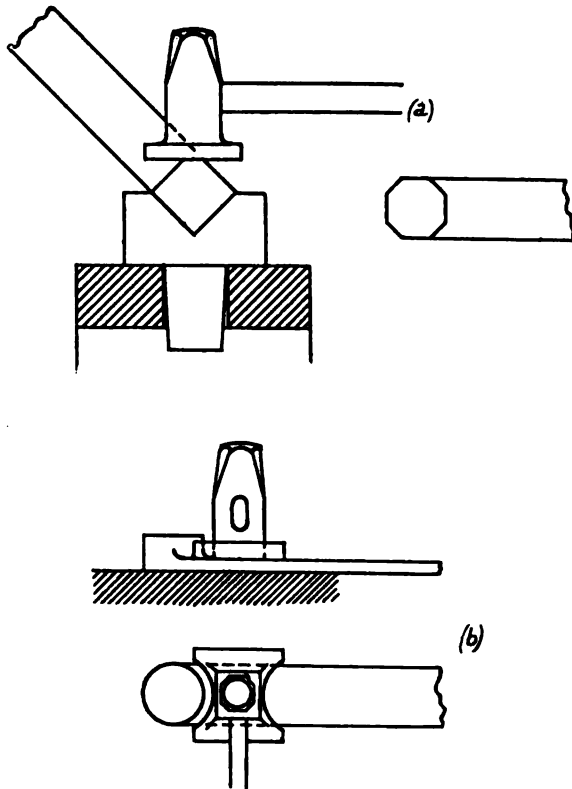

FIG. 363.—Forging Boss by Hand.

(4) **Forging a Boss.**—Links and levers for engine and machine work have usually to be made with bosses at the ends, Fig. 361 (a).

A boss may be welded on or may be formed out of solid by drawing down, Fig. 362. In either case a square lump is first made on a flat bar, the subsequent process of rounding and finishing the boss being the same whichever method is adopted. For thin bosses or faces, washers or collars of the proper size could be made and welded on the bar in the usual way. Deeper bosses may be formed by folding over the end of the bar to the required thickness and welding the whole together, Fig. 361 (b). Where bosses are made of standard sizes, cast iron blocks, similar to those shown in Fig. 379 (a), may be provided, in which the boss may be stamped under the steam hammer from the lump obtained as above, the end being first roughly cut round. If the work is done by hand, the boss must be worked up with the set hammer, first forging off the corners, Fig. 363 (a), and afterwards rounding up with a side swage which is slotted for the flat part of the link, Fig. 360 (b). For finishing the flat part, a set hammer rounded out at the sides, Fig. 363 (b), to fit close

up to the boss is a great convenience. According to the second method of working in which the lever is forged out of solid, a lump must be taken large enough to make the boss without upsetting. The boss may be stamped out under the steam

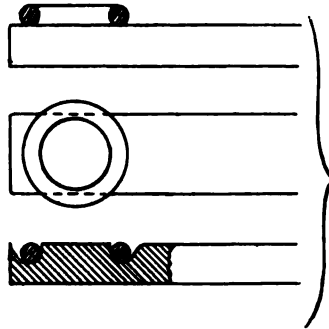

FIG. 364.—Stamping out Boss under Steam Hammer.

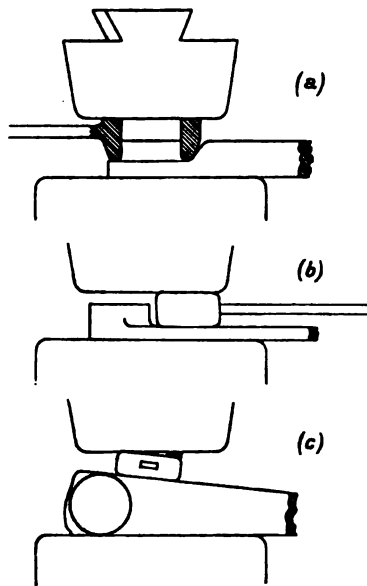

FIG. 365.—Forging Boss under Steam Hammer.

hammer either with a steel ring, Fig. 364, or by means of an annular cutter or ferrule, Fig. 365 (a). The flat part is then forged out under the flat palletts, using sets, if necessary, Fig. 365 (b) and (c). The square corners left at the end are next cut off with the chisel, and the boss finished with side swages as before. To

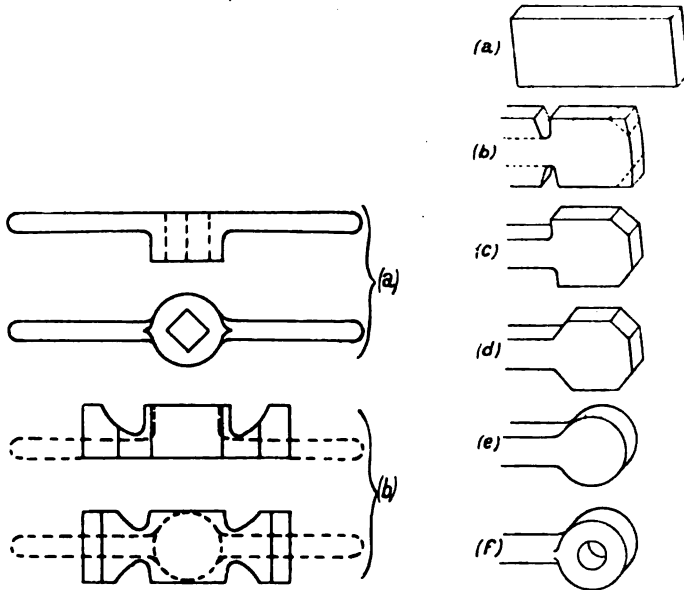

FIG. 366.—Forging a Lever Handle, or Tap Wrench.

FIG. 367.—Forging a large Eye End.

make a boss out of solid by hand, a portion is left of full thickness at the end by driving in a fuller as in 362 (a), the remaining part being flatted down and drawn out to proper size, proceeding as shown at (b). The square end thus obtained as at (c) is subsequently reduced to circular form exactly as already described. A round lever or handle with a boss in the centre, Fig. 366 (a), as used for tap wrenches, etc., is produced in the same manner. A square piece large enough to make the boss is fullered as shown in elevation and plan at Fig. 366 (b), the ends forged out, and the boss rounded up as before.

The method of forging a large Eye End under the steam hammer is illustrated in Fig. 367. Commencing with a solid rectangular block or lump of suitable size (a), top and bottom

fullers are driven in from opposite edges at such a distance from one end as to leave sufficient material for producing the eye (b), and the portion on the left in the figure is drawn down to form the body of the rod or link. The outer and inner corners as at (c) and (d) are next cut off, bringing the end to an approximately octagonal form, which is reduced still further to the required circular shape under the hammer (e). If required of cylindrical form, the body of the rod is then rounded and finished to size in swages, and finally the hole is punched as at (f).

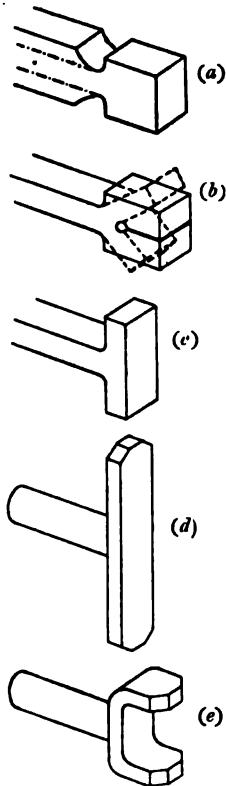

FIG. 368.—Stages in Forging a T End.

the rod, two deep grooves are made with top and bottom fullers, as in Fig. 368 (a). The body of the rod is then drawn out to proper size as shown by dotted lines, and the lump left on the end is punched and split as at (b). After opening out the split as shown in (b), the ends are drawn down to proper size over the edge of the anvil with the set hammer or flatter, and are bent back to the required form as at (c), any unevenness which may

(5) Forging a T End.—Being easily

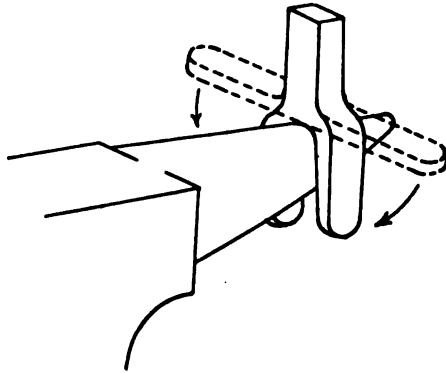

FIG. 369.—Forging a forked end from T.

forged and machined, the T end forms an important element in machine construction, occurring frequently in engine connecting and eccentric rods, etc. Commencing with a lump about twice as wide as the thickness of the T end, and somewhat thicker than the diameter or thickness of

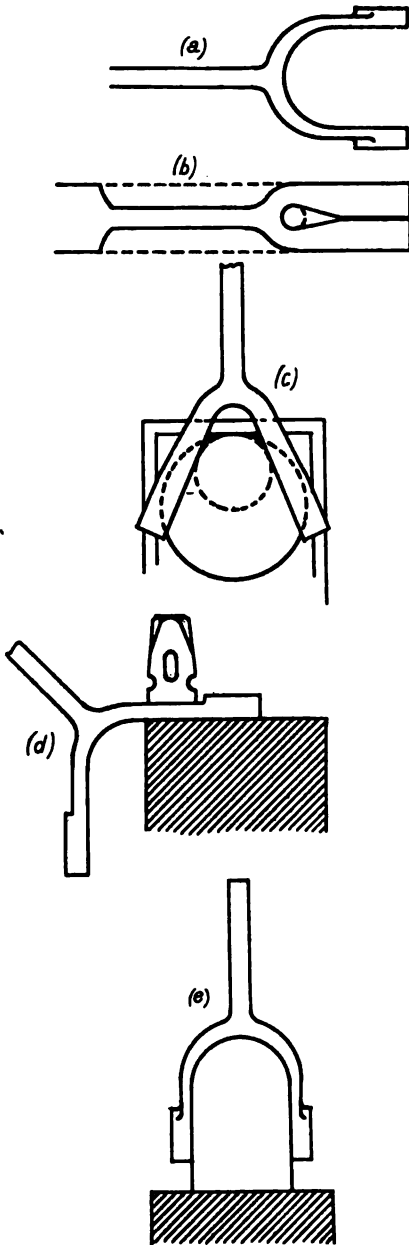

FIG. 370.—Forging a Forked End.

be left being pared off with the chisel. The junction with the body of the rod must be rounded out with a fuller as in (d).

(6) **Forging a Forked End.**

This may be done in several ways, depending upon the nature of the work for which the forging is required. A T end may first be formed, as explained above, Fig. 368 (e), and after being forged out straight, the ends may be bent round the beak of the anvil as indicated in Fig. 369, or they may be closed down over a block of the required shape as shown in Fig. 370 (e). This method, where circumstances will permit of its adoption, is probably the best which can be employed. A boss may be required on each jaw of the fork, Fig. 370 (a), in which case sufficient material must be left when the lump is split down the centre, Fig. 370 (b). The corner left by the punch should be cut away, and the split opened by driving in a fuller until the ends will pass over the beak of the anvil. The jaws are then opened out straight by using a fuller on the shoulders, Fig. 370 (c), and the bosses formed as shown in Fig. 370 (d). The jaws

are finally set on a block of the proper size and shape as above, Fig. 370 (e). The forging for a small eccentric rod is sometimes made by welding a flat foot upon the flat rod, Fig. 371, but this

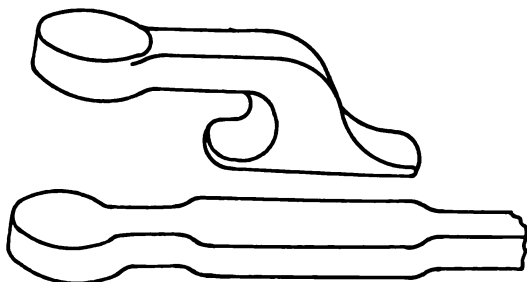

FIG. 371.—Welding Forked End.

cannot be regarded as satisfactory practice, the weld being an awkward one to make properly. All such details should be forged out of solid, and, if necessary, welded on to the stem

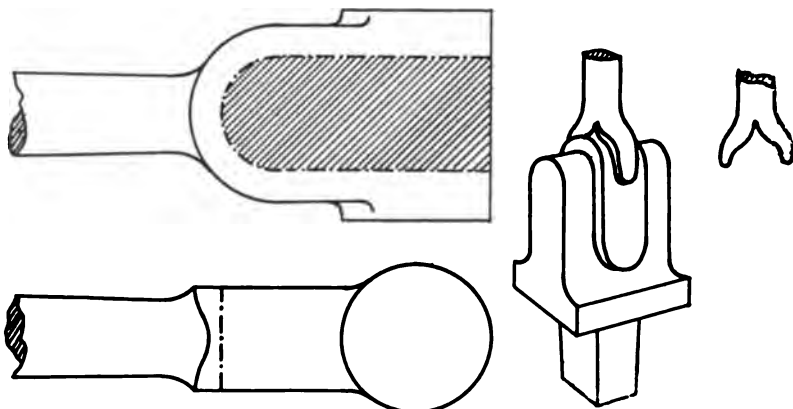

FIG. 372.—Forked End cut out of Solid.

FIG. 373.—Welding Forked End.

afterwards, nothing in the nature of a butt-weld being permitted in engine work. A fork-ended connecting rod is forged solid as in Fig. 372, the gap between the jaws, shown section lined, being cut out in machining. Although the forging is much simplified, to produce a fork in this way is a costly matter, on account of

the expense of machining. A forked end is sometimes made by welding the fork on the rod over a tool in the anvil, in the manner shown in Fig. 373.

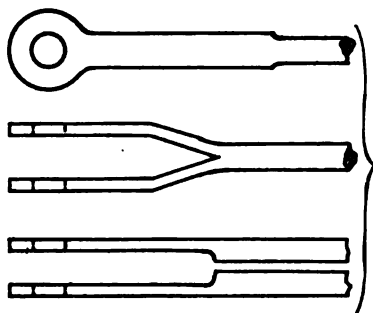

FIG. 374.—Forging Forked End for Structural Work.

This is, however, very objectionable, and should not be permitted in high class work. The form of forked end used for structural steel work, Fig. 374, is made by forging the two sides separately and then welding them together, the fork being finally set on a block. The forked end is subsequently welded on the tie rod for which it is intended.

(7) **Forging a Hook.**—Two forms of hook are in common use, viz., the chain hook which is forged with an eye, Fig. 375,

and the crane or hoisting hook, which has a screwed shank, Fig. 376 (c), for attachment to the block of a crane. In the first case, the eye should be forged to begin with, by upsetting the end of a bar of a section sufficient to form the body of the hook, fullering a groove to give the neck, and rounding to shape on the edge of the anvil. The hole is then punched, drifted out to size, and the corners rounded out over the beak of the anvil. The eye may also be formed by welding as at Fig. 375 (a), but this is very objectionable. Whilst still straight, the body is next forged to correct shape, taking measurements of the length by means of a piece of wire, Fig. 376 (a).

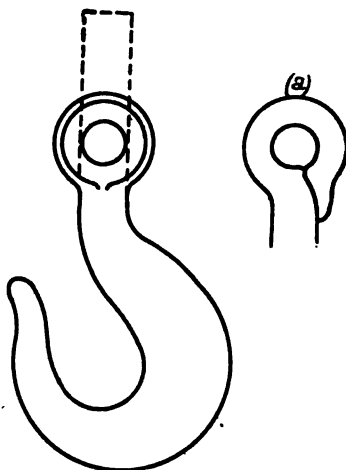

FIG. 375.—Forging a Chain Hook.

The neck is then heated, and holding the eye in a vice, is bent as nearly as possible to the required curve by means of a pipe placed over the end to act as a lever. The body is next bent over a large swage block, and after

“setting down” in a special tool, Fig. 376 (b), is finished over the beak of the anvil, or on a saddle-shaped block of the proper form,

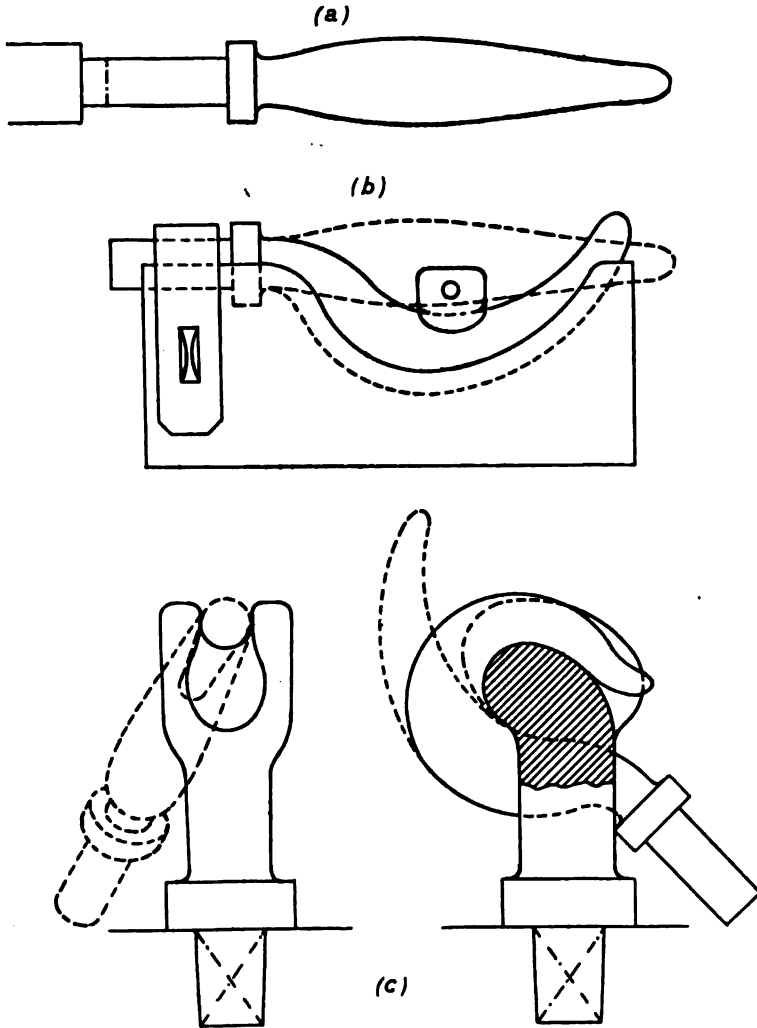

FIG. 376.—Forging a Crane Hook.

which fits in the square hole of the anvil, Fig. 376 (c). For hooks forged in the ordinary way, best Yorkshire iron is undoubtedly the best material, but large quantities of soft steel crane hooks are



FIG. 377.—Crane Hooks and Results of Tests.

now made by drop forging, and have proved satisfactory in every way. A good crane hook should carry four or five times the working load without permanent set, and should bear straightening out cold in the testing machine without showing any sign of fracture, Fig. 377.

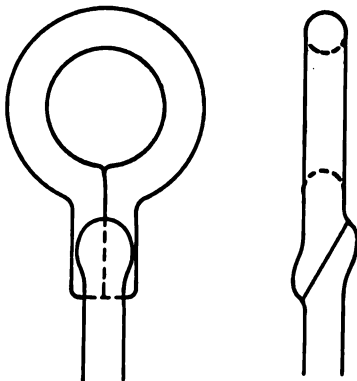

FIG 378.—Forging an Eyebolt.

(8) **Forging an Eyebolt.**—A bar of round iron of the size required, is bent to the shape of the eye, with the ends closed together in a swage as shown in Fig. 378, and the scarf prepared by jumping up both ends. The bar to form the shank, which is usually somewhat larger in diameter, is likewise scarfed as shown. The ends of the ring

are welded together, and the shank welded on simultaneously at one and the same heat. If the bolt is to be made with a collar, a ring bent from square bar with the ends scarfed, is

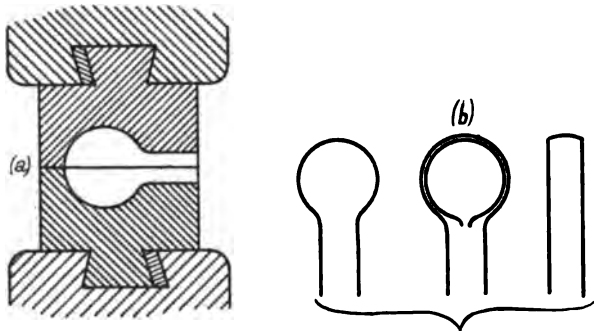

FIG. 379.—Forging Eyebolt under Steam Hammer.

welded on to the shank and the ends welded together at one operation. A better method by which the welds may be avoided, is to draw down the shank from a bar of larger section,

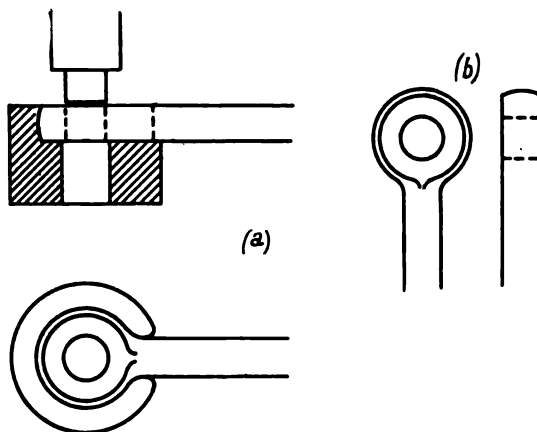

FIG. 380.—Die for Punching Hole in Eyebolt.

leaving a lump on the end which is worked into a spherical shape between dies under the steam hammer, Fig. 379 (a). The ball is then flattened out with the flatter, Fig. 379 (b), and the hole punched, and as both operations are liable to cause the iron to split they must be conducted at a welding heat. For the same

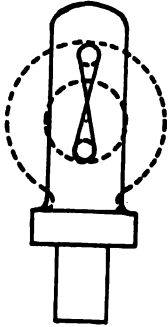

FIG. 381.—Forging Large Eyebolt.

reason the hole must be punched right through in a die of the proper shape, Fig. 380 (a), so as to support the eye on the outside and prevent any bursting tendency. The inside of the hole is rounded out by means of a tool like a punch, which is put through first from one side and then from the other, using the same die as before. This is practically the method employed in making eyebolts by drop forging, to be described later. The best possible way of making a collared eyebolt by hand is to forge out of solid from a bar of about $\frac{1}{8}$ inch larger in diameter than the collar, drawing down the shank, and fullering and setting down the eye, which is then finished as above. Occasionally an extra large eye is required, when the eye portion should be forged longer, and split by punching two holes and cutting from one to the other as in Fig. 381. The hole is then opened out on a drift, and the eye rounded inside and out on the beak of the anvil.

(9) **Forging a Hoop.**—It is usually accounted a good test of workmanship to make a ring or hoop accurately, the proper allowance for scarring constituting a difficulty requiring some skill and experience. The length of circumference + allowance for welding having been cut off from a bar of the proper section, the ends are

by hand is to

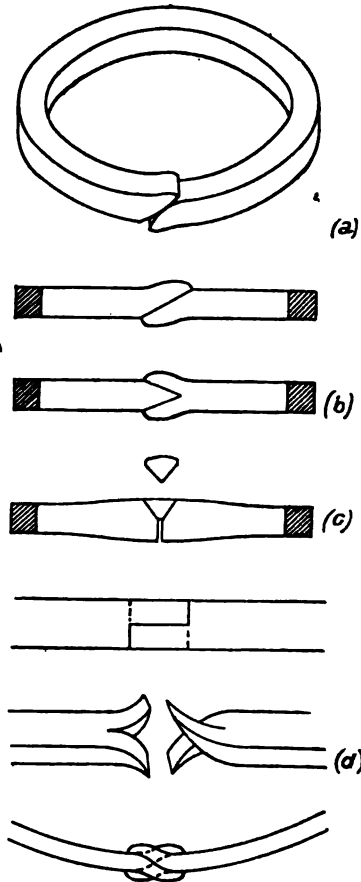

FIG. 382.—Forging a Hoop.

scarfed, practically in the same manner as when welding straight pieces. For sections up to about 1 inch thick the lap weld will suffice, Fig. 382 (a), for a thickness of, say, 2 inches the fork weld is preferable, Fig. 382 (b), whilst for broad and comparatively thin bar, such as used for cart

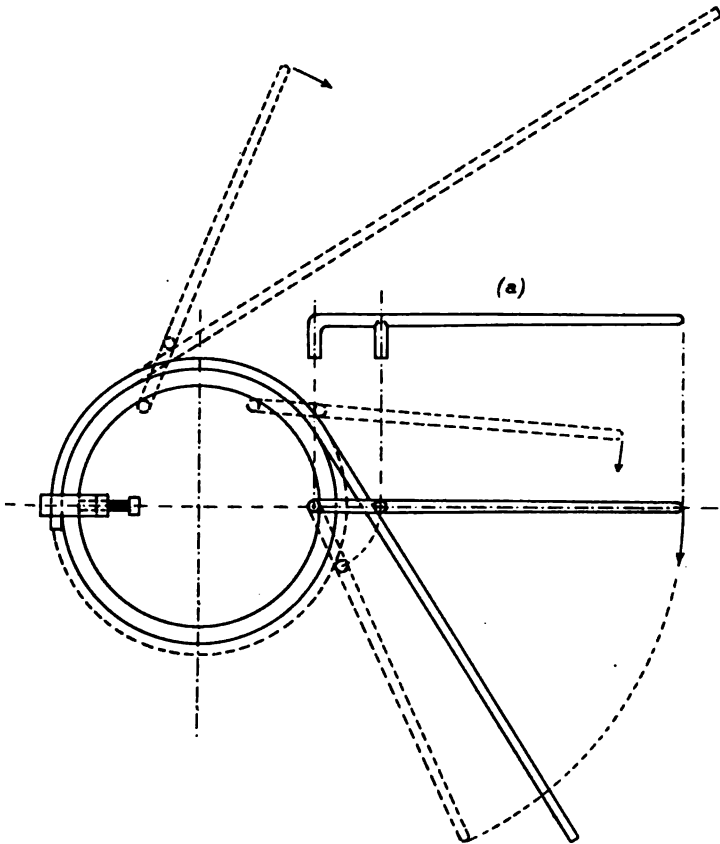

FIG. 383.—Bending Table and Blocking Ring.

tyres, the split weld, Fig. 382 (d), should be used. A method of welding a large hoop preferred by most smiths, especially if of stiff or approximately square section, is to “vee” both ends about halfway across, and to weld in a “glut” of proper size to fill the V, as shown in Fig. 382 (c). After scarfing the ends, the whole piece is heated, and may be

most conveniently bent to shape in a set of bending rolls, or failing that, round a cast iron blocking ring on the bending table, Fig. 383. To bring the bar into close contact with the block, a lever with two prongs, as at (a), used in the manner shown, proves very effective. After bending, the ends are raised to a welding heat, and welded just on the inside on the face of the anvil, and afterwards on the outside over the beak. The ring will now be more or less distorted, and must next be made truly circular, or "rounded," by driving it over a cast-iron cone, Fig. 384, and finally levelled on a block of cast iron, or on the bending table.

Weldless rings are made by first forging a flat disc, through

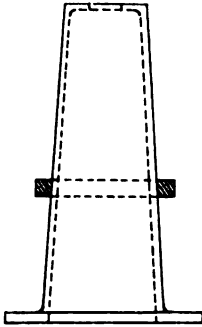

FIG. 384.—Cone for Rounding Hoop Forging.

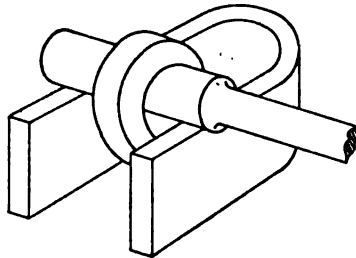

FIG. 385.—Forging Weldless Ring.

the centre of which is punched a hole large enough to go over the beak of the anvil. The punched disc is then gradually forged into a ring, and the diameter may be still further increased if necessary, by forging on a mandrel, making use of the appliance shown in Fig. 385, which is especially suitable when working with a steam hammer. The ring is put upon a mandrel somewhat less in diameter than the hole in the ring, and the mandrel is supported on a rest made from flat bar bent into a U shape, and placed directly upon the anvil. The ring, which is constantly turned upon the mandrel by the tongs, is hammered out on the top, and is thus subjected to a drawing down action, which reduces the section, and therefore increases the circumference. This is, in fact, the principle of the method originally introduced by the late Mr. John Ramsbottom, of Crewe, for making

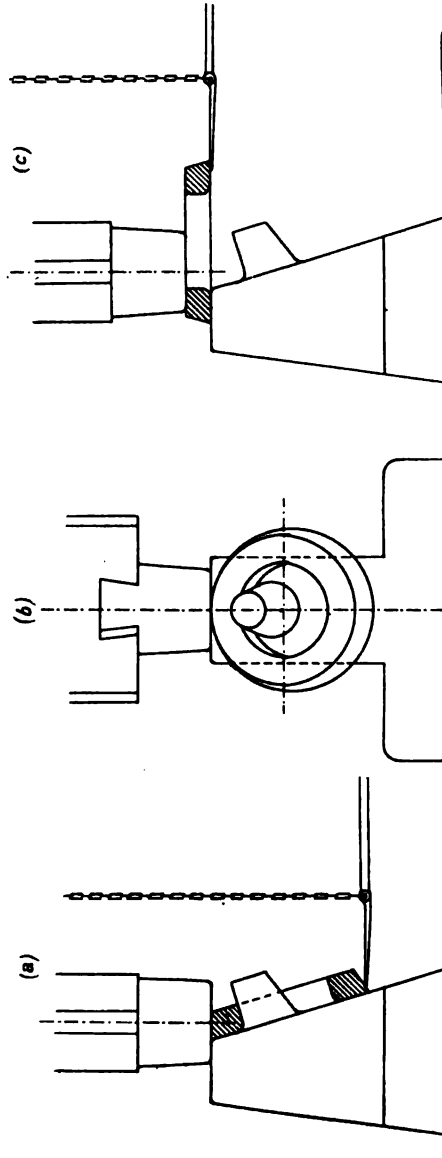

FIG. 386.—Ramsbottom's System of Forging Weldless Tyres.

weldless tyres for railway purposes, suitable tools being fixed to the tup and anvil block of the steam hammer, as illustrated in Fig. 386, (a), (b), and (c). The solid "tyre bloom," Fig. 387 (a), in the form

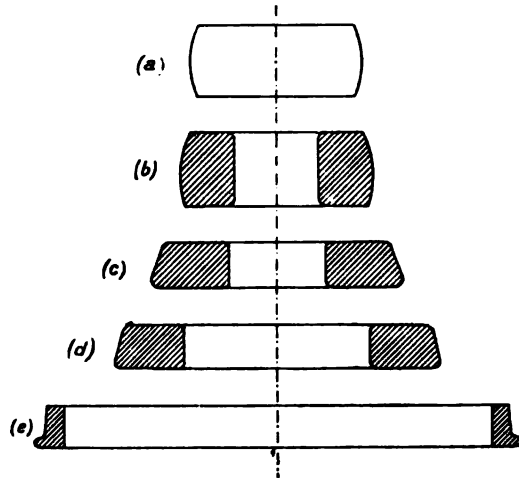

FIG. 387.—Stages in Production of Weldless Tyre.

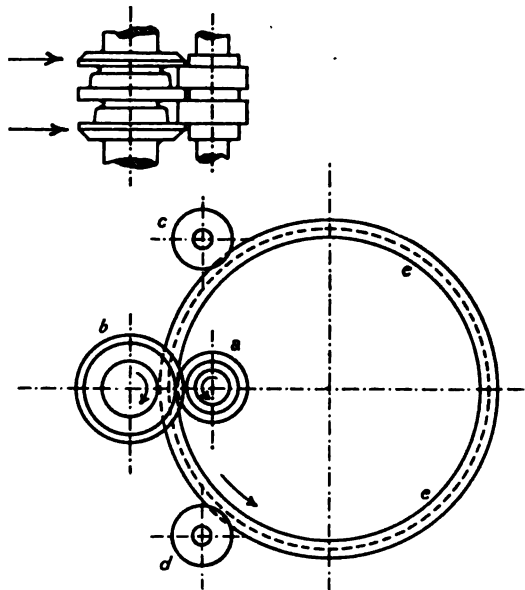

FIG. 388.—Tyre Rolling Mill.

of a flat disc about 20 inches diameter and 9 or 10 inches thick, is first punched under the steam hammer to form a thick ring, Fig. 387 (b). It is then hammered down in thickness until the

diameter reaches about 30 inches, with a hole 10 or 12 inches diameter in the centre, Fig. 387 (c). The next operation is that of hammering out the bloom edgewise to enlarge the hole in the centre, which is done upon the "beak" of the anvil, Fig. 386 (a) and (b), the bloom being rotated vertically between

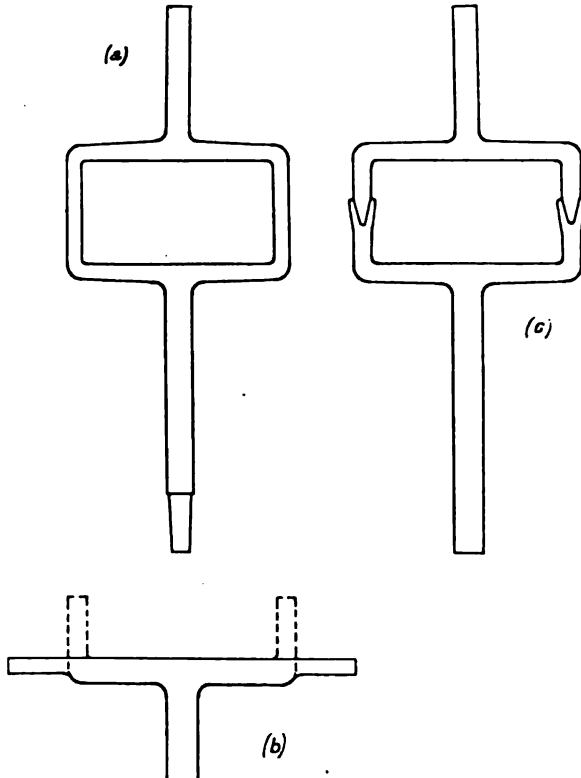

FIG. 389.—Forging Bridle for Locomotive Slide Valve.

consecutive blows by means of a pinch bar suspended by chain, as shown. The ring is next laid flat on the top of the anvil, and hammered all round to correct any spreading produced on the beak. The diameter is now about 34 inches outside, and 19 inches inside, Fig. 387 (d), when the ring is ready for finishing on the tyre rolling mill, shown diagrammatically in Fig. 388. The thick ring of trapezoidal section is placed on the table of the

machine between two rolls, the inner one of which, *a*, bears against the inside of the tyre and is of cylindrical form, while the outer roll, *b*, is grooved to correspond to the desired section of the tyre. Usually two grooves are provided, one for roughing and the other for finishing, as shown. The two rolls are separated to introduce the ring, *e*, when roll, *b*, is set in motion, and at the same time is moved gradually forward in its bearings by a hydraulic ram. As the ring revolves its section is thus reduced, the diameter of course, being increased in consequence. Two rollers, *c*, and *d*, serve to guide the tyre and preserve the truly circular form. The finished tyre is shown at Fig. 387 (*e*).

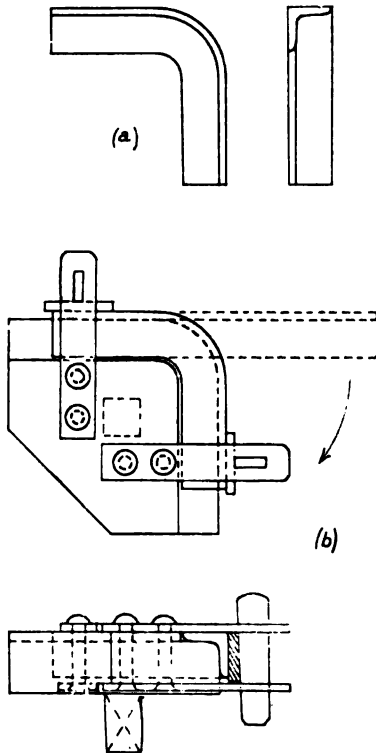

FIG. 390.—Bending an Angle Knee or Bracket.

of angle rings, etc., as required in boilermaking and bridgework, forms a special branch of the trade. Although the hydraulic flanging press is now largely used for such work, a considerable number of the smaller pieces, and those of special shape, remain to be done by hand. The hearth employed by the angle smith is perfectly open, with a clear space all round, so that pieces of any length and shape may be handled without difficulty. To bend or

and at the same time is moved gradually forward in its bearings by a hydraulic ram. As the ring revolves its section is thus reduced, the diameter of course, being increased in consequence. Two rollers, *c*, and *d*, serve to guide the tyre and preserve the truly circular form. The finished tyre is shown at Fig. 387 (*e*).

A Slide Valve Bridle or Buckle, Fig. 389 (*a*), is not forged from solid, but is made by welding. A T-end is forged upon each of the round rods by the method already described, Fig. 389 (*b*). The side portions are then bent to shape, as shown dotted, by the aid of a special tool, and the ends scarfed for welding, Fig. 389 (*c*). The spindle end is afterwards welded on, and the whole set to template.

Angle Smithing.—The bending of rolled sections, welding

crank a knee or bracket of angle section, Fig. 390 (a), a cast iron block of the proper size and shape, fitted with some simple means for clamping the bar, must be provided. Should only one or two pieces of the same pattern be required, it will prove most economical to make a block for this, or any similar kind of work. A very convenient style of block is shown in Fig. 390 (b). The angle is heated at the bend, and one end clamped to the block, the other end being gradually drawn up to the second fastening, as shown. As the angle iron is bent, it will be found that the top flange will tend to pucker up on the inside of the bend, which must be prevented by a few blows with the sledge, as required. The second clamp having been secured, any remaining irregularity at the corner

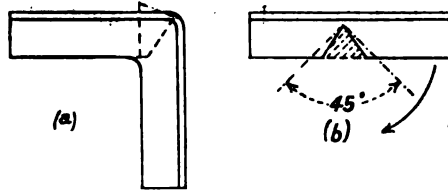

FIG. 391.—Bending a Square Corner in L Section.

is taken out by means of the flatter. In some instances, a square corner, Fig. 391 (a), is desirable, which can only be obtained by cutting out a piece and welding up again, thus adding considerably to the cost. The position of the corner is marked upon the bar to be bent, and an angle of 45° is set off on either side, as in Fig. 391 (b), by nicking with a cold chisel. The corner is then heated, and the small piece section-

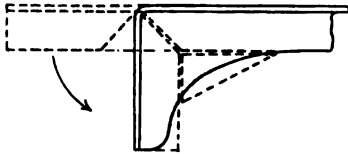

FIG. 392.—Welded Corner in L Section.

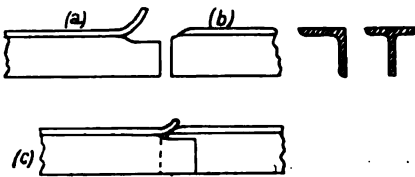

FIG. 393.—Weld in L or T Section.

lined cut out with the hot chisel, after which the edges are scarfed, and the angle iron bent on a block of the proper size, on which it is also welded. Sometimes the weld is made with a "glut," or small piece of bar iron, heated separately, and welded into the corner to supply any possible deficiency of material. Where a curved form, Fig. 392, is required, a glut is welded in,

and afterwards cut to shape with the hot chisel. It is sometimes necessary to make a *weld in angle or tee iron*, and for this purpose also the smith should be provided with cast iron blocks of the proper form. Taking one piece, the flange is cut through at the root, and bent back, the end of the web portion being scarfed as usual for a lap weld, Fig. 393 (a). The end of the

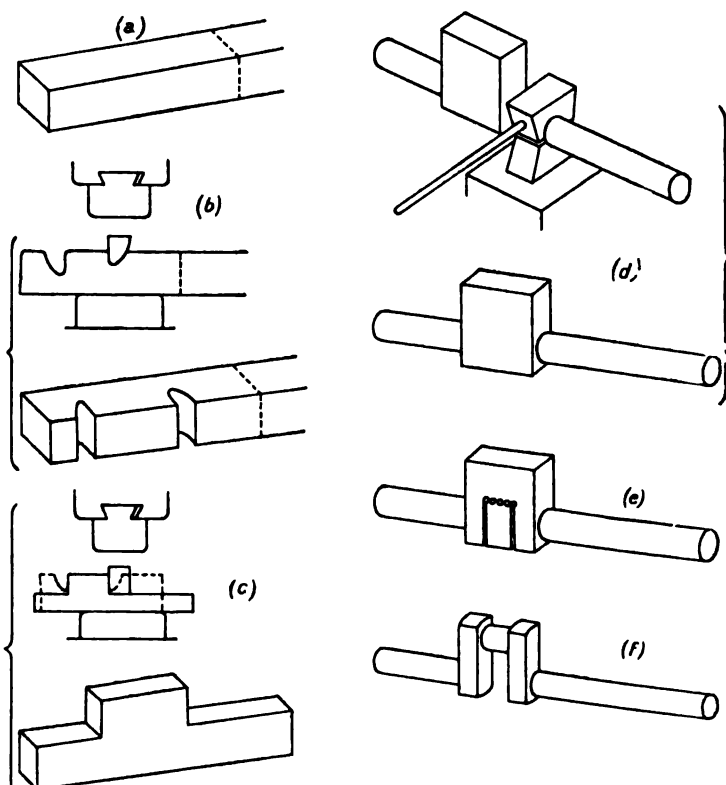

FIG. 394.—Stages in Forging a Crankshaft.

other piece is scarfed as shown at Fig. 393 (b). This figure, it will be seen, applies to both angle and tee iron. The two web portions are then welded together on a raised block to allow for depth of flange, Fig. 393 (c), and the flange is then turned down and welded at a second heat.

In the preceding examples, it has been assumed that the various operations would be performed mainly by hand with the

assistance of a small steam or power hammer of the type usually found in the smithy. In the remaining examples the work is done entirely under the steam hammer, which must also be of the heavier or forge pattern.

Forging a Crankshaft.—The material now almost invariably employed for a crankshaft is mild steel, and the general practice is to forge out of solid by drawing down from a slab. The block forming the crank webs and the space between them is thus left solid, the gap being cut out in the machine shop. The forging will therefore appear as in Fig. 394 (*d*). A row of holes is drilled near the crankpin, and saw cuts taken down the sides of the cheeks for the purpose of removing the gap as in Fig. 394 (*e*). The same method of working is adopted for a double-throw crankshaft with cranks at right angles. The part between the sweeps is removed by cutters, and after the centre portion of the shaft has been roughly rounded, it is re-heated, and twisted to bring the cranks at right angles. The shaft and the crankpins are sometimes rough turned before the twisting takes place. To twist a double-throw crankshaft, the "following" crank is held in place upon the anvil by lowering down the hammer upon it. A large spanner is then attached to the "leading" crank, by which it may be pulled round at right angles. Commencing with the slab, Fig. 394 (*a*), a cut is made with the chisel at each side of the web, and a fuller, shaped as shown, is driven in to open out the groove, Fig. 394 (*b*). A fuller of this shape is adopted to force the end well away from the vertical side of the web, in order to avoid a "cold shut" in drawing down. The end portions to form the shaft are next set down, and the shoulder on each side of the web may be squared up by means of a steel block or set, Fig. 394 (*c*). The ends are then forged out round, and finished between swages, Fig. 394 (*d*). The finished crankshaft after machining is shown in Fig. 394 (*f*).

The crankshafts for motor car engines are produced from a flat slab, Fig. 395 (*a*), by drilling and cutting out the sweeps between the webs, as shown at (*b*) and (*c*), the appearance of the finished article, which is intended for a four-cylinder engine, being indicated at (*d*). More recently, forgings of the proper shape, greatly reducing the cost of manufacture, have been made by stamping between dies of the required form under the steam hammer. The material used is a special alloy steel, such as

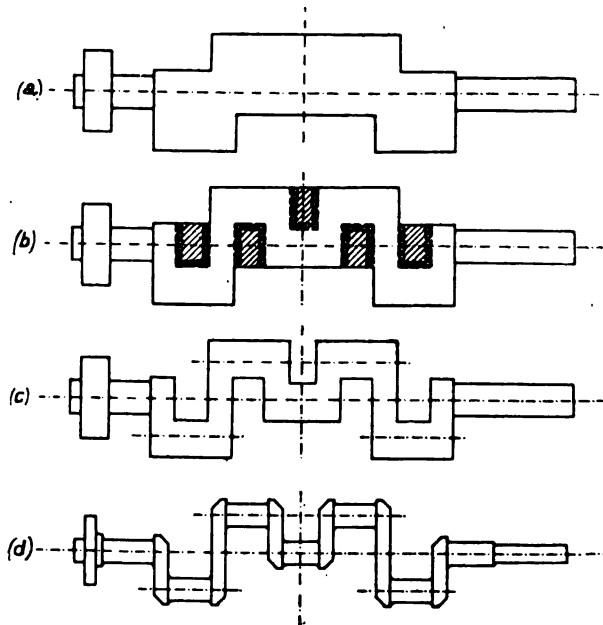

FIG. 395.—Crankshaft for Motor Car Engine.

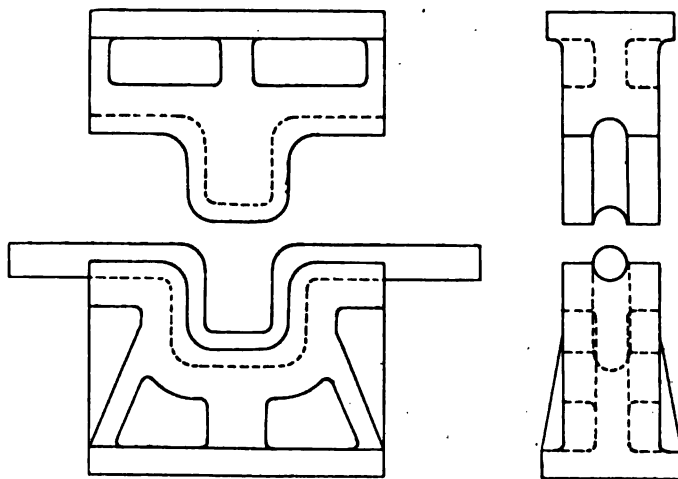

FIG. 396.—Blocks for production of Bent Crank.

nickel-chrome, or chrome-vanadium, which possesses great resistance to shock and fatigue.

The *Bent Crank*, so much used for portable engines, is

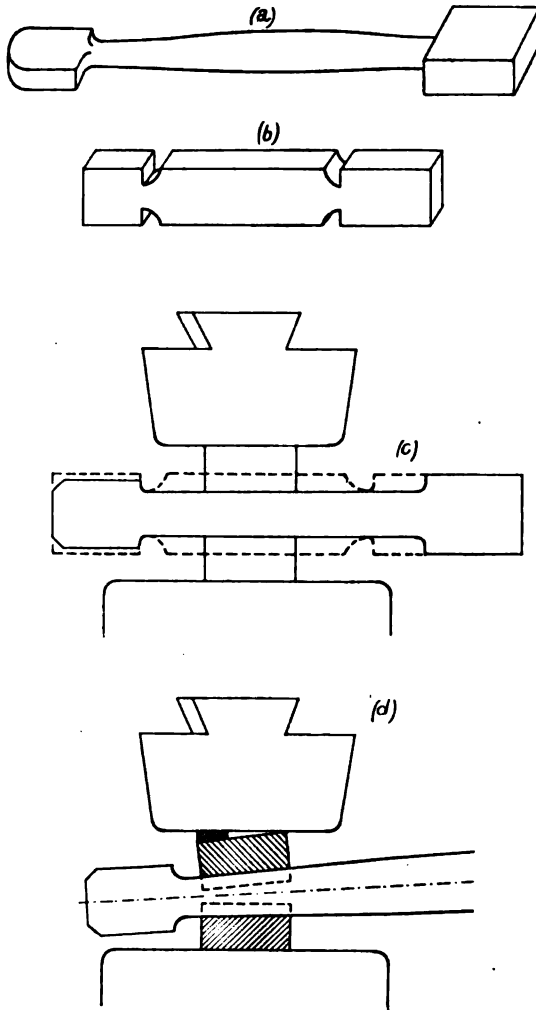

FIG. 397.—Forging a Connecting Rod.

produced entirely from a round bar, preferably of best Yorkshire iron, which by blows of a powerful steam hammer is gradually squeezed into cast iron blocks resembling dies used for stamping,

Fig. 396. The blocks are jointed on the centre line of the crank, as shown. Crankshafts made by this process are open to

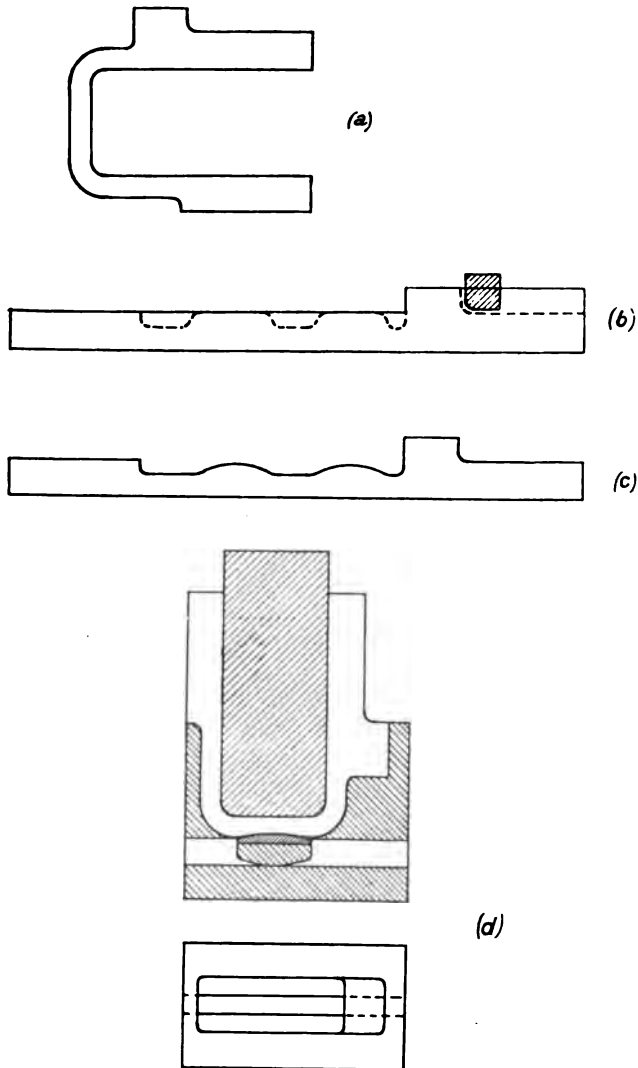

FIG. 398.—Forging Big End Strap for Connecting Rod.

the objection that the crank portion is excessively wide, the circular section taking up much more space than the web of

rectangular form. On the other hand, the fibre of the iron follows the direction of the required shape, instead of being cut through at right angles by slotting the webs out of solid.

Forging a Connecting Rod.—This constitutes another instance of drawing down between shoulders formed by fullering. A connecting rod, Fig. 397 (*a*), whether with solid or T ends, is forged from the solid, the first step being to fuller the slab on both sides at each end, as in Fig. 397 (*b*), using the same fuller as described for crankshaft, with a second and similar tool immediately below, (see Fig. 394 (*b*)). The material between the grooves is then drawn down to the proper size, using sets to clear the end portions, if necessary, Fig. 397 (*c*), and the round rod is finally finished between swages, the taper or bellied form being given, as in Fig. 397 (*d*). As will be seen, the swages are canted by inserting a piece of steel packing placed square across and flush with the end, or a piece of ordinary flat bar may be laid across the end with the same result.

Forging Big End Strap for Connecting Rod.—The following interesting example of the method of forging the big end strap of a locomotive connecting rod, shown in Fig. 395 (*a*) in its finished state, is given by Mr. G. Hughes, Chief Mechanical Engineer of the Lancashire and Yorkshire Railway, Horwich. It is made from a bloom, which in the first place is drawn down to the shape shown in full lines in Fig. 395 (*b*). The deep end is then set down by the tool shown to leave the oil cup, and the knees are set in with a fuller, as in dotted lines. This is done to provide the necessary thickness for the corners in bending, on the principle explained at p. 475. The strap, Fig. 395 (*c*), is now ready for bending, which is performed in the cast-iron block shown in Fig. 395 (*d*). At the bottom of the recess is placed a small curved plate, resting upon a block, the underside of which is tapered at the ends. The use of the plate ensures well rounded corners, with plenty of metal for working up afterwards. The strap is liable to become wedged in the block during the process of bending, and may be released by driving a couple of keys beneath the tapered support. A few blows of the hammer upon the end of the rectangular block transmitted through a making up piece, if necessary, are sufficient to bring the strap to the required shape.

CHAPTER XXXIV.

THE FORGE AND ITS EQUIPMENT.

It is not possible to lay down any definite distinction between the work of the smithy and the forge. As a general rule, it may be said that the forge is attached to, and forms a part of, the works where the material itself, whether iron or steel, is actually manufactured. Most engineers, therefore, obtain their heavy forgings direct from the steelmakers, and these forgings are frequently supplied rough turned to save cost of carriage, and to enable the maker to satisfy himself that the forging is free from any flaws or defects before leaving the works. In many cases, the rough forgings prepared in the forge are subsequently finished in the smithy, the province of which is to deal with the lighter and more exact descriptions of work. A great endeavour is constantly being made by resorting to the use of special tools, and of dies for stamping, by the employment of steel castings, and by machining parts out of the solid, to reduce the work of the smith to an absolute minimum.

Forge Hammer.—The requirements of the forge necessitate the use of several different sizes of steam hammer, in order that each may not be called upon to deal with anything beyond its power. It is well known that with a hammer too light for its work, great danger of "piping" in the centre results from the "flow" of the metal taking place only on the outside. It has already been explained that on account of the resistance to sudden impact due to the inertia of the mass, the effect of the blow is largely expended on the exterior of the forging, penetrating only very slightly to the centre. The sizes of hammer in common use are about 5, 10, and 15 tons, anything larger than the latter being now rarely met with. For large and massive steel forgings, the slowly applied and powerful pressure of the hydraulic forging press has practically superseded the steam hammer. A very convenient type of forge hammer, Fig. 899, with standards of cast steel, the tup, etc., weighing

6 tons, is made by Messrs. Thwaites Brothers, Ltd., of Bradford, and is particularly suitable for heavy work. Although ease of manipulation and convenience in working must continue to be of primary importance, much attention has recently been given to the reduction of steam consumption. A serious loss in the working of a hammer may occur during the latter part of the stroke when the piston is travelling at such a velocity that

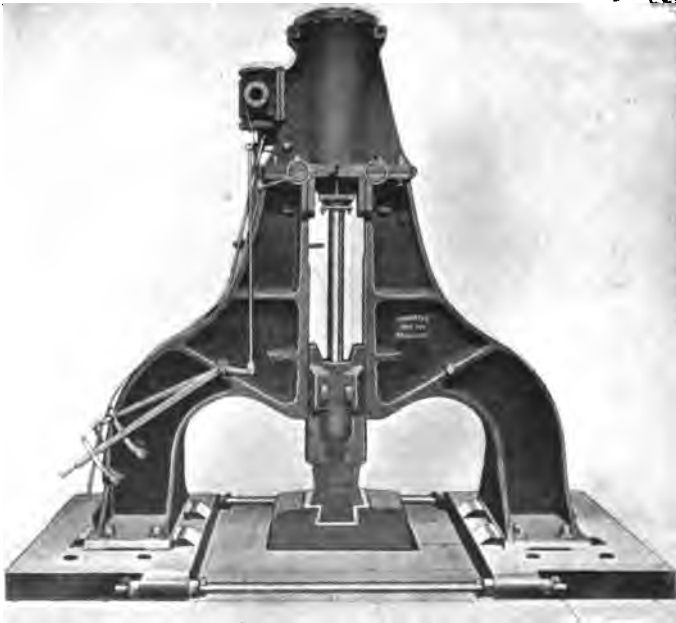

FIG. 399.—6-ton Forge Hammer for Heavy Work.

the pressure in the cylinder at the moment of striking the blow may actually fall below the supply pressure. A quantity of steam is therefore wasted in merely filling up the cylinder to a pressure equal to that of the supply. To remedy this defect, Messrs. Thwaites have patented the special arrangement of valve gear shown in Fig. 400, which gives a sharp automatic cut-off at that point in the stroke calculated to produce the best results. The action of the gear is somewhat similar to that described at p. 463. When the tup rises to the top of the stroke, the pin,

G, moves the tripper, F, with its lever, H, and through the rod, E, the Corliss cut-off valve, B, into the position shown in Fig. 401 (c). This causes the port C to open to full pressure, which is always maintained in D when the stop valve is open. On raising the working valve, A, steam is admitted through the port J, to the upper side of the piston for striking the blow. As the tup descends, the pin, G, moves the tripper lever, F, and Corliss valve, B, to

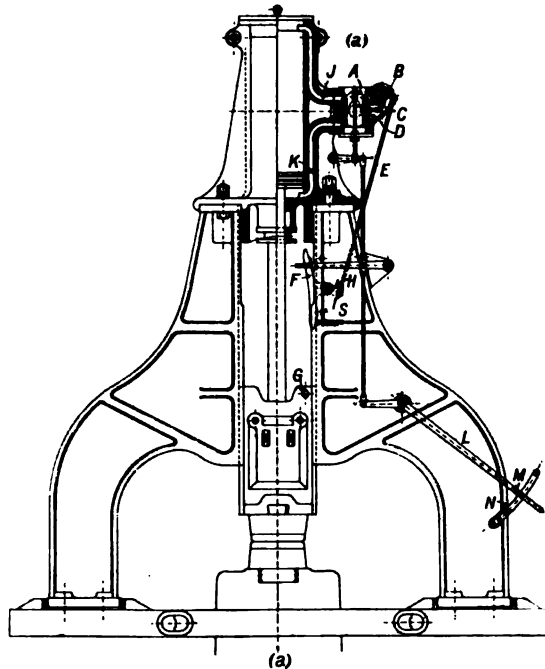

FIG. 400.—Valve Gear of 6-ton Forge Hammer.

the position shown in Fig. 401 (a). When the tup has fallen about half-stroke, steam is automatically cut off, and no more can be admitted unless the working valve, A, is raised to the position for "holding down," as shown in Fig. 401 (b). The travel of the hand lever, L, for ordinary working is regulated by the stop pin, M, catching the spring, N. For holding down, the pin on the hand lever depresses and moves over the spring. Fig. 401 (d) shows position of working valve, A, for "holding up."

The author is indebted to Messrs. B. and S. Massey, Ltd., of

Manchester, for the interesting photograph, Fig. 402, of a view in a forge, showing the arch form steam hammer usually employed,

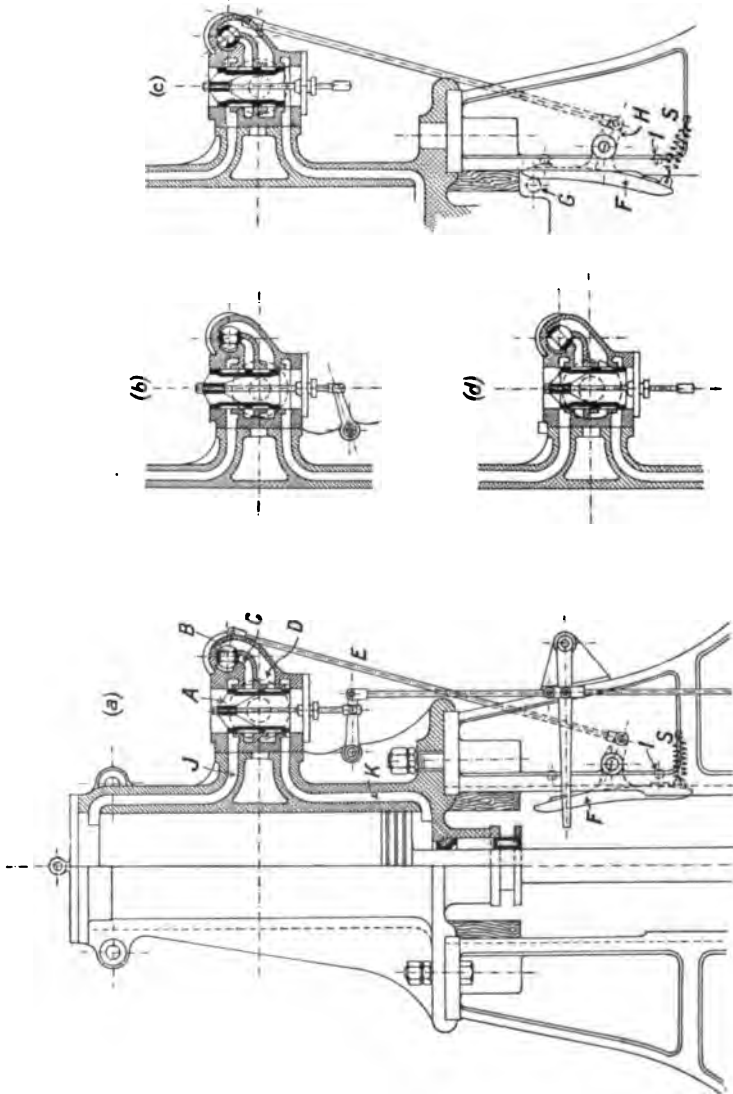

FIG. 401.—Action of Valve Gear of 6-ton Forge Hammer.

the heating furnace, and the crane for transporting the work from the furnace to the hammer. The hammer is provided with

Messrs. Massey's patent valve gear, Fig. 403, by which it is claimed an economy in steam consumption of from 30 to 40 per cent. may be effected. Suppose the valve to be placed in the position (*c*), steam is admitted to the underside of the piston, and the top of the cylinder is opened to exhaust. The hammer



FIG. 402.—View in Forge.

then rises, and in so doing automatically rotates the valve, the roller on the end of the bell-crank lever seen in (*b*) running in an inclined groove at the side of the tup (*a*), to give the required movement. This cuts off the steam and closes the exhaust port. The steam below the piston thus acts expansively for the remainder of the stroke, and the compression above the piston brings the

hammer safely to rest. Very fine bye-passes are arranged (*d*), so that when the hammer is at the top of its stroke just sufficient steam is admitted below the piston to keep it suspended. On

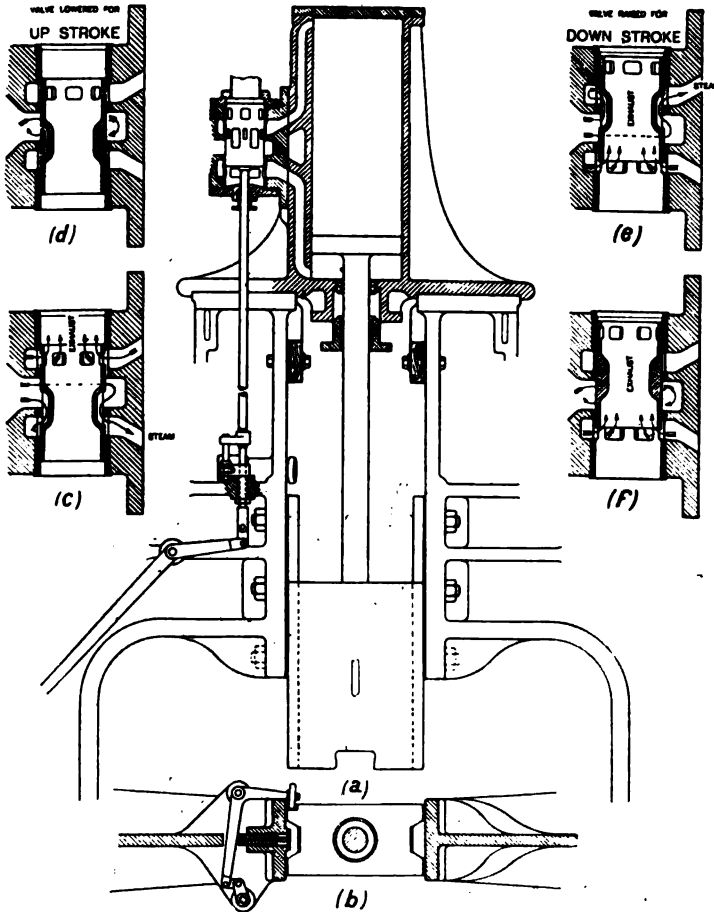
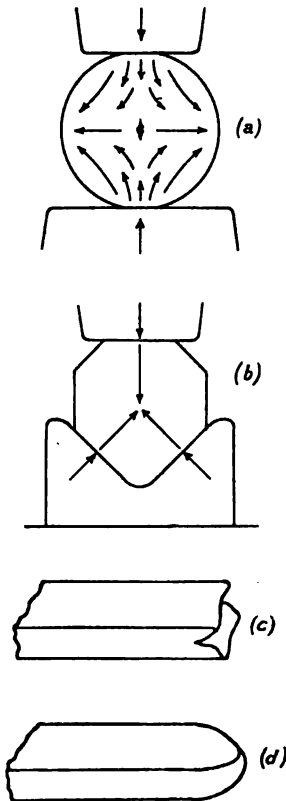

FIG. 403.—Automatic Cut-off Gear for Forge Hammer.

moving the valve into position (*e*), the bottom of the cylinder is opened to exhaust, and steam is admitted above the piston for striking the blow. As the tup descends, the valve is rotated back again, until at half-stroke steam is entirely out off, as in (*f*), and acts expansively for the remainder of the stroke. For

holding down, supplementary ports are provided, which come into operation when the hand lever is depressed a little below mid position. A longer travel given to the valve closes these ports for ordinary working.

Forging Press.—The jar due to the blow of a heavy steam hammer is the cause of frequent breakage of parts, and of considerable wear and tear, not only of the hammer itself, but also of cranes and the rest of the plant, and the excessive vibration is most destructive to the roof and building, and damaging to the surrounding property. It has been found that the limit for economical working is reached with a hammer of about 12 tons, beyond which the cost of depreciation and repairs becomes very serious, and for this reason alone, very large hammers have always been failures. The effect of a heavy blow is almost entirely confined to the surface, and does not penetrate into the interior of the forging. Hence the hydraulic forging press, first introduced, in 1861, by John Haswell, engineer of the Austrian State Railways, has now displaced the steam hammer for the production of heavy forgings. In place of the short, sharp blows of the hammer, which tend to spread the metal on the outside only, hydraulic pressure may be maintained undiminished and without shock for any required length of time, the effect being thus transmitted to the inner-



most portion of the work. At the same time, all losses due to jarring and vibration are entirely avoided, and the great expense of heavy foundations is saved. The difference between the action of the hammer and the press is well shown in the sketch, Fig. 404. The action of the hammer is to produce radial compressions at opposite points round the circumfer-

ence of the work operated on, as shown in Fig. 404 (a). These radial compressions are resolved into diagonally acting forces diverging from the points of application on the faces of the hammer and anvil respectively. The combination of the two sets of diagonal components produces diametrically opposite forces, acting through the centre of the mass at right angles to the original pressure. The denser metal on the outside thus bulges laterally, while the weaker portion at the centre tends to rupture under the action of the forces applied across all diameters brought in succession into a horizontal position by the rotation of the work. This ruptured centre is not found in heavy press forging, where V-shaped anvils are used for making round shafts, the result being to produce as nearly as possible equal pressure radially through the centre of the piece, as seen at (b). When making a steel bloom, say for a crankshaft, the result of cogging down a large ingot under the hammer, or by rolling, is seen at (c), the shape of the end being due to the drawing of the metal on the outside while the interior receives far less treatment. If cogged down under a press, the end of the bloom is of convex form, as at (d), proving that the force exerted is transmitted quite to the interior. When first employed, the slow working of the press was found to be a disadvantage, but the difficulty has been overcome, and even in the larger sizes, a rate of 40 strokes per minute is now possible. Several types of forging press are in use, viz.: (1) Working with water pressure supplied direct from a pump. With this system, high-pressure water must be used for making adjustments, with consequent loss in efficiency, and the pump, having to pick up at any time, must be of the direct-acting or duplex type, which is notoriously wasteful in steam consumption. As the pressure has to be pumped up afresh for each stroke of the press, the action is necessarily very slow. The only advantage possessed by this system is that the first cost of the installation is low. (2) Working with water pressure derived from an accumulator. In this case, the pump runs continuously, work being stored up in the accumulator until required by the press. The pump may therefore be of the most economical pattern as regards steam consumption, or may be driven by belt or electric motor, as most convenient. A smaller size of pump will also suffice, and as the full water pressure is at all times ready for use, the press

may be worked at a much higher rate, up to 40 or 50 strokes per minute. As in the first system, the "clearance part" of the stroke has to be made and all adjustments effected by using high-pressure water, which much increases the cost of working.

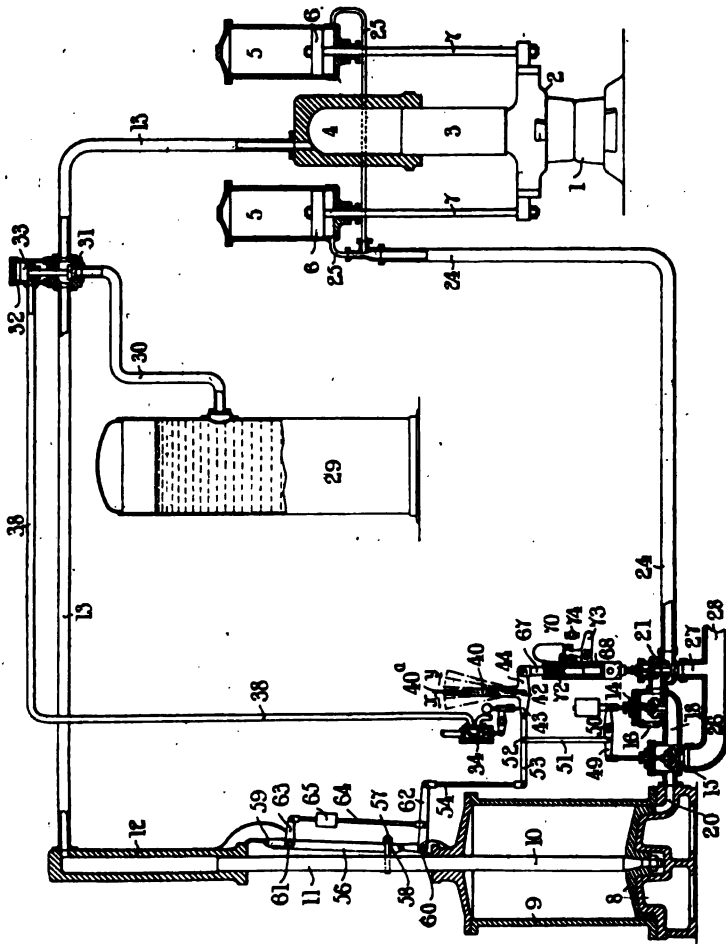

Fig. 405.—Diagram of Hydraulic Forging Press.

(3) Using low-pressure water at a pressure of about 60 lbs. per square inch for filling up and adjusting, the tup being raised by steam pressure, and a steam intensifier being employed for giving the actual squeeze. In this system, which has been adopted by Messrs. Davy Brothers, Ltd., of Sheffield, Messrs. Fielding and

Platt, of Gloucester, and others, no pumping engines are required. As, however, in forging, the maximum pressure must always be available at the end of the stroke, it is not possible to work the steam expansively in the intensifier. The steam consumption is therefore relatively very high, probably exceeding that of the steam hammer. On the other hand, the press is simple in construction, and is very easily operated at a high rate of speed. (4) Working with water pressure from an accumulator for adjusting movements, the actual squeeze being given by a steam intensifier. This principle has been very successfully applied in many presses of the largest size.

A type of press, operated by means of steam hydraulic intensifier, of which a number have been made by Messrs. Davy Brothers, Ltd., of Sheffield, is illustrated at pp. 534 and 535, the various parts in a position of rest being shown diagrammatically in Fig. 405, and an enlarged view of the "handing lever" and valves in Fig. 406. At 1 is the anvil or bed die; 2 is the press head; 3 the main hydraulic ram carrying the press head, and working in the main cylinder 4; in the lifting cylinders 5, 5, work pistons 6, 6, coupled by rods 7, 7, to the press head 2; 8 is the steam intensifier piston working in the cylinder 9, and having a piston rod 10, which forms the hydraulic ram 11, of the intensifier; 12 is the cylinder in which the hydraulic ram works, and which by the pipe 13, is connected with the main cylinder 4. Steam from the boiler entering at 16, is admitted to the underside of the intensifier piston 8, by the double-beat valve 14, a similar valve 15, regulating the exhaust. The supply and exhaust of steam to and from the lifting cylinders 5, 5, are controlled by a piston valve 21, working in a chamber which communicates by means of the passage 23, with the steam space of the valve 14, and through the pipes 24 and 25, with the lower ends of the lifting cylinders. The exhaust passages 26 and 27, lead into the main exhaust pipe 28. The air vessel 29, is connected by the branch pipe 30, to the hydraulic high pressure pipe 13, through the valve 31, which under normal conditions is held closed by the pressure in the pipe 13. When the rams 3 and 11, descend by their own weight, they tend to create a partial vacuum in the hydraulic high-pressure system, and the valve 31, opens automatically under the pressure of the air vessel 29, so as to allow the pipe 13, and cylinders 4 and 12, to become filled with low-

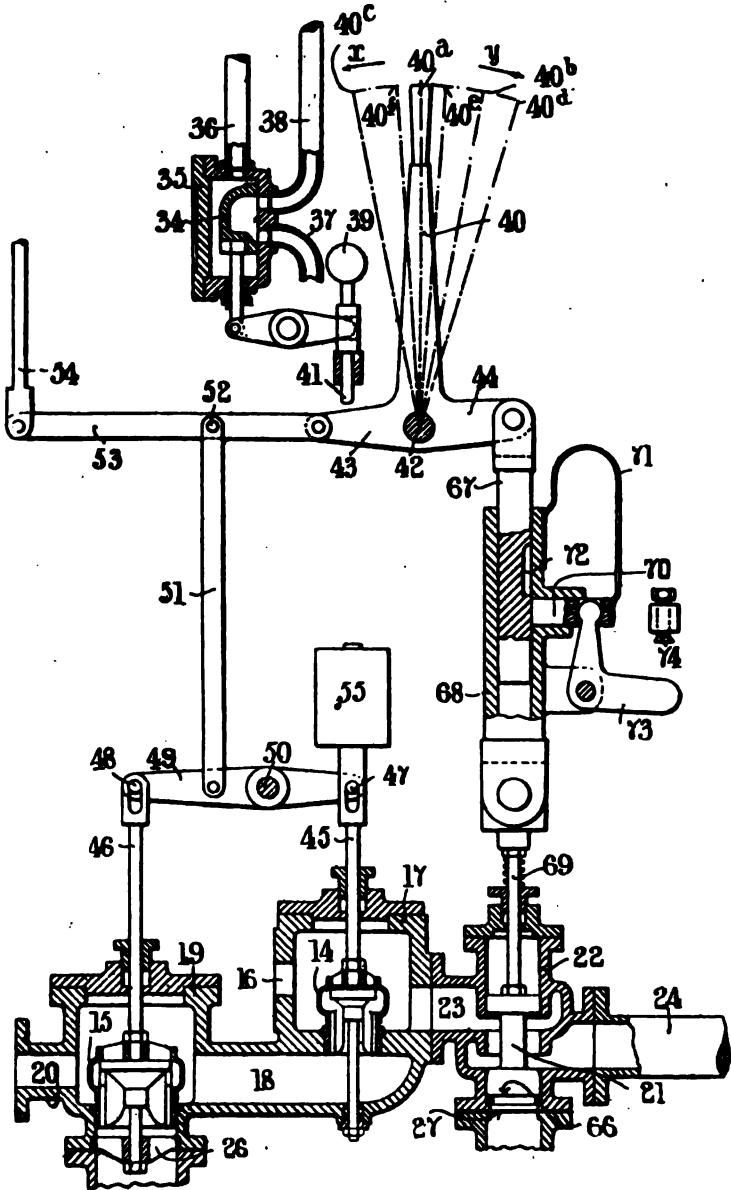

FIG. 406.—Handing Gear for Hydraulic Forging Press.

pressure water. The air vessel is kept charged at a pressure of about 60 lbs. per square inch by a separate pump. When the system is full of water, and the ram 8, is to be raised preparatory to making a working stroke, the valve 31, is opened positively to allow water to be returned to the air vessel. This is effected by admitting water pressure to the underside of the piston 33, which is coupled to the valve 31. The admission and exhaust of this pressure is controlled by a slide valve 34 (Fig. 406), the movement of which is effected at the proper time through the tappet 41, coming in contact with the arm 43 of the handing lever 40. The latter has three arms, one of the shorter of which 43, is coupled up to the mechanism for working the intensifier valves 14 and 15, and the other arm 44, gives motion to the piston valve 21, appertaining to the lifting cylinders. The intensifier valves 14 and 15, are actuated by the automatic "hunting gear," the object of which is to cut off the supply of steam to the cylinder 9, at a point in the stroke of the piston 8, corresponding to the angular position to which the handing lever is moved, thus limiting the movement of the intensifier piston in the upward or active direction to the amount required to give either long or short strokes as may be desired in working the press. A bar 56 (Fig. 405) extends obliquely alongside the intensifier ram 11, and is supported at 58 and 59, on bell-crank levers 62 and 63, which turn on fixed centres 60 and 61. The bar is moved transversely to its length by the roller 57, mounted upon the ram 11, and is maintained in the normal position by the counterweight 65. The arm 62, of the lower bell-crank lever is coupled by a link 54, to the "floating lever" 53, of the differential gear. (See also Fig. 406.) Suppose now the handing lever 40, is moved to the left, or into the position assumed when the press head is performing a working stroke. The end of the link 54, is for the time being virtually the fulcrum of the lever 53. Hence 51 is depressed, and the lever 49, opens the steam valve 14, admitting steam to the underside of the intensifier piston 8, which therefore commences its upward stroke. The action of the roller 57 (Fig. 405) draws in the upper end of the bar 56, which through the bell-crank lever 62, lifts up the link 54. The end of the arm 43 (Fig. 406), of the handing lever, being at rest, has now become the fulcrum, and the upward motion of the link 54, is imparted to the floating lever 53, and by the link 51, to the valve lever 49, causing the valve to close when the piston 8, has per-

formed the same fraction of its full working stroke as corresponds to the angular displacement of the handing lever. The piston valve which admits steam to the lifting cylinders is normally disconnected from the handing lever, and rests by gravity on a stop 66, in such a position as to admit steam to the underside of the lifting pistons 6, 6. To cut off the steam supply and open the lifting cylinders to exhaust, the handing lever must first be moved towards the right, to pick up the trip mechanism by which the valve 21, is raised. The plunger 67, which is permanently coupled to the lever arm 44, slides in a socket 68, permanently attached to the spindle 69, of the valve 21. The two parts 67 and 68, are caused to engage and disengage with each other automatically by means of a bolt 70, which is pressed inwards by the spring 71, and enters a notch 72, cut in the side of the plunger 67. When engagement has taken place, the valve 21, will participate in the upward movement of the arm 44, until the socket 68, has been raised so as to cause the lever 73, to strike the fixed stop 74, when the bolt 70, will be withdrawn from the notch 72, and the socket 68, together with the valve 21, will be free to fall, the latter returning to its normal position on the seat 66. With the parts in the position shown in the figures, and the handing lever in its mid or neutral position 40 (*a*), both main and intensifier rams 3 and 11, resting at the bottom of the stroke, the hydraulic cylinders 4 and 12, and connecting pipe 13, are full of water, and consequently, so long as valve 31 remains closed, no upward movement of the ram can result from steam pressure on the pistons 5, 5. To set the press in operation, water must first be exhausted from the cylinder 4, by opening the valve 31, which is effected by moving the handing lever towards the right into position 40 (*b*), when the arm 43, of the lever strikes the tappet 41, as above described. The lifting pistons then raise the main ram 3, and press head 2, sufficiently to accommodate the work on the anvil 1. If now it is desired to work the press with short and rapid strokes, a permanent cushion of live steam is required beneath the pistons 6, 6, and exhaustion of the cylinders 5, 5, is therefore not necessary. The handing lever is moved directly back from 40 (*b*), to some point (depending on the length of stroke required), to the left of its neutral position 40 (*a*), between which and the extreme left hand position 40 (*c*), it may then be oscillated to and fro. This will cause the ram 3, to be driven down

repeatedly and rapidly in opposition to the steam pressure on the pistons 6, 6, by which it is promptly raised at each reversal of the handing lever. If, however, it is desired to work the press with long and relatively slow strokes, it is necessary to exhaust the lifting cylinders 5, 5, to allow the presshead to drop, and to re-admit steam to them slightly before the end of the pressing stroke in readiness for raising the ram promptly the moment reversal of the stroke of the press head is required. To effect this, the handing lever must be moved beyond the position 40 (*b*), towards the right, until on arriving at 40 (*d*), the trip gear 70, engages. The handing lever is now reversed, causing valve 21 to rise, and on reaching position 40 (*e*), steam is cut off from the lifting cylinders, which will also then begin to exhaust. Hence the press head, having thus been raised to the desired extent, will descend by gravity, drawing water from the air vessel to fill up the hydraulic high-pressure system. Continued movement of the handing lever towards the left opens the valve 21 fully to exhaust during the idle descent of the press head, but on reaching the position 40 (*f*), the bell-crank lever strikes the stop 74, the trip gear is disengaged, and the valve 21 falls, closing the lifting cylinders to exhaust, and again admitting steam beneath the pistons 6, 6. Thus the remainder of the working stroke is performed against a cushion of steam during the time taken by the lever to move from 40 (*f*) to 40 (*c*). On the completion of a long working stroke, the handing lever must be returned to the left-hand side of its neutral position, to open the intensifier exhaust steam valve 15. Before another long stroke is commenced, the handing lever is moved to the extreme right-hand position 40 (*d*), after which the entire cycle of operations above described is repeated. To bring the parts to the position of rest, as in the figures, the handing lever must first be moved into the position 40 (*d*), and then brought to and left in the neutral position 40 (*a*). It will thus be seen that all the movements of the press are obtained by means of one handing lever only, which is a very important advantage, much simplifying the driving, and increasing the speed of working. In a 1,200-ton press, the movement of press head per stroke of intensifier may be varied from zero up to 6 inches, and the speed on short strokes may reach 100 per minute. A hydraulic pressure of $2\frac{1}{2}$ tons per square inch is employed, the working pressure of steam being 150 lbs. per square

inch. Fig. 407 is taken from a photograph of the 500-ton high-speed forging press here described. A 4,000-ton press on this

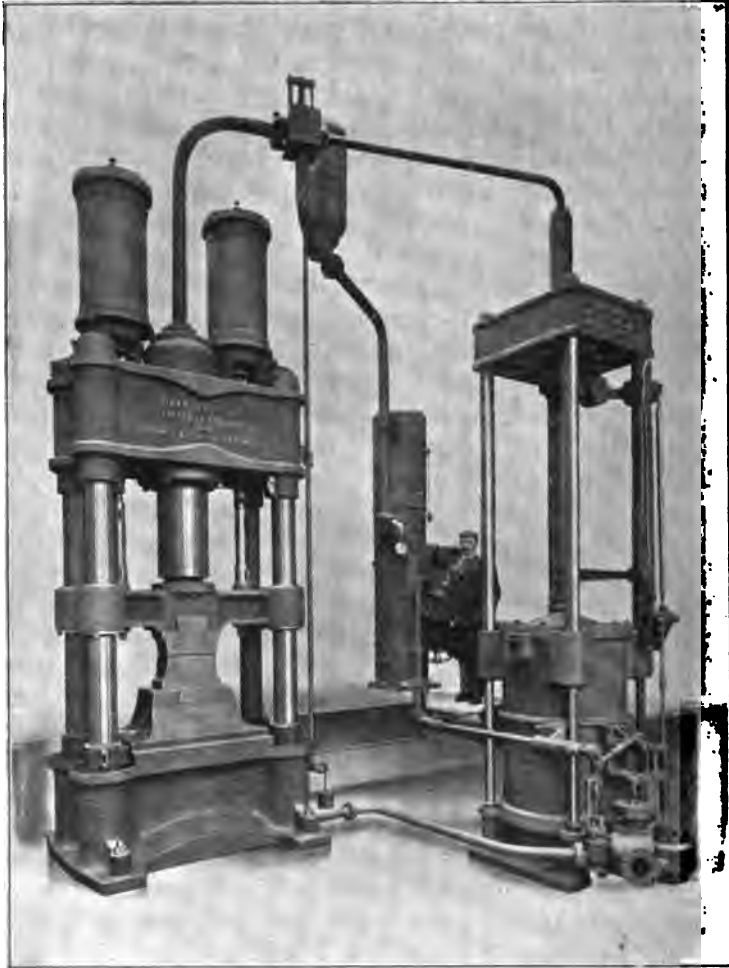

FIG. 407.—500-ton High Speed Forging Press.

system has been erected by Messrs. Davy Brothers at the River Don Works, Sheffield, for Messrs. Vickers, Ltd., who kindly supplied the photograph from which the illustration, Fig. 408, was prepared.

It is sometimes imagined that the forging press is suitable only for heavy work, but recent improvements have enabled the press, even of small size, to compete in speed and economy of



FIG. 408.—4000-ton Hydraulic Forging Press at Messrs. Vickers' River Don Works, Sheffield.

working with the steam hammer for almost all varieties of forging. A 60-ton rapid-action forging press of the steam-intensifier type, made by Messrs. Fielding and Platt, Ltd., of Gloucester, is illustrated in Fig. 409. The press cylinder, A, is formed as a moving slide working within guides, and also upon the fixed ram,

B. The steam intensifier is situated at the rear, R and D being the steam and water cylinders respectively. A steam cylinder H, controlled by slide valve and hand lever, is employed to return

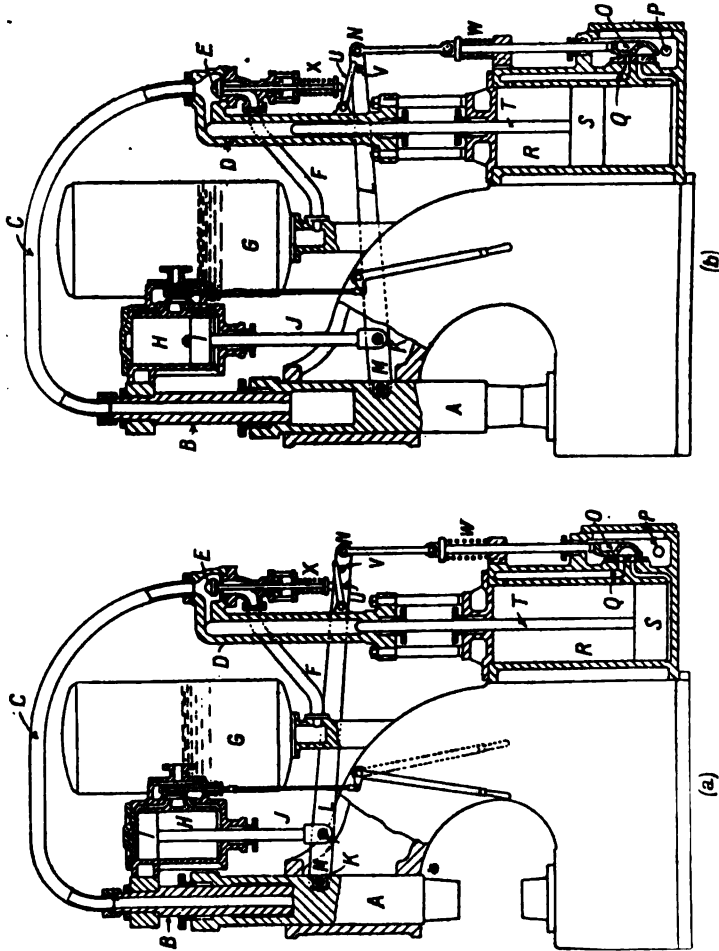

FIG. 409.—60-ton Rapid Action Forging Press.

the parts to the top of the stroke before pressing. G is a water reservoir, in the upper part of which air is compressed to a pressure of 30 lbs. per square inch for use in charging the cylinders B and D, and the connecting pipes C and F, with water. In the position shown in Fig. 409 (a), steam is admitted to the

underside of the piston, I, the upper side being opened to exhaust. The press cylinder, A, is thus raised to the top of its stroke, the piston rod, J, being pivoted at K to a lever, L, attached to the press cylinder at M, which, in this position becomes the fulcrum. The outer end, N, of the lever is therefore raised, as the piston, I, completes its stroke to the position shown, causing the slide valve, O, to open the lower end of the cylinder, R, to exhaust. At the same time the valve, E, is raised from its seat by the auxiliary lever, U, actuated by a pin, V, in the lever, L. Free communication is now established between the reservoir, G, and the cylinders, A and D, which together with the pipes, C and F, are therefore charged with water. The hand lever is now reversed, or put into the position shown in dotted lines in Fig. 409 (a). The slide valve of the cylinder, H, now admits steam to the upper side of the piston, I, which together with the cylinder, A, and lever, L, therefore descends until the top tool comes in contact with the work, Fig. 409 (b). When this occurs, the point of attachment, M, again becomes the fulcrum of the lever, L, and the last portion of the stroke of the piston, I, depresses the joint, K, moving N downwards and causing the slide valve, O, to admit steam to the underside of the intensifier piston, S. Just at the time when the slide valve, O, reverses, the valve, E, closes, shutting off communication with the reservoir, G. Hence when steam is admitted beneath the piston, S, the latter is driven up, producing an intensified pressure in the cylinders, D and A, and causing the press slide to exert its full force. The hand lever is now moved to the position shown in full lines in Fig. 409 (a), and steam being admitted below the piston, I, raises the end of the lever, N, opening the valve, E, and reversing the slide valve, O. The water is thus permitted to return from the cylinder through pipes, C and F, to the reservoir, G, so as to allow the return stroke of the cylinder, A, to be made. The spring, W, is provided to assist in lifting the slide valve, O, and similarly, a spring, X, ensures the seating of the valve, E, when the lever, L, is in the position shown in Fig. 409 (a). It will be seen that all the movements of the press are controlled by a single lever of short stroke, which is a great convenience for rapid operation, and that pressure water is used only when the ram is actually in contact with the forging, thus securing economy in working. In the machine illustrated, Fig. 410, the press ram has a range of 12 inches, and one full stroke of the steam driver

cylinder will give a stroke of $2\frac{1}{2}$ inches on the press ram. This is capable of dealing easily with material 5 inches square, at a rate of 15 to 25 pressing strokes of average length per minute.

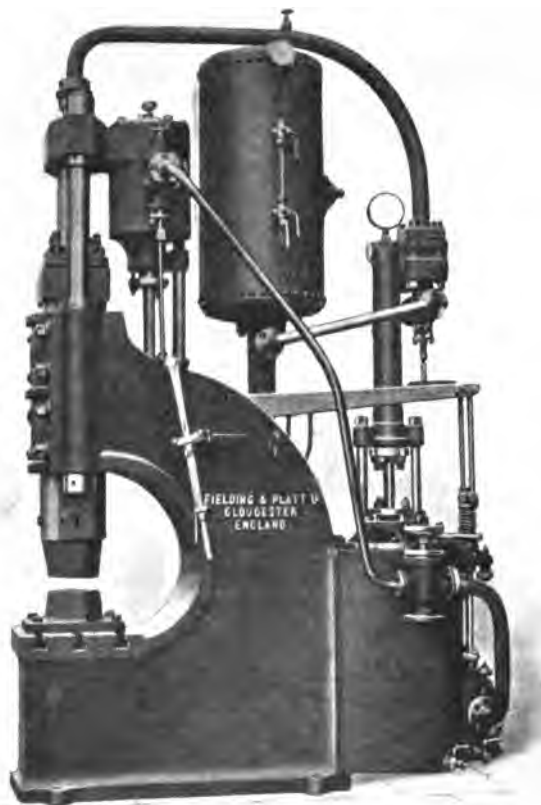

FIG. 410.—60-ton Rapid Action Forging Press.

When the press is required for planishing or finishing forgings, the main cylinder, B, and hydraulic intensifier, D, are shut off from the main press ram, and the small auxiliary steam cylinder, H, is used for working the press exactly as in a steam hammer.

This, of course, strikes very light blows, sufficient for finishing work only. The main frame of the press is a mild steel casting of box section, the main cylinder is of forged steel, and the fixed main ram is of phosphor bronze. The pressure pipes are of solid drawn steel tube 2 inches bore, to allow of quick working.

CHAPTER XXXV.

EXAMPLES OF HEAVY FORGINGS IN IRON AND STEEL.

Iron Forgings are made either from puddled bars, or from hammered scrap. In the first case, the bars are made into a pile, about 18 inches long, 15 inches wide, and 12 inches high, the bars being of different dimensions in each row to cross the joints. The pile is several times re-heated and re-worked to expel the slag and cinder, and is shingled down into a slab, or into billets. "Hammered scrap" is generally specified for engine forgings of wrought iron. The scrap should consist of shearings and punchings from plates, pieces of bar, turnings, etc., and should be well rattled in a foundry tumbling barrel to remove dirt and rust. If care is taken in arranging the pile for heating, and the welding is thoroughly performed, better forgings can be obtained than from puddled bars. For a large forging, several slabs are piled together, with small pieces of iron interposed between them to keep the surfaces apart and allow free access for the flame. The centre is thus raised to the same temperature as the outside, and the whole mass brought to a uniform welding heat. Instead of tongs, a staff or "porter" is used to carry the piece to and from the furnace, and manipulate the forging under the hammer. The staff consists of a long tapered bar, made round so that it may be conveniently rotated within a loop of chain by means of which the work is suspended from the crane. It is welded temporarily to the work, and is used over and over again for many forgings. Either two or four handles may be clamped upon the end of the porter for use as levers in turning about the forging on the anvil by two of the "under men," who are assisted as required by several others in charge of pointed rods or "lifters," similarly supported in slings hanging from light overhead jib cranes. The forgerman himself applies the various tools to the work, and directs operations, giving instructions by signal or otherwise, to the hammerman, and to the different members of the gang. The system of

working will be clearly understood from the photograph, Fig. 411, which shows the operation of forging an engine shaft under an 8-ton steam hammer at the Low Moor Ironworks.



FIG. 411.—Forging an Engine Shaft under 8-ton Steam Hammer.

Making a Shaft Forging.—Bars up to 6 inches in diameter are made by rolling, but if above that size, they are forged under the hammer or press, the additional working to which they are thus subjected serving to develop the full strength of the

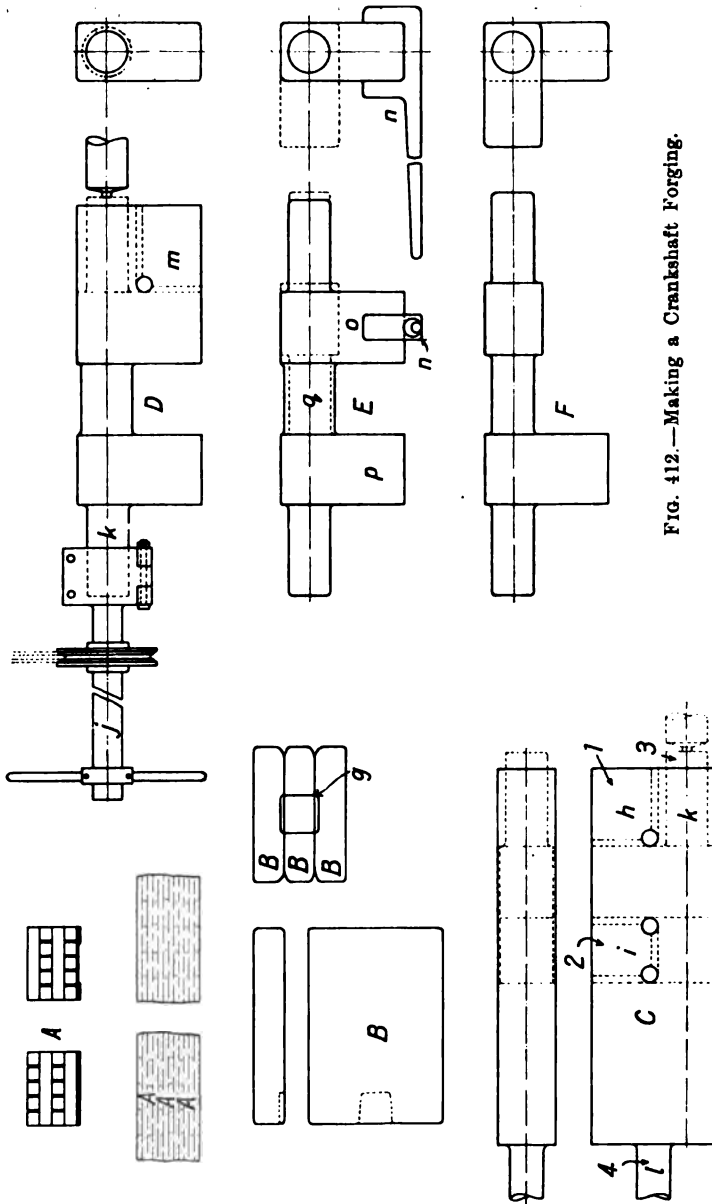

FIG. 412.—Making a Crankshaft Forging.

material. Two or three slabs are placed on a staff, inserted in the furnace and raised to a welding heat. The whole is then

thoroughly welded together into one solid mass under the steam hammer. From this, by drawing down and swaging, the first portion of the round shaft is produced. Further slabs may then be welded on, the piece turned over, and several similar slabs added on the opposite side. The operations of drawing down and swaging are repeated until the required length of round shaft is obtained. If a crankshaft is required, more slabs are welded on both sides until a butt is formed equal in depth to the crank. The method of forging a locomotive or other double-throw crank axle in best Yorkshire iron, as practised at Messrs. Taylor Bros. & Co., Ltd., Clarence Iron and Steel Works, Leeds, may be referred to by way of illustration. Pieces of iron about 11 inches long and $2\frac{1}{2}$ inches square, are "piled" on a wooden board, as at A, Fig. 412. The piles are charged into a re-heating furnace, and raised to a welding heat. Each pile is in turn taken out of the furnace with suitable appliances, as described above, and hammered out flat under the steam hammer. Piles in sufficient number to give the required weight are placed one on top of the other while still hot, and made into a bloom, as at A A A. This bloom is put back into the furnace, raised to a welding heat, and then worked under the steam hammer until a solid slab is produced, as at B. The bloom is re-heated three times in succession, and after each heat is thoroughly hammered to secure a solid slab. Three such slabs, with the edges slightly rounded to allow slag or cinder to get away, are then piled together in the furnace, and re-heated to a welding temperature. Meanwhile, a porter bar properly prepared, is raised to a welding heat in another furnace. Shortly before drawing the three piled slabs from the furnace, the end of the porter bar is inserted into the space in the pile which has been prepared for it, as shown at *g*, and is tugged into the mass to make it adhere by welding. The whole is then drawn from the furnace, welded together under the steam hammer, and shaped to a bloom or "use" shown in thickness and breadth in the two views at C. Holes are punched, and pieces cut out hot as required, to bring the use to the shape shown at D. To accomplish this, the portion or "gusset," *h*, is just cut away with a large chisel or cutter under the hammer, the end roughly rounded up, and cut to length. Next, the portion, *i*, between the webs is cut out, and the middle roughly rounded up. A porter bar, *j*, is now clamped on the end, *k*, and the bar,

marked *l*, cut off. The use is then "turned end for end" to enable it to be brought to the form *E*, the corner, *m*, being removed by cutters, and the end rounded up and cut to length. To bring the crank webs at right angles, the middle portion between the webs is re-heated and twisted by means of a spanner, *n*, which is clamped to one web, *o*, the other web, *p*, being held between the anvil and the top of the hammer. Finally, the middle, which has been left large enough to allow for finishing after twisting, is hammered or swaged down to the required size, as suggested in dotted lines in the view *E*, to give the finished forging shown at *F*.

The method of forging a steel crank axle as carried out at Messrs. Taylor Bros.' works is essentially the same as above described for iron, except that the first two processes *A* and *B* for building up the bloom are omitted. In the case of steel, which is now in general use for crank axles, a solid ingot is cast, which is heated and broken down or roughed into a bloom of the form *C*, when the work proceeds exactly as before.

Steel Forgings are produced from ingots by a process of breaking down the solid block by means of sets and swages. The example of a marine engine connecting rod, Fig. 413 (*a*), is given to show the essential difference in the treatment of iron and steel. To make the forging in iron, slabs are welded on to a porter until a lump is obtained sufficiently large to form the forked end and a portion of the body of the rod as at (*b*). As previously explained, the forked end is forged solid, the piece shown in dotted lines being cut out by boring, slotting or milling, in the machine shop. The forked end is worked to shape by means of sets and swages, the body drawn down, and more slabs piled on the end to extend the rod, as at (*c*). This is continued to complete the butt end, the tapered form given to the body, the fork finished to dimensions, and the porter cut off, as at (*d*). It will be noticed that with wrought iron the process is one of continuous building up, and that the soundness of the forging depends largely upon perfect welding, which requires proper heating and good hammering. With steel, on the other hand, welding is avoided. Taking the same connecting rod as before, Fig. 413 (*a*), it will be seen that, commencing with the prismatic block, Fig. 413 (*e*), a portion for the fork is roughly forged at one end, leaving the remainder at right angles for the butt end as at (*f*). From this, by repeated

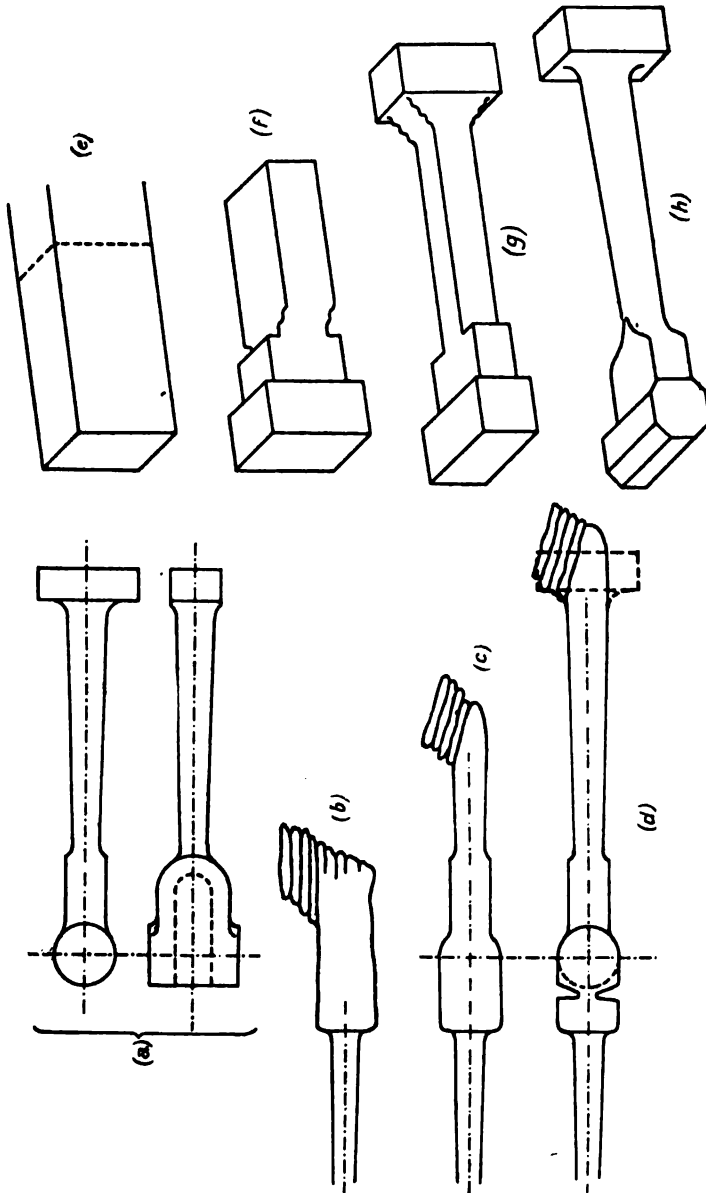

FIG. 413.—Connecting Rod Forgings in Iron and Steel.

setting down the butt is formed, and the body drawn out, as at (g). The forging is then finished by trimming off the corners to

M.T.

N N

form the boss of the fork, rounding the body by means of swages, and fullering out curves to the proper radius as seen at (h).

The photograph, Fig. 414, kindly supplied by Messrs B. & S. Massey, Ltd., of Manchester, shows a 3-ton Rigby type steam



FIG. 414.—Making Double-throw Crankshaft Forging.

hammer at work in a forge, rounding up the middle between the sweeps of a double throw crankshaft forging. It will be noticed that a weight has been clamped on one end to counterbalance the sweeps. The shaft is supported in such a manner as to permit of its being readily rotated under the hammer by means of an endless chain running round a pulley hanging from the crane.

CHAPTER XXXVI.

DROP FORGING OR STAMPING, FORGING MACHINES, ETC.

As already described, hand-made forgings are frequently finished in dies under the steam hammer, especially if a large number of the same article have to be made as nearly as possible of the same size and shape. This is in fact, only an extension of the method of forging in swages, of which the collar swage, Fig. 311(*f*), may be regarded as a typical example. A step further has led to the modern practice of stamping, in which a solid lump, with little or no previous treatment by hand, is squeezed between dies to the shape required with one or more blows from a drop hammer of the type shown in Figs. 319, 320, and 321, or of the special form of steam hammer, Fig. 341. Such "stampings" are extensively used for parts of rifles, sewing machines, bicycles, motor cars, etc., and when required in large quantities may be produced very cheaply, and with great accuracy, thus reducing machine work to a minimum. The dies are usually in pairs, one part secured to the tup, and the other to the anvil of the hammer; or the dies with the work between them may be placed on the anvil, and struck by the falling weight. In articles of from 2 to 4 feet in length, and for heavy forgings, the hydraulic press is employed, dead pressure being more penetrating than impact, as already explained. If only a comparatively small number of stampings are required, the dies may be made of good cast iron of massive dimensions, wrought iron or mild steel bands being shrunk round them to prevent fracture under the blows of the hammer. Cast iron dies are moulded from wood patterns in the ordinary way, and the surfaces are cleaned and polished by hand. They possess the advantage that when a pattern has once been made the dies may be replaced, in case of fracture, at very trifling cost. For the production of a large number of pieces, the dies are best made of forged steel case-hardened, or even of crucible cast tool steel, hardened on the face. The recesses in steel dies are cut out of solid as far as possible by milling or profiling, and are then finished by hand, using the chisel, file,

and scraper. "Die-sinking" is in fact, a highly-skilled trade to itself, requiring special training and experience, and steel dies are therefore very costly. The life of a steel die of average size



FIG. 415.—Set of Tools for Stamping Engineer's Spanners.

when working on mild steel, may be taken at from twenty to thirty thousand pieces.

Process of Stamping.—Articles of very simple form may sometimes be stamped and finished in one pair of dies, but in the majority of cases it is necessary to work in stages. The "stock"

or lump of metal, is, as a rule, subjected to a preliminary "breaking down" by the smith, bringing it roughly to the shape of the stamping. As a first operation, it may then be placed at a white heat in "edger" or roughing down dies, which are approximately of the form desired. With a few blows of the hammer, or strokes of the press, as the case may be, the top and bottom dies are brought as close together as possible. It will then be found that the surplus metal has been squeezed out between the dies forming a "fin" or "flash"—a feature inseparable from stamping. The second operation is to remove the fin in a matrix or "stripping die" in an adjacent hammer. Should the fin be very thick, the forging must be put back into the roughing out die, and the resulting fin again cut off. After one or two trials the stamper is easily able to avoid any undue excess of metal in the fin. For the third operation, all traces of the fin are removed, and the object brought down to exact size in finishing dies, which should leave the smooth and glossy surface characteristic of good work. The finishing dies must be made with an allowance for contraction, amounting on the average to $1\frac{1}{4}$ per cent. over and above the dimensions of the finished article. The method of procedure is clearly illustrated in Fig. 415, which shows a set of tools supplied by Messrs. B. & S. Massey, Ltd., of Manchester, for stamping engineer's spanners. The rough bar is seen on the left, and the different stages in the process are arranged in order, the finished stamping being shown on the extreme right. The dies and the work appear dark, the light-coloured blocks being used merely as supports in obtaining the photograph. In the case of small pieces, it is often possible to arrange the several sets of recesses for roughing down, cutting off, finishing, etc., in one and the same pair of dies. The stamping is sometimes liable to stick fast in the die, due to contraction in cooling, or perhaps on account of its shape. A hole is therefore made through the die in some convenient position, in which a bar may be inserted for knocking out the stamping.

Examples of Drop Forging.—A boss on one side of a lever may be formed in a single die, Fig. 416 (a), the flat surface of the ordinary top tool of the hammer or press doing duty as the upper die. In the same way, the T end of a small eccentric rod, or the foot of a pillar for a hand railing, Fig. 416 (b), may be dealt with. The loose piece shown at the bottom of the slot permits

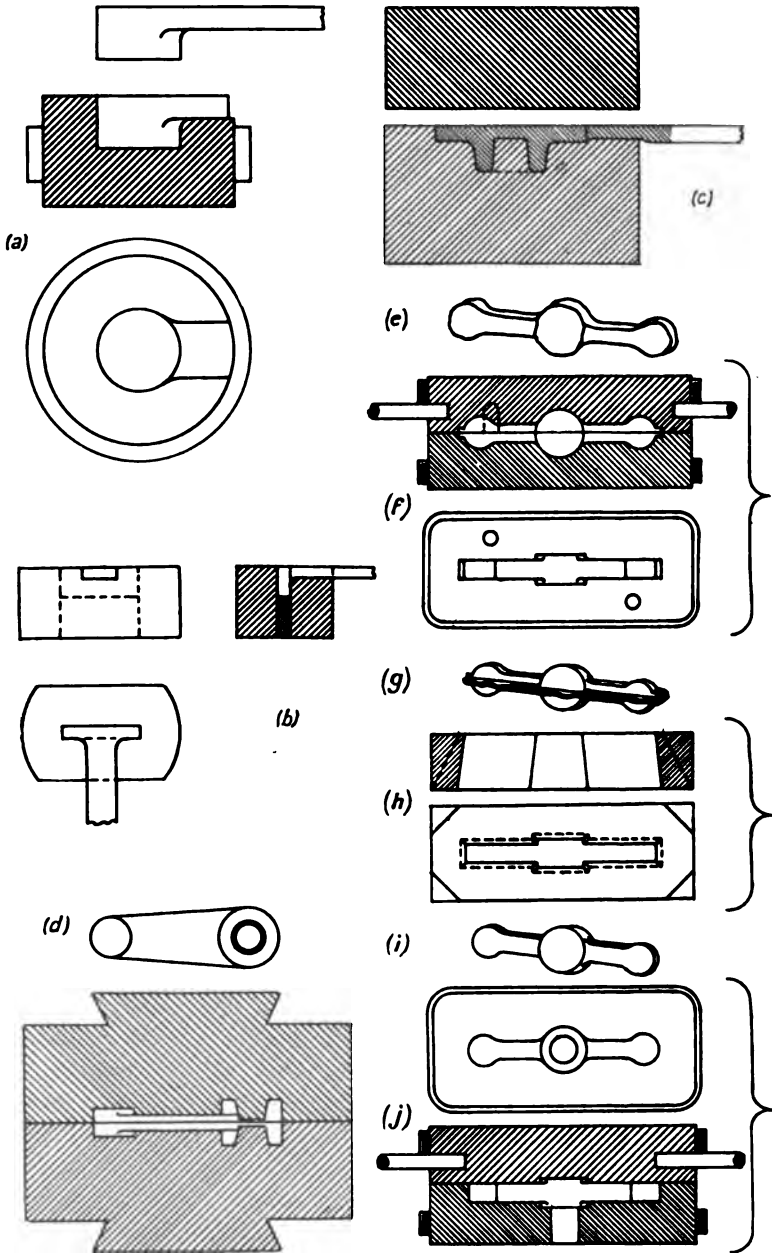

FIG. 416.

the ready removal of the stamping from the die. Circular flanges for wrought iron pipes are stamped from a round lump carried on the end of a porter bar, as shown in Fig. 416 (*c*). The hole in the boss is formed by a punch left solid in the lower die, but not coming quite through to the surface, to prevent one die actually striking the other when fracture would be very liable to take place. Fig. 416 (*d*) shows the dies for stamping a small lever, with punches for the hole in the boss almost meeting at the centre, thus leaving a fin which is easily removed when boring out the lever.

In many cases, drop forging or stamping is to be regarded simply as a finishing process, the object being to obtain uniformity in size and shape, and to reduce the amount of material "left on" for machining. It is, for instance, impossible

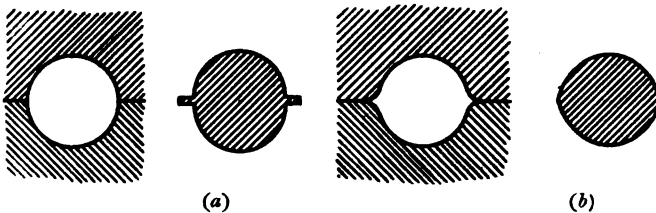

FIG. 417.—Shape of Dies to avoid Fin.

to produce from the square bar or lump in one pair of dies the two-armed lever shown at (*i*), Fig. 416. In the first place, the piece is forged very roughly to shape on the anvil by hand in the usual way, as at (*e*), and is then placed at a white heat in the roughing dies, (*f*). By means of a few blows in rapid succession, the dies are brought as close together as possible, leaving, however, a fin as at (*g*). This is removed from the still hot stamping in the stripping dies, (*h*), for which a separate hammer is usually provided. Should the fin be very thick, the piece is put through the roughing dies a second time, and the fin again cut off. Finally, all traces of the fin are removed, and the exact shape given in the finishing dies, (*j*), which are divided in such a manner that one of the faces of the centre boss is the only part which comes in the upper die. If a very large number were required, the piece shown, or even a more complicated part, might be produced without resorting to hand

work by employing a series of dies, each one approaching more nearly to the finished form.

To obtain a smooth polished surface, work of cylindrical form should be partially rotated after each blow during the roughing down process. If the dies are made as shown in Fig. 417 (a),

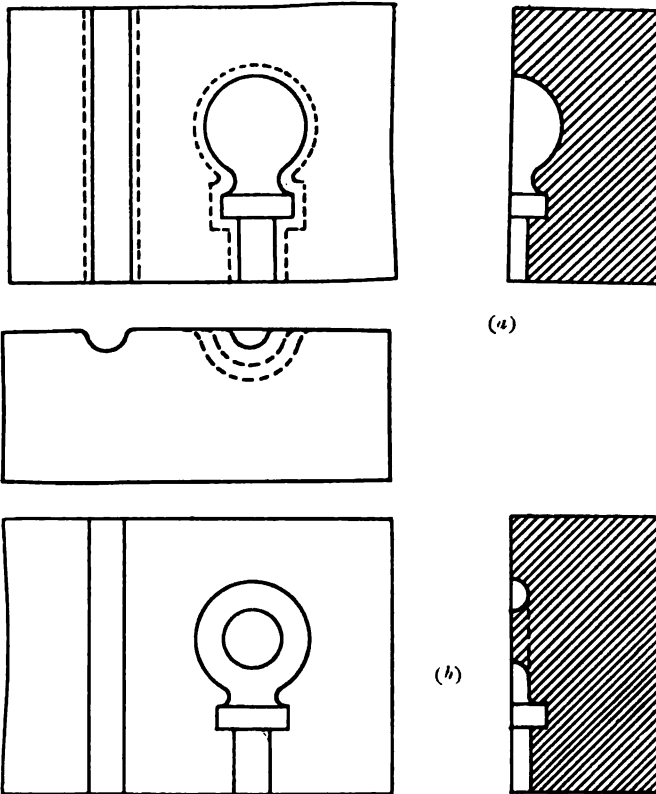

FIG. 418.—Roughing and Finishing Dies for Stamping an Eyebolt.

the fin produced by one blow will therefore be driven into the work by the next after the work has been given a quarter turn. The surface of the work will in this way be badly marked, and altogether unfit for machining. By making the dies with rounded edges, Fig. 417 (b), the fin is avoided, a slightly elliptical section being obtained instead. This may be rotated without fear of producing any unsoundness in the forging. When the

work cannot be rotated, some other means must be provided to permit the surplus metal to escape from the die. A channel termed the "flash," about $\frac{5}{8}$ or $\frac{3}{4}$ inch wide and from $\frac{1}{4}$ to $\frac{1}{2}$ inch deep, is frequently milled out of the face of the die round the outline of the recess, to contain the fin. This is afterwards cut off in the trimming or stripping die, an example of which is seen in Fig. 416 (*h*). The die simply contains a "gate," or hole of the same shape as the outline of the stamping, the hole tapering or clearing slightly towards the bottom. The die is shown cut away at the corners to take the "poppet screws" by which it is held on the anvil, in such a manner as to admit of exact adjustment. The stripping punch, corresponding to the upper die, is usually dovetailed to the top. The dies for stamping an eyebolt are shown in Fig. 418 (*a*) and (*b*). In the roughing down operation, a spherical or ball end with collar is forged on the rod, the amount of metal in the ball being just what is required to form the ring subsequently. It will be noticed from Fig. 418 (*a*) that one impression is provided to produce the ball end, the groove on the left serving for the shank, which may be of any length desired. The edges of both impressions are rounded off, as explained in Fig. 417 (*b*), so that by rotating the



FIG. 419.—Stamping Dies and Trimming Tools for producing Drawbar Hooks, Shackles, etc.

work through 90° between each blow of the hammer the formation of fin is avoided. In the finishing dies, Fig. 418 (b), the spherical lump is punched out and spread to form the ring or eye, and the shank brought to required dimension in a separate impression.

The illustration, Fig. 416, shows several sets of stamping dies and trimming tools supplied by Messrs. Massey, of Manchester, with one of their stamp batteries for producing draw-bar hooks, shackles, brackets, and other fittings. The roughing down, stripping, and finishing dies can be easily traced in each case.

Forging Machines.—Closely allied to the stamping hammer

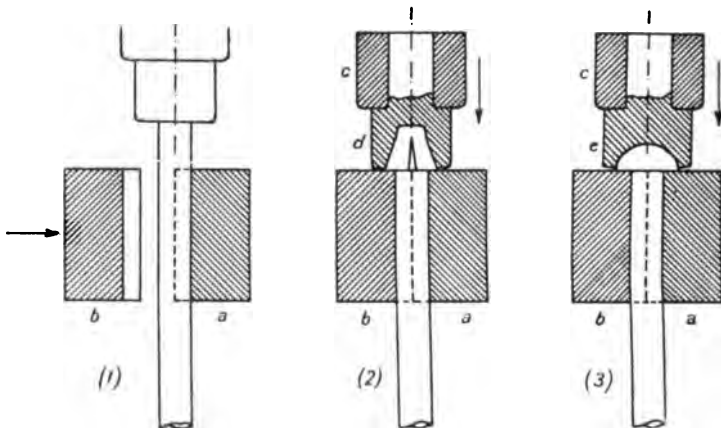

FIG. 420.—Principle of Nut and Bolt Forging Machine.

are two types of forging machine, operated mechanically by crank and connecting rod or toggle mechanism from a geared-down power-driven shaft. In stamping, it may be said that the process is almost invariably that of drawing down, but with the forging machine, although the work is produced in dies, the actual operation is limited to that of upsetting or jumping up by means of a power-driven ram. The first machine of this type was the *Horsfall Bolt and Nut Forging Machine*, originally introduced by Messrs. Greenwood and Batley, Ltd., of Leeds. The machine is intended for the manufacture of bolts, nuts, pins, spikes, rivets, and similar work which may be formed from a round bar. The principle of working is shown in Fig. 420. The work is gripped

between two side jaws, one of which, *a*, is fixed in position in the frame of the machine. The other jaw, *b*, is attached to a slide, to which a small movement is imparted by the machine, so that the two jaws are brought in contact with considerable pressure, once during each revolution. A rod of the proper size, the end of which has been heated in an adjacent furnace, is introduced through an outlet in the frame of the machine, and when the jaws open, is inserted between them, being pushed forward to project against a stop which has been adjusted to give the length of rod required to form the head by jumping up. The jaws close, (1), holding the rod firmly between them, and at the same time the stop is lifted automatically out of the way to allow a ram *c* to advance, upsetting the projecting end of the rod and forcing the metal into the cavity formed in the die carried by the ram,

(2). The change of shape from the round rod to the form of end required is frequently too great to be accomplished in one operation. In such a case, two or more dies may be carried by the ram, the first for roughing down to an intermediate form, and the second for finishing, (3), and it will generally be found possible to

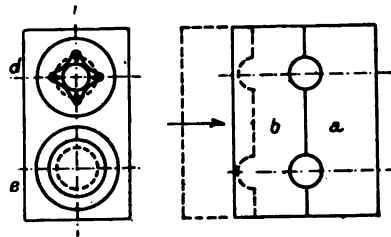

FIG. 421.—Gripping Jaws for Nut and Bolt Forging Machine.

pass from one to the other with successive strokes of the machine at one heat. Hence, the gripping jaws must be provided with two or more sets of grooves at different levels, corresponding to the dies in the ram, as in Fig. 421. The top header or "bunting" tool, *d*, acts first, breaking down the metal to form the head. The side jaws then open to allow the bar to be placed in the lower gripping dies, in which position it is again gripped, and the head finished by a blow from the lower tool, *e*. In the case of machines arranged for producing nuts, the ram carries also a punch. An important feature of the machine is the use of "side hammers," which not only enable better-formed work to be produced, but also permit a wider range of articles to be dealt with than is possible with header or bunter tools only. The side hammers are carried in separate slides, arranged alongside those for the gripping jaws, Fig. 422. The "bunt," as at *f*, is first

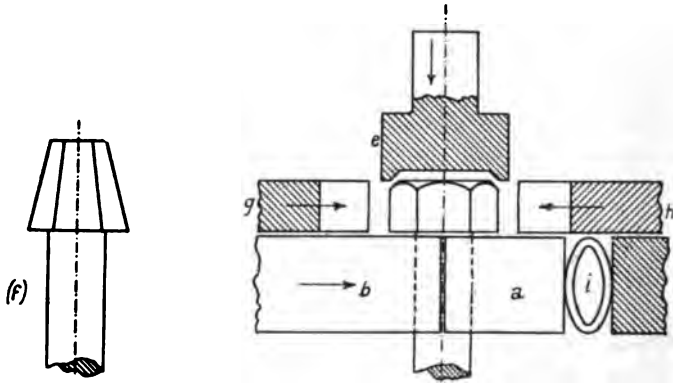

FIG. 422.—Use of "Side Hammers" for Nut and Bolt Forging Machine.

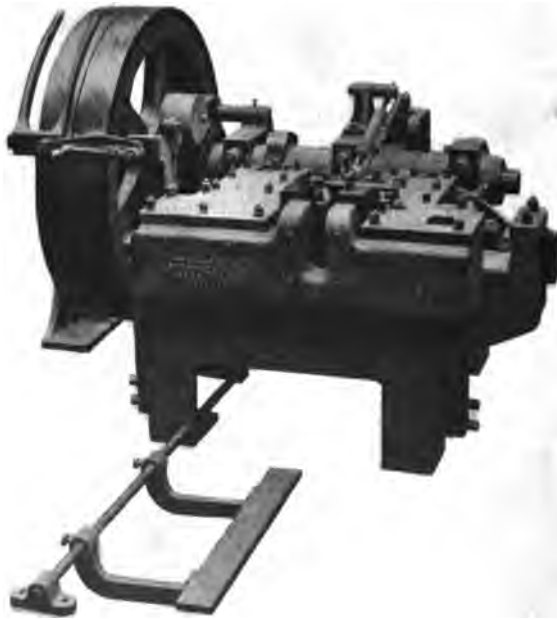

FIG. 423.—Horsfall Nut and Bolt Forging Machine.

produced as already explained. The work is then lowered into the second pair of gripping dies, *a* and *b*, and the second tool, *c*,

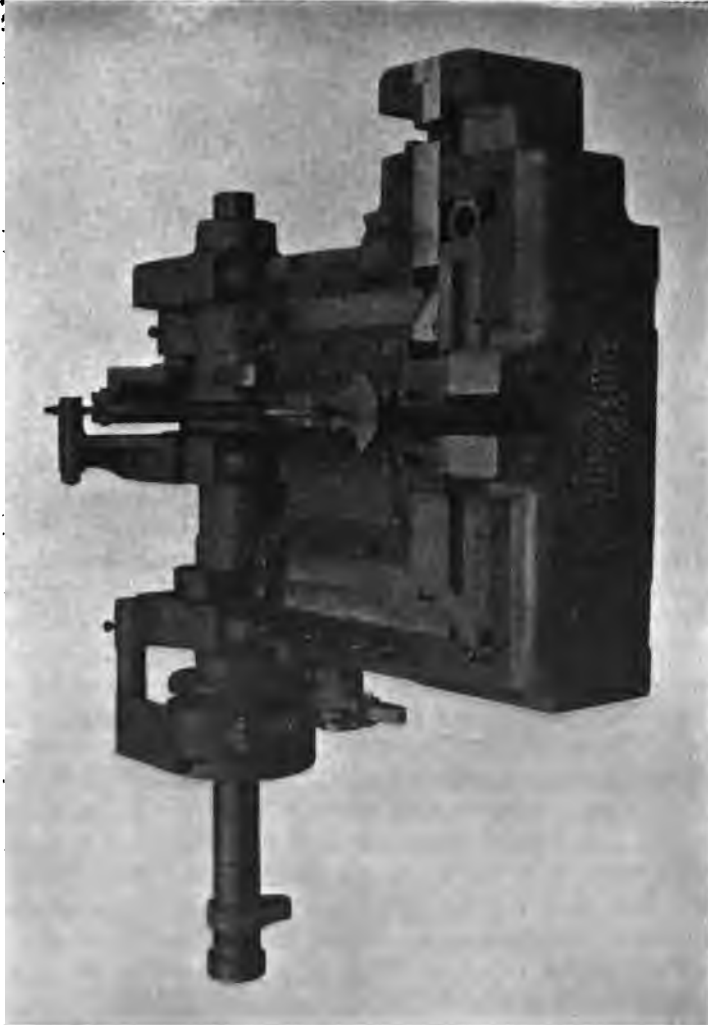
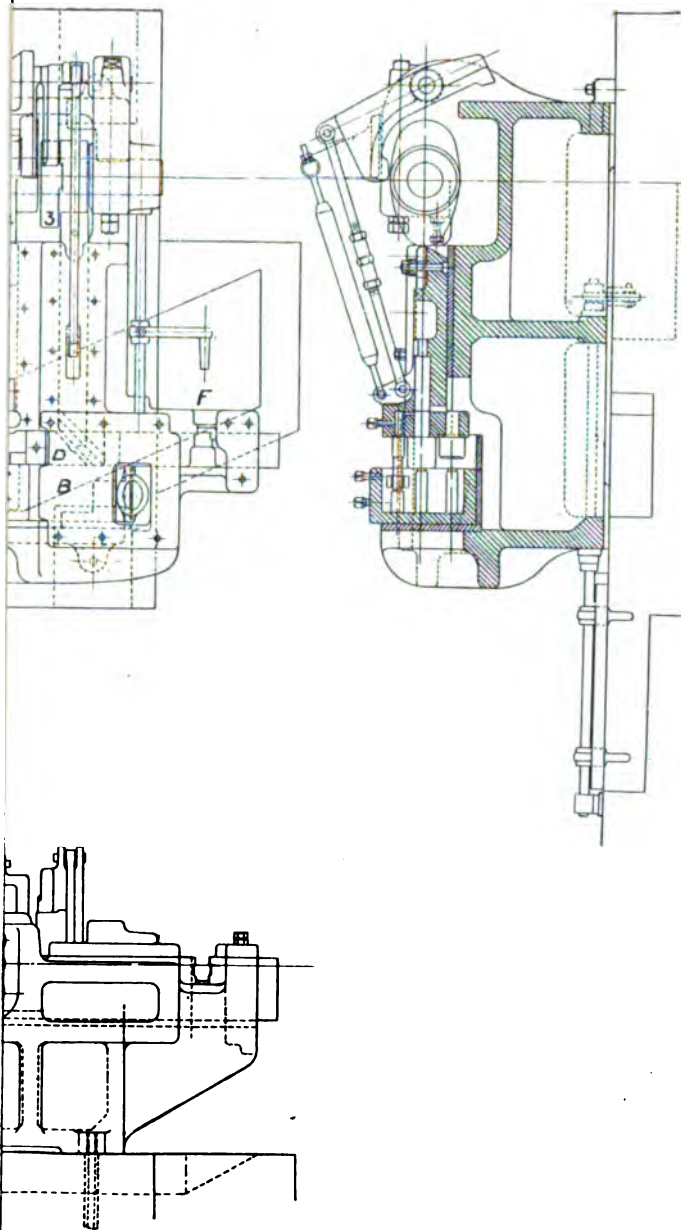

FIG. 424.—Nut and Bolt Forging Machine with Cover Plates removed to show Slides.

forms the work to the desired shape, while the side hammers, *g* and *h*, work the metal from the sides. To relieve the machine from any undue strain should the metal accidentally become jammed between the faces of the gripping dies, a cast iron

"safety breaker," *i*, is inserted between the frame and the fixed gripping die, *a*. This breaker is made sufficiently strong to withstand the normal working load, but to give way should any exceptional pressure come upon the machine. Fig. 423 is from a photograph of a machine capable of producing bolts, etc., up to $1\frac{1}{4}$ inches diameter. The same machine, with the cover plates removed to show the slides, is seen in Fig. 424. The drive is by means of fast and loose fly-wheel pulleys on the cam shaft, which is carried in bearings at the back of the main frame. Motion is transmitted to the cam shaft by a special type of clutch which allows the cam shaft to make one complete revolution and stop with the dies wide open, or to run continuously as desired. The clutch is operated by the treadle at the front of the machine. The guides for the closing die, side hammer, and header slides, are formed in the bed, as seen in Fig. 424. The cams, which are of chilled cast iron keyed on the cam shaft, bear against hardened steel thrust pieces on the ends of the intermediate slides or rams. These are provided with inclined or wedge-shaped ends, which operate the transversely moving slides carrying the closing dies and side hammers respectively. The safety breaker inserted between the frame and the end of the fixed closing die slide, is seen on the right. When the work has been completely formed, it is cut off at the same heat by a pair of shear blades, one carried rigidly on the main frame, and the other on the end of the right-hand side hammer slide, an adjustable gauge being provided to give any desired length. A drawing of a larger machine, having a capacity up to $2\frac{1}{4}$ inches diameter, is given in Fig. 425. Here the drive is through double-helical reduction gearing, the larger wheel of which is connected to the cam shaft by the clutch as before. A is the header slide, fitted with bunting and finishing dies and punch. B and C are the closing slides, acting transversely, and carrying the gripping dies for holding the bar. D and E are the side hammer slides, also moving transversely, the latter carrying the shear blade, F. The cross section shows clearly the arrangement of the heading tool, and the method of imparting motion to the slides. Two cams are required for each slide, giving the forward and return strokes respectively. For the forward motion, the cam bears directly against a hardened steel plate on the end of the slide. To effect the return stroke, the corresponding cam actuates a lever which is mounted on the



Forging Machine for 2 1/4 inch diameter.

[To face p. 558.

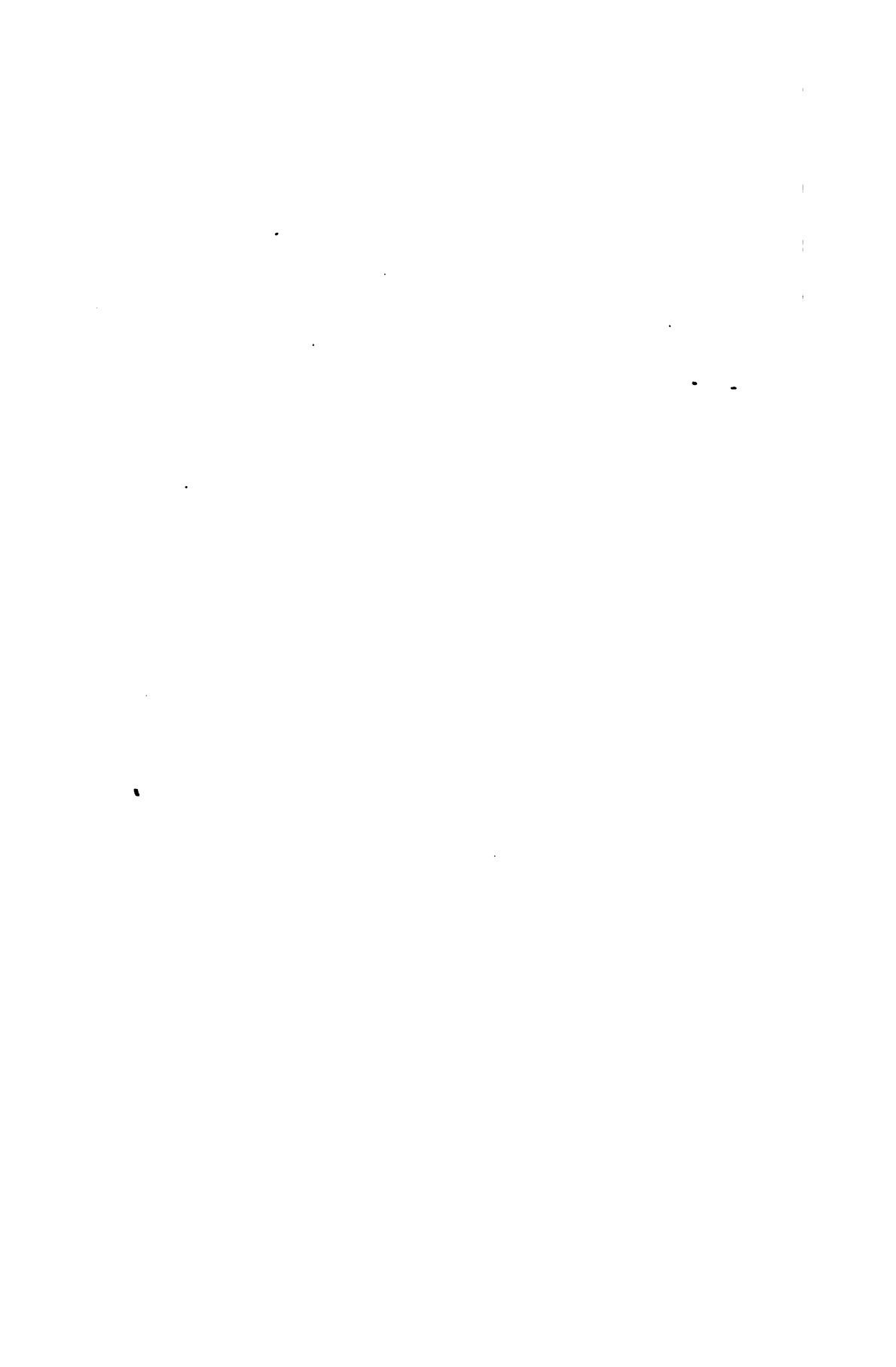



FIG. 426.—Typical Examples of Work done by Forging Machine.

main frame of the machine, and which, by means of a connecting rod, is coupled to the slide. A strong helical spring, inserted between a fixed bracket and the slide, serves to maintain the parts in contact. A similar spring at the front of the machine serves the same purpose for the transverse slides. In addition to bolts, nuts, and rivets of all kinds, typical examples of work done by the Horsfall machines are shown in Fig. 426. Machines of this

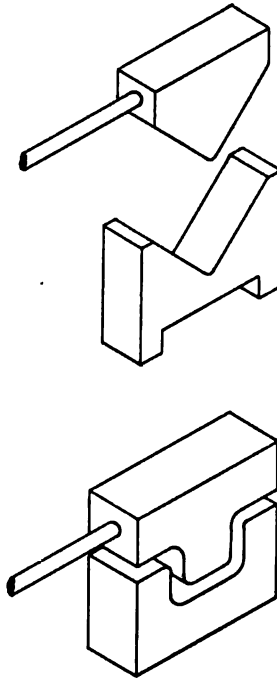

FIG. 427.—Cast Iron Blocks for Bending Brackets.

type are capable of being worked at from 25 or 30, up to 60 or 80 strokes per minute, according to size.

The second variety of forging machine, the *bending press*, or "Bull-dozer," as it is termed in America, is mainly employed for work which can be produced by bending, although available to some extent for use with dies. A simple form of block for bending a double corner has already been noticed, Fig. 347. Another example of the use of cast iron blocks for bending a bracket from flat bar under the steam hammer is shown in Fig. 427. Much

of the smithwork for railway waggons is of this character, and many other instances can be found where such pieces are required in large quantities. For this purpose the bending press, Fig. 428, is admirably adapted. A slide or ram, driven by crank and

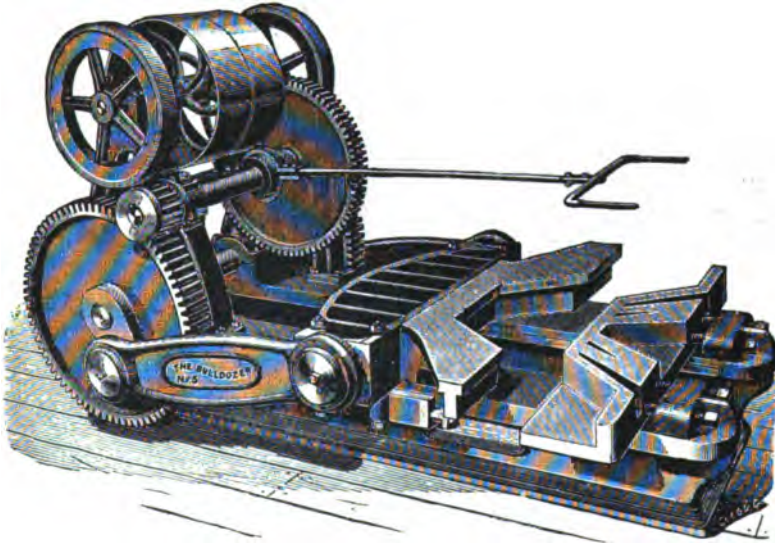

FIG. 428.—Bending Press.

connecting rod mechanism from a double-gearred shaft, and having a constant stroke, may, by using suitable distance pieces and packing, be caused to exert the pressure necessary for squeezing into shape between cast iron blocks articles of any simple form.

CHAPTER XXXVII.

PRODUCTION OF PARTS BY ROLLING.

The Rolling Mill.—Wrought iron or mild steel may be reduced to the form of bars or plates much more rapidly and cheaply, and at the same time more exactly uniform in section, by rolling than by forging under the hammer or the press. Hence, plates and bars of flat, round, angle, tee, channel, girder, etc., section, and

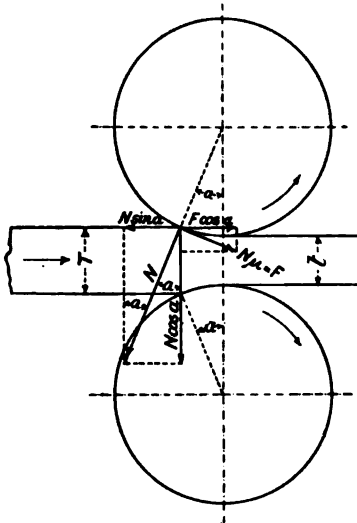

FIG. 429.—Action of Rolls in Rolling.

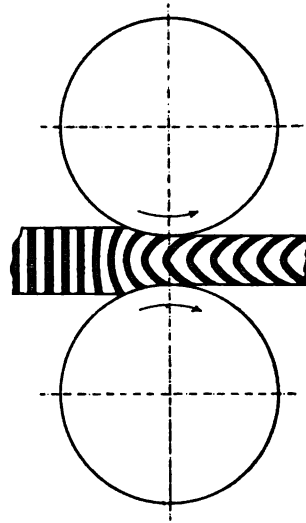

FIG. 430.—Flow of Metal in Rolling.

rails for tramways and railways, are invariably produced by rolling.

A *Rolling Mill* usually consists of two cast iron rolls, the axes of which are placed horizontally one immediately above the other, and are capable of revolving in opposite directions. The work on being caused to enter the rolls is thus carried forward by friction, and the centres of the rolls being maintained at the proper

distance apart, some reduction in thickness takes place, accompanied by a corresponding increase in length, the width being only slightly affected. In order that the work may be seized and carried forward by the rolls, certain conditions, Fig. 429, must hold good. At the point of contact of the original thickness T of the piece with the rolls, the normal reaction N may be taken to act. The friction F between the work and the rolls is then $= N\mu$, where μ = coefficient of friction for the given conditions. If now the forces N and F are resolved into their horizontal and vertical components $N \sin \alpha$ and $N \cos \alpha$ on the one hand, and $F \cos \alpha$ and $F \sin \alpha$ on the other, then it will be seen that the component $F \cos \alpha$ tends to draw the work between the rolls, whereas the component $N \sin \alpha$ acts in the opposite direction. Therefore

$$\begin{aligned} F \cos \alpha &> N \sin \alpha, \\ \text{or, } \mu N \cos \alpha &> N \sin \alpha, \\ \text{or, } \mu &> \frac{\sin \alpha}{\cos \alpha} = \mu > \tan \alpha. \end{aligned}$$

Calling φ = angle of friction, then, as is well known, $\mu = \tan \varphi$, and we have

$$\tan \varphi > \tan \alpha, \text{ or } \varphi > \alpha.$$

That is, the angle α must be less than the angle of friction, if the work is to be carried forward between the rolls. The angle α diminishes with an increase in the radius of the rolls, and with the difference between the thickness of the work and the distance between the rolls, or in other words, with the reduction in the thickness of the work due to rolling, $= T - t$. The ability of the rolls to seize the work therefore increases with the diameter of the rolls, and with diminution of the reduction in thickness due to rolling. With one passage through the rolls, only a comparatively small reduction in thickness can therefore take place. The work is consequently caused to make a number of passes through the rolls, at each of which the rolls are brought nearer together if plates are being rolled, or grooves of different shapes and depth are used when rolling bars or sections.

The "flow" of the metal, as it is termed, which takes place in rolling is shown in Fig. 430, from which it will be seen that the material on the outer surfaces which come in contact with the rolls is pushed forward, leaving the inner layers behind. The action to which the material is subjected is well shown in Fig. 431,

which represents the results of some experiments by Polak of Prague, carried out upon a mass of china clay arranged in vertical layers of different colours. The outer layers in contact with the rolls are carried forward on account of the friction due to the pressure of the rolls upon the work. In consequence, the material in the interior is not only subjected to pressure, but is also put in tension to some extent, and its motion is retarded. The extreme end of the piece being rolled, on the right of the figure, was first seized on entering the rolls, and it is only at the fifth vertical layer from the right that the true action of rolling commences. The top and bottom of the vertical lines to the left of the rolls are caused to slope more and more towards the right until the full reduction in thickness has occurred, the material

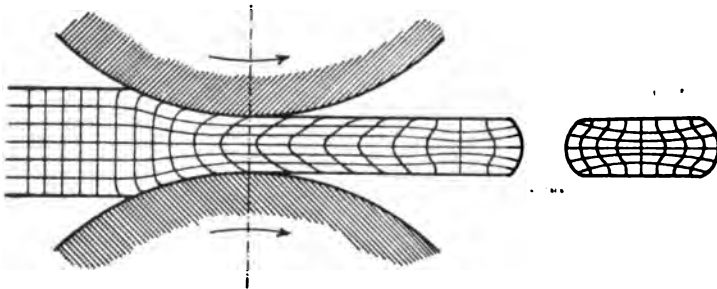

FIG. 431.—Action of Plastic Material in Rolling.

on the exterior being pushed forward. At the same time, the distance apart of the vertical lines increases as they are bent, the horizontal lines being brought closer together. The velocity of the bar as it leaves the rolls is somewhat greater than the circumferential velocity of the rolls, due to the stretching of the outer layers. The action is a somewhat complicated one, of which no satisfactory theory has yet been proposed.

A *Train of Rolls* is shown diagrammatically in Fig. 432. It consists of three sets of " housings," hh , h_1h_1 , and h_2h_2 , to contain respectively the driving pinions, gg , usually of double-helical pattern, the roughing rolls, r_1r_1 , and the finishing rolls, r_2r_2 , which may be arranged either "two-high," Fig. 432, or in some instances, "three-high," Fig. 433. In either case, the pinions, gg , are driven through the shaft, a , from a powerful steam engine or electric motor, of which the flywheel, f , is carried in bearings, bb ,

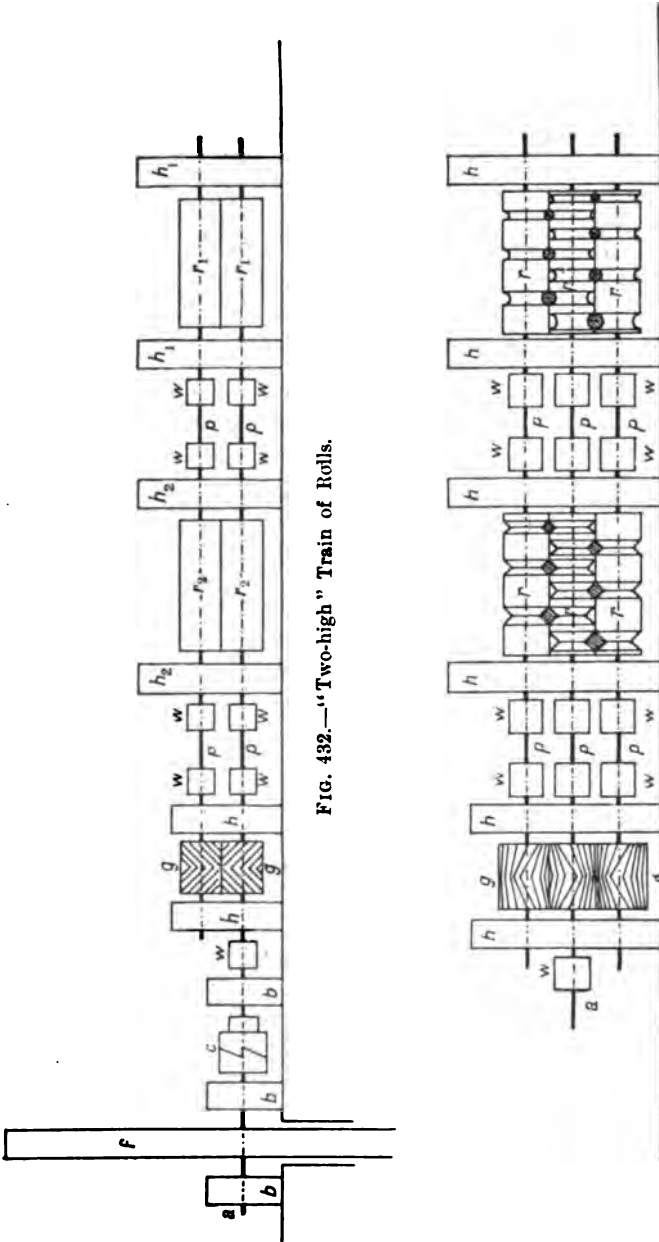

FIG. 432.—“Two-high” Train of Rolls.

FIG. 433.—“Three-high” Train of Rolls.

a coupling, *c*, being provided to detach the train in case of emergency. In this way power is transmitted through the pinions to the upper rolls, the bearings of which are capable of adjustment in a vertical direction by means of screws, whilst the lower rolls run in fixed bearings. The connection between the pinions and the roughing rolls, and again between the roughing and the finishing

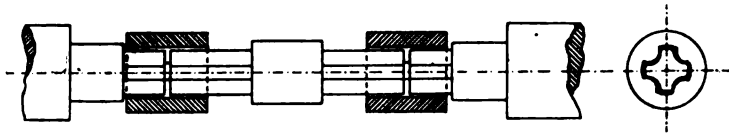

FIG. 434.—Breaking Pieces and Wobblers.

rolls, is made by means of "breaking pieces," *pp*, and coupling boxes or "wobblers," *ww*, the latter fitting loosely over the star-shaped ends of the rolls and spindles, Fig. 434, and thus permitting the distance apart of the centres of the rolls to be altered slightly as required. The breaking pieces, *pp*, are purposely made just strong enough to transmit the maximum power required to drive the rolls, so that should any greater resistance

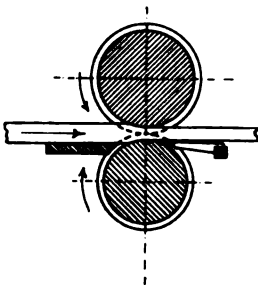

FIG. 435.—"Two-high" Rolls with Stripping Plate.

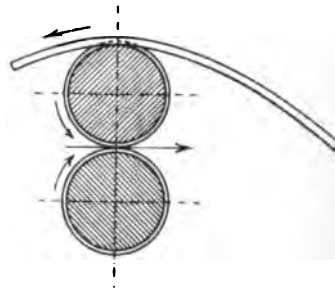

FIG. 436.—"Two-high" Rolling Mill.

due, say, to sticking of the plate or bar, be encountered, the spindle will be broken instead of the much more costly roll. The latter consists of a central portion, Fig. 439, with a projecting piece at each end, part of which is turned up to form the journal, and the remainder shaped as described above to take the wobbler. The central portion of the roll is perfectly smooth and cylindrical in the case of a plate mill, but has a series of grooves turned in it, when designed for rolling bars, rails, etc. The length of

the central portion should not exceed from $2\frac{1}{2}$ to $3\frac{1}{2}$ times the diameter.

“Three-High” Rolls.—The disadvantage of the “two-high” rolling mill, Fig. 432, is that after each pass the work must be returned again to the front side before rolling can be continued. This is most easily effected by placing the bar on the top of the upper roll, by which, as seen from Fig. 436, it is carried back in the reverse direction. The loss of time and consequent cooling of the work which occurs in this way is entirely avoided with the “three-high” arrangement, Fig. 437, which enables rolling to be performed in both directions, as shown.

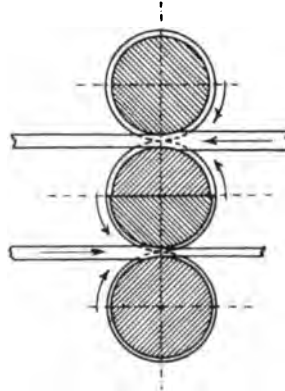

FIG. 437.—“Three-high” Rolling Mill.

Reversing Rolling Mill.—With “three-high” rolls the work requires to be raised on one side of the rolls, and lowered on the other, to enter the proper groove for the next pass. For light work this is of little consequence, but boiler plates of large area, and heavy sections, such as armour plates, etc., can only be raised and lowered by mechanical means. This may be avoided, and the cost of one

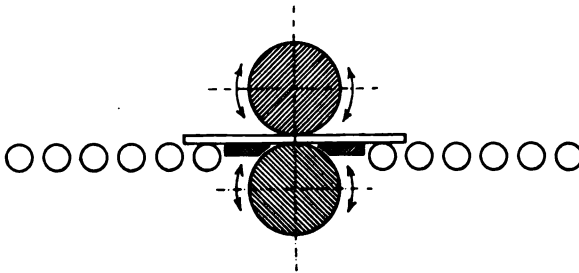

FIG. 438.—Reversing Rolling Mill.

of the heavy and expensive rolls saved, by the method of reversing the engine which drives the rolls after each pass, Fig. 438. The reversing rolling mill was first introduced by the late Mr. John Ramsbottom, formerly chief engineer of the L. & N. W. R. Co.'s works at Crewe.

The sketch also shows the "live rollers" for bringing the work to the rolls. These are all driven by bevel gear from the

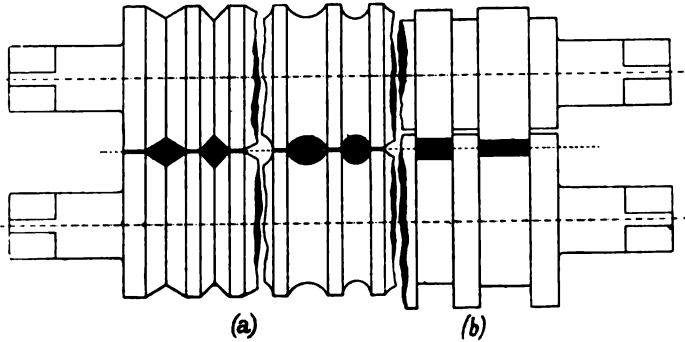

FIG. 439.—Form of Grooves in Rolls.

same shaft, which is operated by a steam engine or electric motor, and is capable of being started or reversed, as the direction of rolling may require. Live rollers are always employed in steel

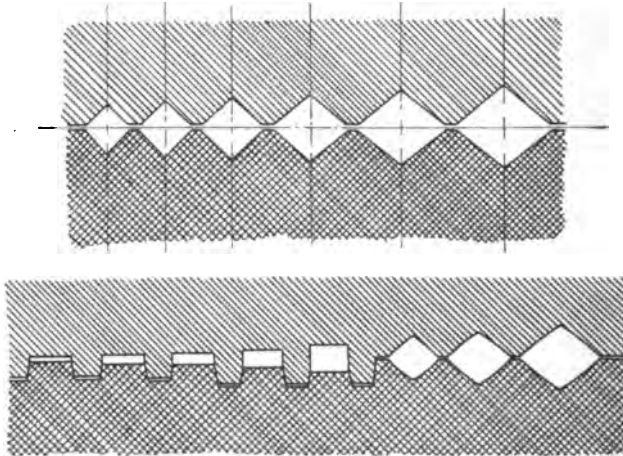

FIG. 440.—Section of Grooves for Square and Flat Bars.

mills, on account of the great weight of the ingots and slabs to be dealt with.

Form of Grooves in Rolls.—Two different types of groove are in use, known respectively as *open* and *closed*. The former, shown

at (a), Fig. 439, is only employed for round and square sections, whilst flat bar, Figs. 439 (b) and 441, joists, rails, etc., Figs. 443

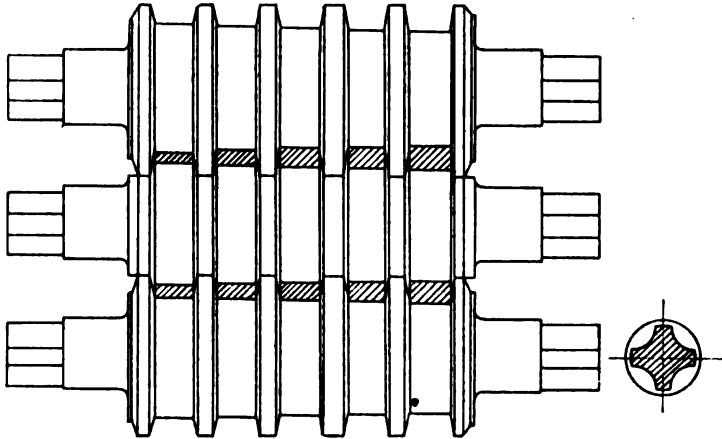

FIG. 441.—Three High Rolls for Flat Sections.

and 445, must be rolled in closed grooves. As closed grooves cannot be used for plates, the edges cannot be rolled true, but

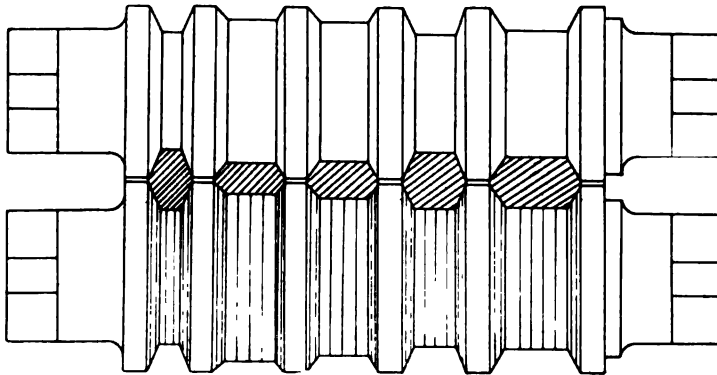

FIG. 442.—Series of Grooves for Rolling down Square Bar.

must be sheared straight when cold. The rough ends of bars and rails are cut straight or "cropped" immediately after rolling and whilst still hot, with a circular saw.

It is intended that the pressure of the rolls upon the work

should come in a vertical direction only, in order to bring about the desired reduction in thickness. Some little increase in breadth must, however, take place, and it therefore follows that the work must never be wider than the groove which it is to enter. To allow for this, the work, after each pass, is turned through an angle of 90° before entering the next groove, and in a series of grooves for rolling down, say, round or square bar, the height of each groove is made somewhat less than the breadth, and the breadth rather more than the height of the preceding groove, as seen in Figs. 440 and 442. By turning the work through a right

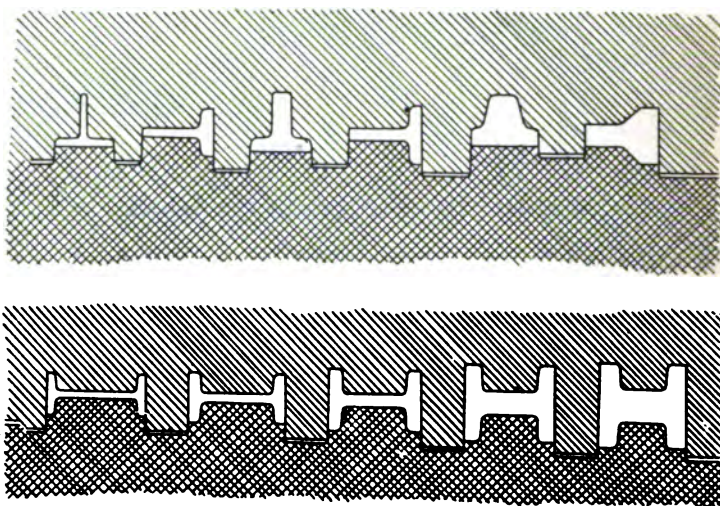

FIG. 443.—Sequence of Grooves for Rolling T and Girder Sections.

angle at each pass, the action of rolling in consolidating the metal is felt in all directions, the work done in this way having an important influence on the quality of the product. The last groove in any series must, of course, possess the exact form of the section of the finished article. It might be pointed out that in Fig. 439 are shown portions of three separate rolls, each of which would, of course, contain a series of grooves for one form of section only. The sequence of grooves for rolling out tee and girder sections is given in Fig. 443, and it will be noticed that the above considerations apply in this case also.

It is, of course, necessary to roll out the given section from the

pile to the finished size in one heat, and it is therefore desirable to reduce the number of passes and consequently the number of grooves in the rolls to a minimum, the number and cost of the

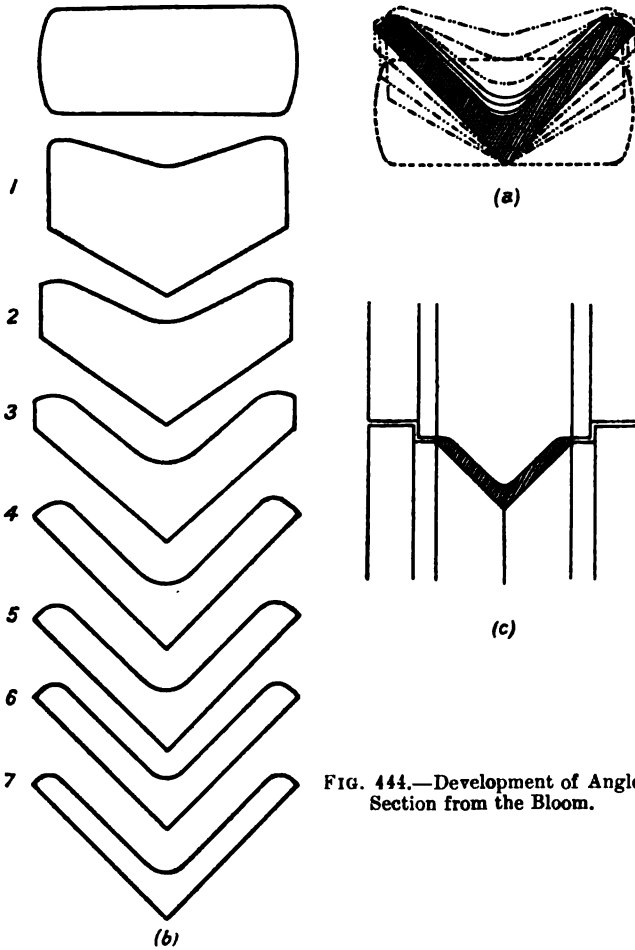

FIG. 444.—Development of Angle Section from the Bloom.

rolls themselves being at the same time kept as low as possible. The design of the grooves of the proper shape to effect this object is a difficult matter, requiring considerable experience. In Fig. 444 (a), is shown the development of an angle iron from the bloom, which is brought down to the finished section in seven passes,

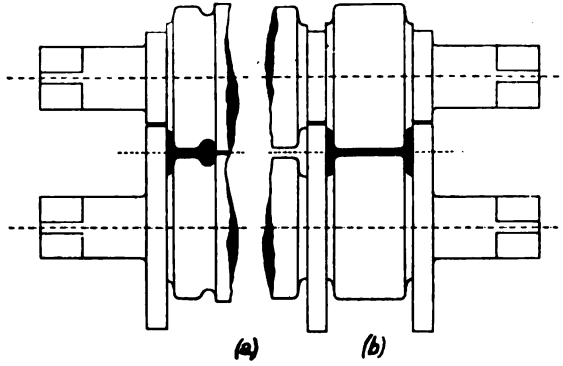

FIG. 445.—Rolls for Flange Rails and Girder Sections.

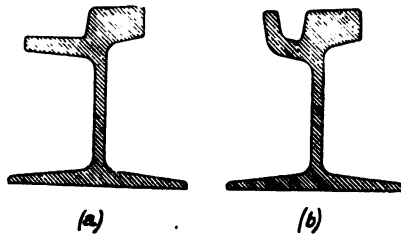

FIG. 446.—Tram Rail Section.

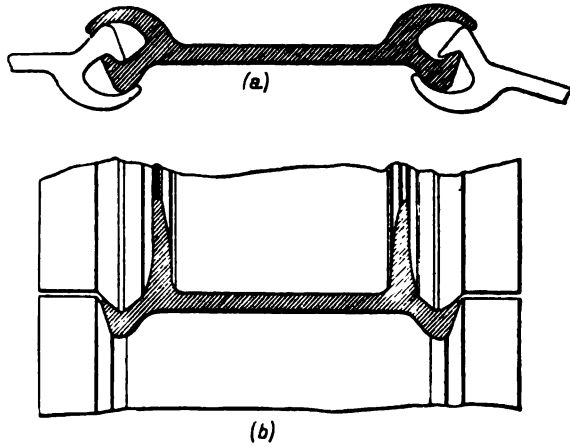

FIG. 447.—Rolling Steel Sheet Piling.

Fig. 444 (b), the grooves in the rolls being formed as in Fig. 444 (c).

Flanged rails and girder sections are rolled in closed grooves, Fig.

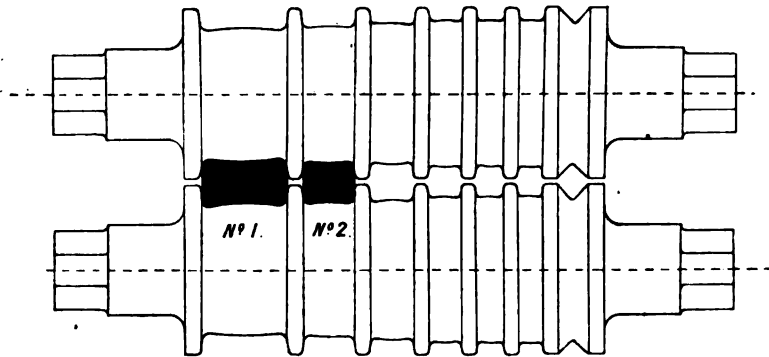

FIG. 448.—Cogging Rolls for Tram Rail.

445 (a) and (b), respectively, seven or eight passes being required to bring down the prismatic block or ingot to the finished form. Certain sections, some portion of which is undercut, may sometimes

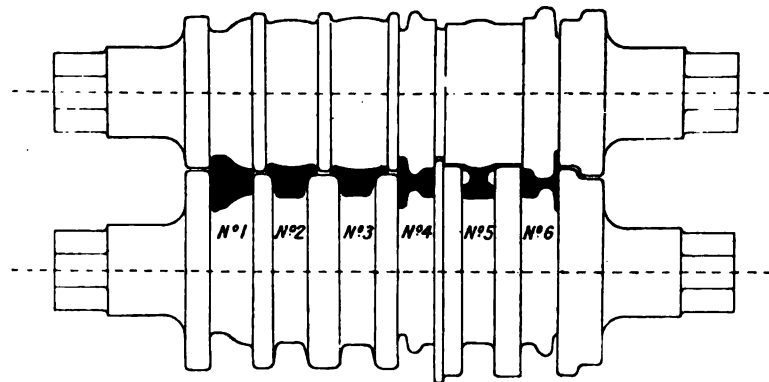

FIG. 449.—Roughing Rolls for Tram Rail.

be dealt with in two distinct operations. Formerly, grooved rails for tramways, etc., were first rolled to the form shown at (a) in Fig. 446, the lip being afterwards bent into proper position to form the groove as at (b), by means of special rolls operating laterally. This method is still pursued in producing the inter-

locking steel sheet-piling shown in section at (a), Fig. 447, the form of the rolls for which is seen immediately below at (b). The lip is bent over subsequently in a second set of rolls. For tram rails, however, this method was abandoned some years ago in favour of the present practice of forming the groove by means of auxiliary vertical rolls. By the courtesy of Messrs. Walter Scott, Ltd., Leeds Steel Works, the author is enabled to reproduce drawings,

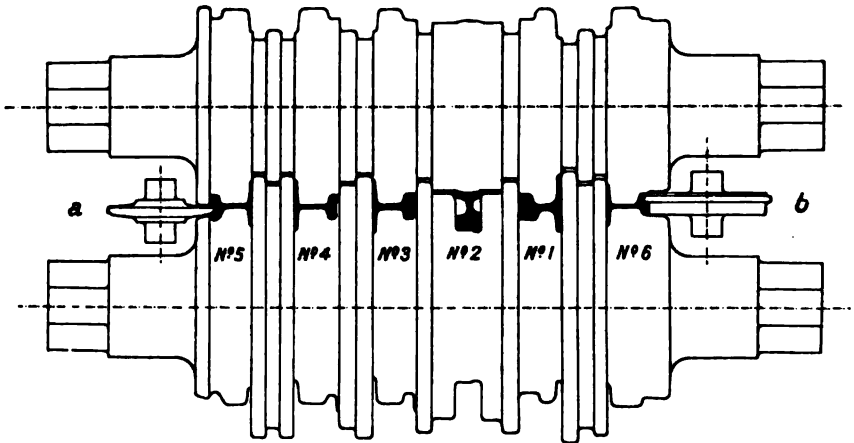

FIG. 450.—Finishing Rolls for Tram Rail.

Figs. 448, 449, and 450, showing respectively the cogging, roughing, and finishing rolls for the British Standard No. 4 tram rail. It will be noticed (Fig. 450) that during four passes, working from right to left, the head of the rail is formed solid. At the fifth pass on the extreme left, the auxiliary vertical roll *a* comes into action, roughing out the groove. At the sixth and last pass on the extreme right, the section of the rail is brought down to size, and the groove finished by the second auxiliary roll *b*.

CHAPTER XXXVIII.

WIRE-DRAWING, AND WIRE-DRAWING MACHINERY.

Wire-drawing.—The smallest size of round iron or steel “rod” which can be economically produced by rolling has a diameter of about $\frac{3}{16}$ inch. The small rolling mill employed for this purpose runs at a very high speed, and the wire passes continuously through five or six grooves in succession with a velocity of about 20 feet per second. After each pass, the wire is returned to the rolls round a semicircular path or large loop (hence the term “looping mill”), at the centre of which the workman stands in a small sheet iron enclosure, as a protection against possible injury should the loop be drawn in rapidly, due to one part sticking in the rolls. All ordinary sizes of wire, which are specified, not in terms of the diameter, but by numbers of what are known as the Birmingham and Standard Wire Gauge (B. W. G. or S. W. G., as the case may be), are produced by “drawing down” from the smallest size which can be rolled. In this operation the thick wire, or rod of small diameter, is pulled through a die having a conical hole somewhat smaller than the rod, a reduction in diameter, and consequent increase in length, taking place, Fig. 451 (a). The drawing is conducted in the cold state, or with the metal at ordinary temperatures, and this confers the great advantage that the wire may be drawn bright,

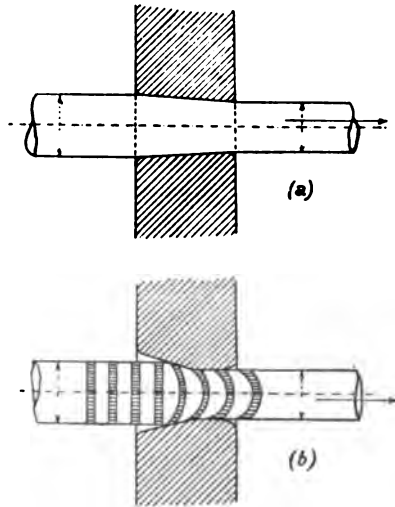

FIG. 451.—Draw Plate and Action in Drawing.

subsequent polishing being unnecessary. The mechanical work expended in bringing about a given result is enormously greater in the case of drawing than with rolling, and hence the former operation is practically confined to the production of rods or wire which, on account of smallness in size, would cool so rapidly that rolling would be impossible. Wire-drawing, too, results in a change in size only, the shape of the section remaining unaltered, whereas in rolling, the reduction which occurs is mainly in thickness, some change in the form of section being inevitable. In drawing, the form of cross section is not, however, limited to round, square, or hexagonal, and complicated outlines, such, for instance, as the pinion wire of the clockmaker, may be readily produced. Due to friction in passing through the die under considerable pressure, the outer surface of the wire is retarded and left behind as compared with the material in the centre, stretching thus taking place in the opposite direction to that which occurs in rolling. If the material before drawing be regarded as composed of a number of discs, the action of drawing is to pull out the discs into the form of hollow cones, fitting one inside the other, Fig. 451 (*b*). This explains the defect known as "cupped wire," which often occurs in a pronounced form in cold-drawn bars of about $\frac{1}{2}$ inch in diameter. The defect is probably due to the use of hard or unsuitable material, which in passing through the die shows a constant tendency to the cup and cone fracture suggested in Fig. 451 (*b*). The amount of drawing down which can take place at one operation is comparatively small, and a rule frequently used is to make the ratio of the diameters before and after drawing as 10 : 9. Calling d and d_1 , the diameters in inches of the wire before and after drawing, then the ratio of drawing down $= r = \frac{d_1}{d}$ may be taken = .9 for iron, .925 for copper, and .95 for steel. The force P , in pounds, which has to be exerted in pulling the wire through the die is proportional to (1) the reduction in area which takes place; (2) to the hardness of the material, which may be expressed as a constant h ; and (3) to the friction in the die, which may be represented by the coefficient f . Then

$$P = \pi \frac{d^2 - d_1^2}{4} (h + f).$$

The tensile strength of the reduced end must, of course, exceed

the total resistance due to drawing down, or if t = safe tensile strength of the material in pounds per square inch,

$$\pi \frac{d_1^2}{4} t > \pi \frac{d^2 - d_1^2}{4} (h + f).$$

From which the maximum value of the ratio of drawing down may be deduced

$$r = \frac{d_1}{d} = \sqrt{\left(\frac{h + f}{h + f + t}\right)}.$$

To reduce the coefficient of friction, f , and diminish wear of the die as far as possible, the wire is passed through some lubricating substance just before entering the die, for which purpose oil, tallow, wax, soap, stale beer, etc., are employed.

Annealing.—As shown above, the reduction in diameter proceeds very slowly, and the wire must be drawn through a series of holes of gradually diminishing diameter to reach any given size. By repeated drawing, the ultimate strength of the wire is greatly increased, the structure of the metal becoming closer and stringy, but the ductility is diminished almost in the same ratio, and in this condition the wire is known as “hard drawn.” Before drawing can be continued, such wire must be annealed, to restore ductility, although with some loss of ultimate strength. Drawn wire, even when annealed, has always a much higher strength per square inch than that of the rod from which it was produced. As an example of drawing down, it may be taken that to reduce iron wire from $\frac{1}{4}$ to $\frac{1}{8}$ inch in diameter, requires the passage through twelve holes in the draw plate, with three times annealing during the whole process. It is of great importance that the wire should be thoroughly and uniformly annealed, and as far as possible out of contact with the air. This is effected in gas-fired ovens, the coils of wire being placed in cylindrical pots with covers luted on, gradually raised to a red heat, and then allowed to cool slowly. In the case of steel wire, great care must be taken to avoid overheating and burning the steel. The thin film of oxide with which the wire is covered during annealing, is removed by friction with sand in a revolving drum, or by pickling with very dilute sulphuric acid, and subsequent washing.

Formerly, it was considered necessary to anneal copper in similar stages to steel wire, but the modern practice is not to

anneal copper until drawn down to the size in which it is required for use.

Speed of Drawing.—The velocity of drawing is a matter of great importance, and is limited mainly by the heat due to friction in passing through the die, but allowance must also be made for the fact that a certain time is occupied by the molecules in changing their positions. As a general rule for any given material, it may be said that the finer the wire the higher the speed of drawing. The following table represents average practice for three common sizes of wire :—

Size of Wire, diam. in inches.	Speed of drawing in feet per minute.		
	Steel.	Iron and Brass.	Copper and Silver.
$\frac{1}{4}$	300	350	400
$\frac{3}{8}$	500	600	700
$\frac{1}{2}$	800	1,000	1,200

Drawing Plates and Dies.—The manufacture of accurate and durable drawing plates is attended with considerable difficulty. For thick and medium sizes of wire, they are usually made of unhardened crucible cast tool steel, of high carbon content. It is unfortunately impossible to resort to hardening, for two reasons. As is well known, some change in shape and size almost invariably occurs in the hardening process, and in the second place, whenever an appreciable amount of wear has taken place, it is necessary to be able to restore the hole to its original diameter with as little trouble as possible. "Breaking down," or "ripping" dies are usually made in the form of a small slab, termed a "wottle plate," about 12 inches \times 2 inches \times $1\frac{1}{2}$ inches in size, large enough to contain from 6 to 12 holes, Fig. 452. The dies employed for finishing are generally either round or square about $1\frac{1}{2}$ inches diameter by 1 inch thick, and have one hole only, Fig. 453 (a). The countersink is formed by drilling, but the bearing hole is punched approximately to size, and a small drift of the correct diameter is then forced through. The alteration of form which occurs in drawing should be accomplished entirely by the "flow" of the metal, and it is of great importance that

any cutting or scraping action should be avoided. The hole in the die must therefore be made without sharp corners or edges, and should be highly polished to reduce friction and wear to a minimum. Two forms of hole, Fig. 453 (a) and (b), are in such common use that they may almost be regarded as standard. At the same time, it must be allowed that the three sections (c), (d), and (e), shown in Fig. 453, although frequently adopted, do not comply with the conditions just laid down, and from this point of view section (f) would be the correct form to employ. The diameter of the wire drawn through the die is checked from time to time by means of a wire gauge or micrometer, and has to be kept within certain specified limits. The life of a die

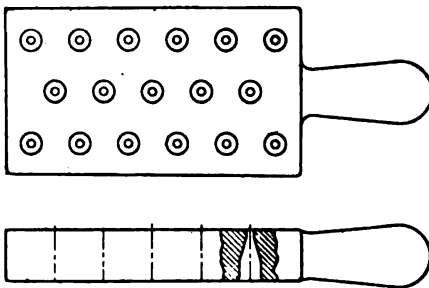

FIG. 452.—"Wortle Plate" or Die Plate for Drawing Wire.

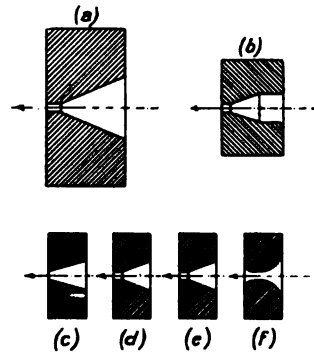

FIG. 453.—Forms of Dies for Drawing Wire.

varies with the size and speed, and the kind of material, but it may be said, for example, that after drawing about $1\frac{1}{2}$ miles of steel wire of 16 S. W. G., the hole will require "battering," *i.e.*, the hole is hammered up slightly, and the drift again forced through. As the hole wears, this process is repeated until the die becomes useless. The wear which is constantly taking place, although slight, renders it extremely difficult to draw long lengths of wire of exactly the same diameter throughout in steel dies, and for finishing, dies made from hard precious stones such as diamonds or rubies, are frequently used. The life of a "stone hole" die very much exceeds that of steel, and may reach as much as three months with constant use.

Dies with Mechanical Adjustment.—The method of wire-draw-

ing still generally practised, has been carried on with little change for centuries, and demands a high degree of skill on the part of the workmen. All the usual types of die require skilled men to set them, and it was until recently the established custom for each wire-drawer to set his own dies. It is now becoming recognised that the operation of wire-drawing can very well be performed by unskilled labour, and the practice is gaining ground of employing skilled die-setters and unskilled wire-drawers. A still further advance has been made by Messrs. W. T. Glover and Co., Ltd., of Trafford Park, Manchester, the well known manufacturers of electric cables, who have introduced a mechanical

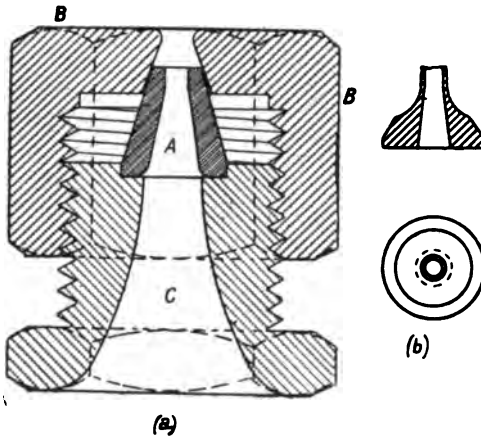

FIG. 454.—Mechanically-adjusted Dies for Wire-drawing.

adjustment for steel dies, which bids fair to dispense with the services of the skilled die-setter. The die consists of a small steel cone, A, having the usual tapered hole bored through its centre as at (a), Fig. 454. The apex of this cone fits into a seat formed in the steel die-holder, B, and the base of the cone lies in a recess in the screwed adjusting block, C. When the block has been screwed up, the die is reamed to the required size. After slight wear has taken place, the hole is closed down to size by again screwing up the block, thus forcing the apex of the conical die into the cone seat provided for it. The die can be closed down and reamed repeatedly, until it assumes the form shown at (b), at which stage it may be replaced at trifling cost. There can be little doubt that this very ingenious improvement is destined to effect a revolution in the old-fashioned practice of wire-drawing still in vogue in many quarters.

Wire-drawing Machinery.—The apparatus employed in carrying out the operation of drawing is termed a *draw-bench*, of which

there are two distinct types, viz., one used for rods, tubes, etc., which must remain straight, and the other for wire, which may be coiled upon a drum as fast as it is produced. A draw-bench of the first kind is shown in Fig. 455. The end of the bar to be drawn is first pointed, and is pushed through the hole in the die until it can be seized by the tongs, which holds automatically, and is carried on

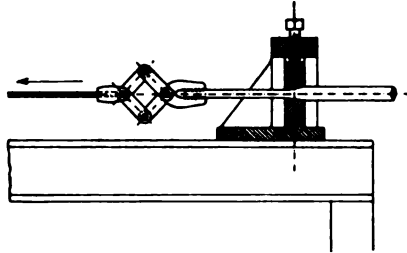

FIG. 455.—Draw-bench for Rods, Tubes, etc.

a slide moved along the bench by suitable mechanism. For driving by power, Fig. 456, an endless flat-link chain runs round pulleys, one at each end

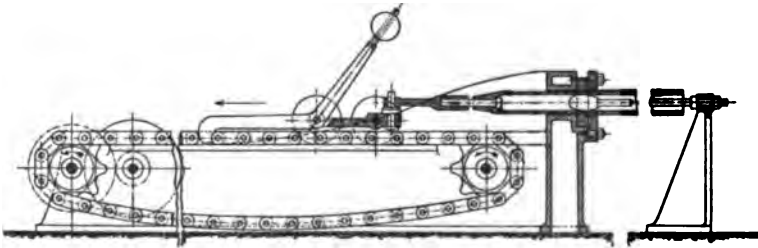

FIG. 456.—Chain-driven Draw-bench for Cold Drawing.

of the bench. A pivoted hook connected with the tube grip-jaw or "dog" may be dropped into the chain in any position,



FIG. 457.—Double Draw-bench for Tubes, etc.

and is automatically thrown out by a tooth of the chain wheel when the end of the travel has been reached, the weighted lever

assisting in the disengagement. The photograph, Fig. 457, shows a draw-bench of this pattern by Messrs. Samuel Platt, Ltd., Wednesbury. Bright-drawn steel bar, of round or hexagonal section, and accurate to size within 0.001 inch, is now produced in large quantities in this way for use in turret lathes and automatic screw machines.

As an example of the second type, the Crossley standard wire-drawing blocks, made by Messrs. George Crossley, Ltd., of Cleckheaton, and shown in Fig. 458, may be taken. The

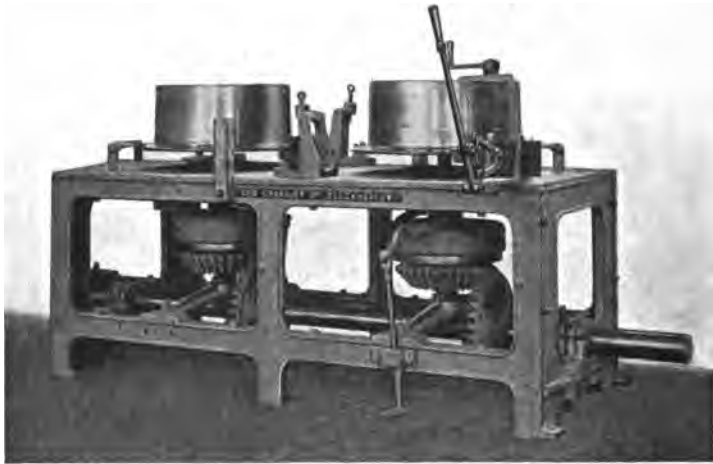
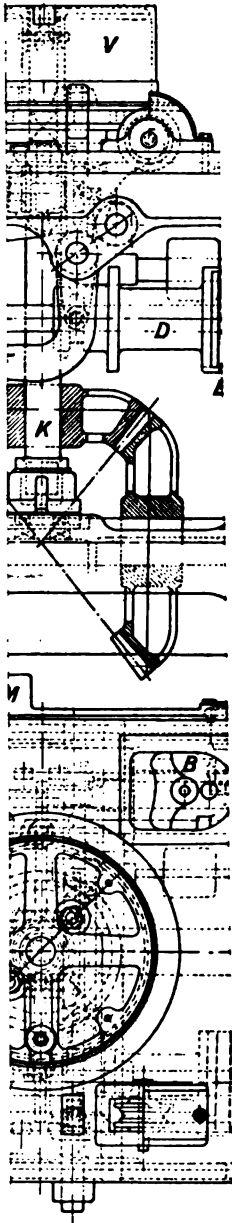

FIG. 459.—Machine for Drawing Wire, with Clutch for driving Blocks.

machine is arranged to work on both sides, and will draw from 5 S.W.G. "ripping" blocks down to 19 S.W.G. A coil of the wire for drawing down is placed upon a drum or "swift," which runs loose on its spindle, as in Fig. 462. The end of the wire is pointed, and is led through the draw-plate carried in the stand, B, which has a slight adjustment round a pivot on the bench, so that the hole in the die may be set exactly in the line of drawing. The end of the wire is seized by the tongs or pincers which is attached to a chain, and the latter, when required, may be coiled upon the drum, D, by throwing into gear the clutch, E, by means of the foot lever, F. The shaft, G, which carries the pulling-in drum, D, is driven from the main shaft, H, by toothed



Rossley Machine for Drilling



gearing. The travel of the tongs thus provided is capable of "pulling in" through the die a sufficient length of wire to "start up the block," *i.e.*, to reach the vice of the drawing block, V, in which it is secured. When sufficient wire has been pulled in, the eye lever on the fulcrum shaft knocks out the pulling-in gear, which is then kept dormant by the counterbalance weight shown. The block, V, runs loose on its spindle, K, which is driven by bevel gearing from the main shaft of the machine. Immediately below the block is the driving plate or "key-block," L, which is

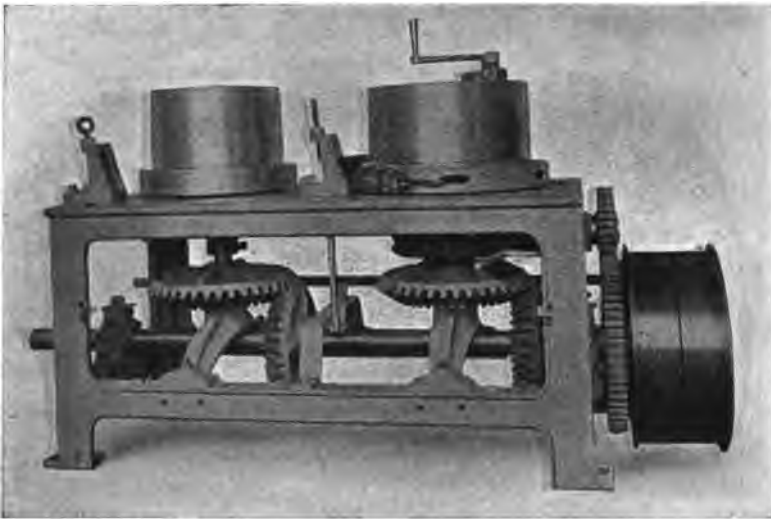

FIG. 460.—Machine for Drawing Two Holes, showing Method of operating Tongs.

fixed on a square on the shaft, K, and is provided with recesses to receive the squared ends of pins fixed in the drawing block. To put the latter in or out of gear, it may be lowered or raised by rods connected to the foot-lever, M. Fig. 459 represents a bench of two medium drawing blocks, also of Messrs. Crossley's manufacture, for drawing wire from 14 to 19 S.W.G. These blocks, being of lighter construction, do not require a foundation. The pull-in motion is by hand instead of power, and the blocks are driven by friction clutches, operated by foot pedal. Fig. 460 shows another of Messrs. Crossley's machines for drawing two holes, or two reductions at one operation. The construction is

similar to the last example, except that the machine is driven by fast and loose pulleys instead of clutches. The drawing-in motion is power driven from the loose pulley by worm-wheel motion, for which purpose the tongs may be hooked into one of the slots in the key-block, as shown separately in Fig. 461. Four or more similar machines combined on one "stand," are sometimes driven from the same shaft, the drawing apparatus being

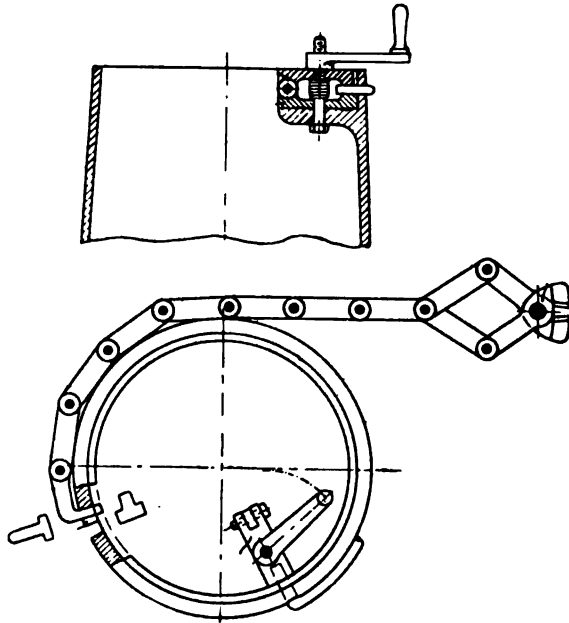

FIG. 461.—Tongs for Wire-drawing Machine.

for convenience arranged alternately right and left of the main frame, Fig. 462.

What are known as continuous or multiple drawing machines have recently been largely developed, in which the wire to be drawn is taken from the swift through the first die, coiled round the first block, then through the second die to the second block, and so on to the finishing block. This results in a considerable increase in production. Messrs. W. T. Glover & Co., Ltd., of Manchester, have devoted considerable attention to this matter, and have produced a series of machines built on sound mechanical

principles, and yet exceedingly simple in construction. It has been found that for drawing copper wire, three sizes of machine will suffice, viz.: (1) for drawing $\frac{1}{2}$ inch diameter copper rods to No. 16 S.W.G., or any intermediate size; (2) for gauges between No. 12 and No. 20 S.W.G.; and (3) for sizes less than No. 20 S.W.G. To give an idea of the rapid rate of working, it might be mentioned that the output of the large machine per day of 10 hours is equal to 2 tons of No. 14 S.W.G. for the

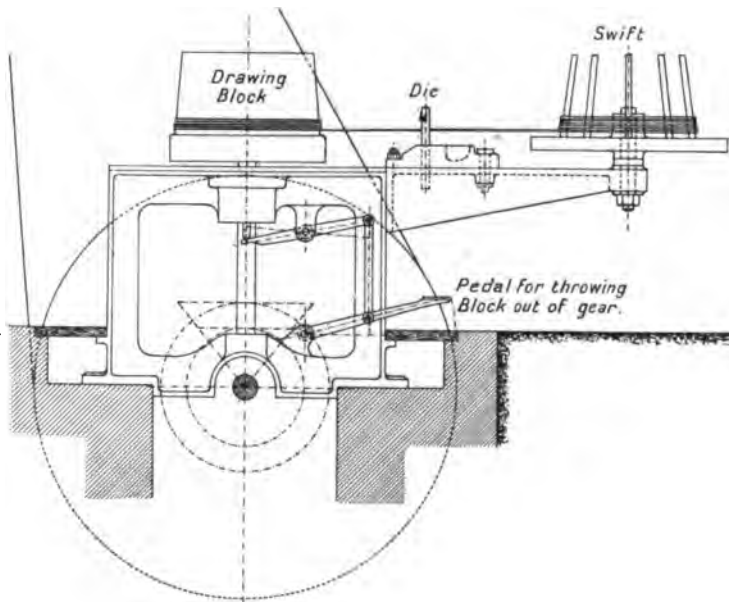

FIG. 462.—“Stand” Arrangement of Wire-drawing Machine.

single machine and 4 tons for the duplex. Each size of machine is provided with nine dies, a number found necessary to effect the desired reduction in the case of copper. The principle on which the machine works will be seen by reference to Fig. 463. Messrs. Glover's duplex horizontal drawing machine for the manufacture of steel wire in all sizes from No. 3 to No. 16 S.W.G., is shown in Fig. 464. For steel, five dies suffice, each being of the adjustable type previously illustrated. Four narrow drums or “blocks,” as they are termed, and a finishing block are therefore mounted on each side of a central frame, constituting

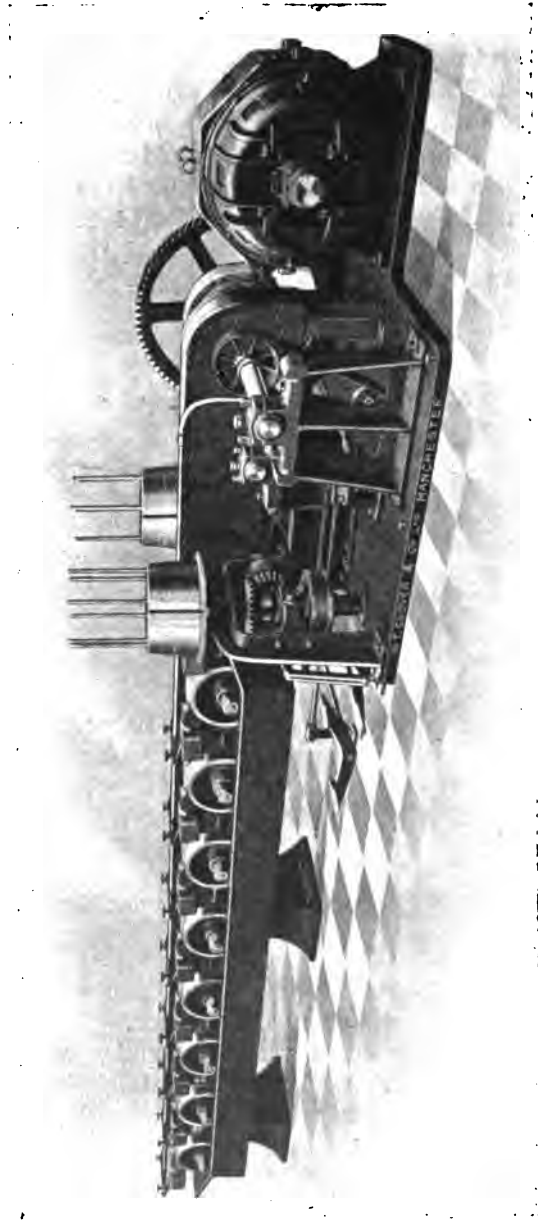

FIG. 468.—Duplex Drawing Machine for Copper Wire.

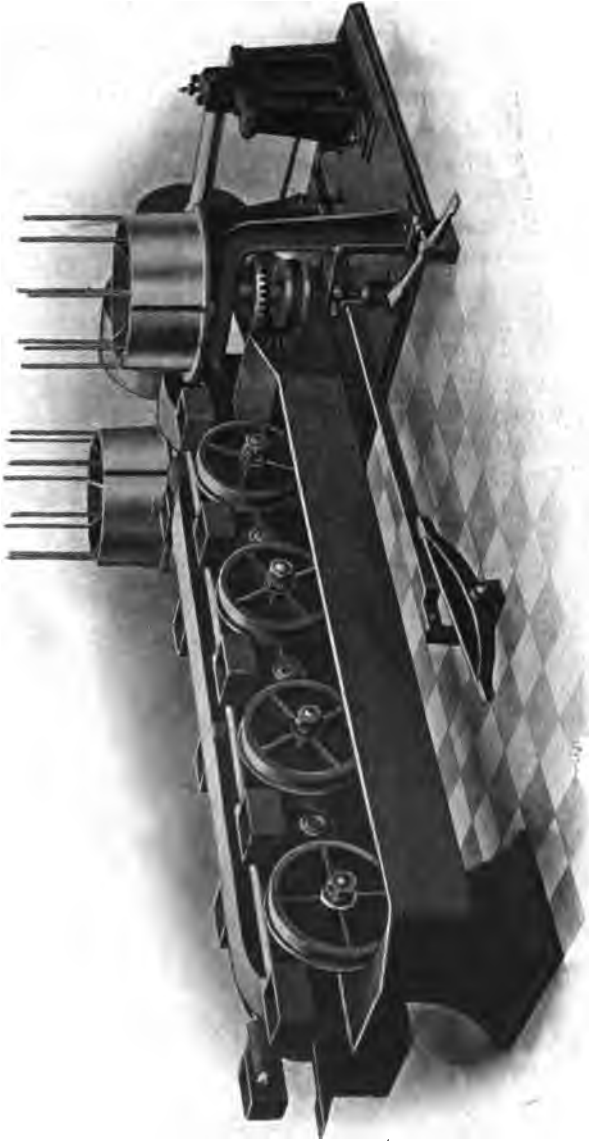

FIG. 464.—Duplex Drawing Machine for Steel Wire.

in effect two distinct five-die machines placed back to back. The blocks are positively driven through a double range of helical gears by a horizontal shaft, which is provided with a powerful friction clutch operated by a foot lever at the side of the machine. It will be noticed that as the diameter of the wire is reduced, the velocity of drawing must be increased. Therefore the blocks do not all revolve at the same speed, but the circumferential velocities must in each case be accurately adjusted to the speed of drawing by properly proportioning the sizes of the gears by which they are driven. Each side of the machine is connected to the main drive through a separate friction clutch controlled by foot lever placed near the finishing block. This arrangement renders it possible for the attendant to insert or "string up" a new length of wire on one side of the machine while drawing is proceeding on the other side. The die boxes contain solid lubricant, through which the wire passes before entering the die, but troughs are provided under the four drums on each side for the alternative use of liquid lubricant. For the production of copper wire, the design of the machine remains the same, its length being extended to accommodate nine instead of five dies on each side.

CHAPTER XXXIX.

THE MANUFACTURE OF TUBES.

THE simplest method of tube-making is that employed for *wrought iron gas pipe*, which consists in butt-welding the edges of a long strip of thin sheet previously bent to circular form, Fig. 465 (a). The strip is first heated, the end bent over by hand as shown in Fig. 465 (b), and then pulled through a funnel-shaped former on a draw bench, Fig. 465 (c). After bending in this way, the roll is raised to welding heat, and the edges welded by passing through rolls, or by rapidly drawing through a draw plate. For small tubes the rolling and welding may proceed simultaneously during the drawing process, as shown.

Lapwelded Steam Pipe, Fig. 466 (a), is produced from strips or "skelps," which are first scarfed at the edges by rolling, or in a special planing machine. The strip is heated and bent to shape round a mandrel by hand, after which it is raised to a welding heat, and passed through rollers over a fixed mandrel supported on the end of a long rod, Fig. 466 (b). This arrangement enables sufficient pressure to be applied to effect a satisfactory weld, whilst preserving the circular form of the tube. Both the above methods are practically confined to the use of wrought iron as the material of which the tube is composed.

"**Solid-drawn**" Tubes of copper, brass, and steel may be produced without joint by drawing out in the same way as wire.

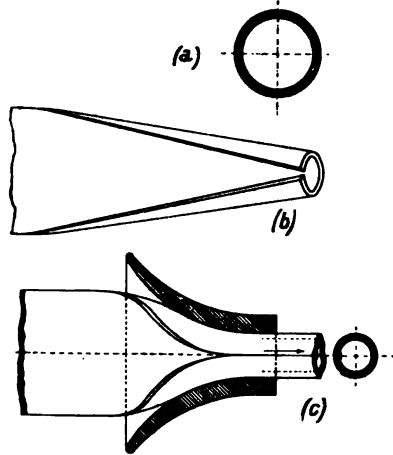

FIG. 465.—Manufacture of Wrought Iron Gas Pipe.

Originally, tubes were drawn upon a *long mandrel*, having a length somewhat greater than that of the finished tube, but this system

is now only employed for the very thin and accurately fitted brass tubes used for telescopes and optical instruments. A short and comparatively thick tube is made by bending a piece of sheet brass, the edges of which have been previously notched and fitted together in a series of dovetails as in Fig. 467 (a). These are brazed together, and the joint carefully dressed to the truly circular form. This is known as a "cramped joint," and is much used by coppersmiths. The piece to be drawn is then fixed upon a polished steel mandrel, the end being turned over the shoulder as in Fig. 467 (b). The mandrel with the tube upon it is then drawn repeatedly through draw plates of smaller and smaller size, until the required external diameter is obtained, the internal diameter of course remaining the same as that of the mandrel. The

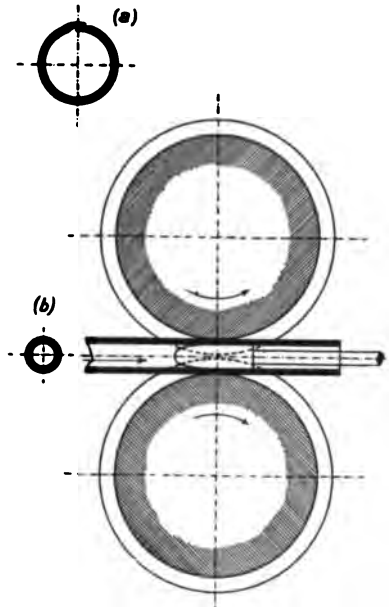

FIG. 466.—Manufacture of Wrought Iron Steam Pipe.

repeatedly through draw plates of smaller and smaller size, until the required external diameter is obtained, the internal diameter of course remaining the same as that of the mandrel. The

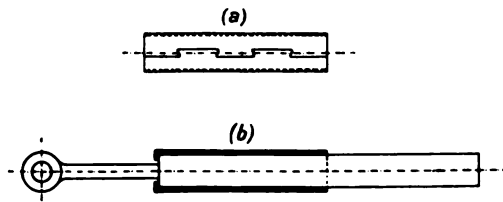

FIG. 467.—Manufacture of Brass and Copper Tubes.

original piece from which the tube is drawn may be made from a casting, turned on the outside, and bored to fit the mandrel, and a solid-drawn tube would then result.

Solid-Drawn Tubes of copper, brass, or steel are now produced

by what is known as the *short mandrel* system, in which the original thick piece is "cold drawn" through a die as before, but *over* a mandrel, which is stationary, being supported on the end of a rod of somewhat greater length than the finished tube, Fig. 456.

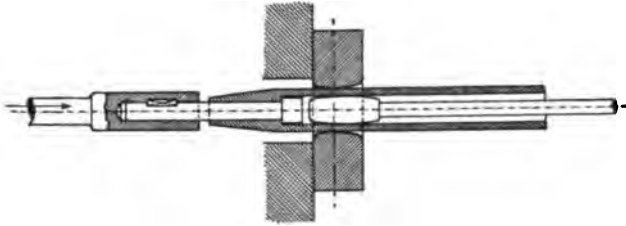

FIG. 468.—Manufacture of Solid-drawn Tube.

The cylindrical piece from which the tube is drawn, is turned and bored out of solid bar of the desired quality, and instead of using tongs as is done for wire, it is coupled to the slide of the draw-bench by means of a bolt and cotter, as in Fig. 468. The mandrel or "plug" is of hardened steel of a bulb-headed form, and is fixed so that its greatest diameter comes exactly in line with the smallest diameter of the conical hole in the die. It is necessary to anneal the tube frequently during the drawing process to restore the ductility of the metal, for the same reason and in the same way as in wire-drawing.

Hydraulic Tubes.—Extra thick solid-drawn steel tubes may be obtained suitable for hydraulic pressures up to 2 or $2\frac{1}{2}$ tons per square inch. The thickness varies from $\frac{1}{4}$ inch for tubes $\frac{7}{8}$ inch in diameter, up to $\frac{3}{8}$ inch for a diameter of 2 inches. Such tubes are also useful for the purpose of producing the hollow screws employed in lathes and other machine tools.

Weldless Steel Tubes are produced by drawing down from a short and thick hollow cylinder punched or machined out of a solid block. The production of the perforated billet is thus the first step in the manufacture of weldless steel tubes. A very interesting process first introduced by Ehrhardt, in Germany, is shown in principle in Fig. 469. A square block



FIG. 469.—Manufacture of Weldless Steel Tube.

of mild steel, previously raised to a bright red heat, is placed in the round hole of a thick cylindrical die, and a punch is driven

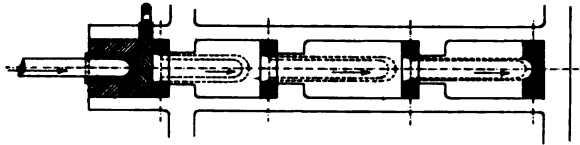

FIG. 470.—Manufacture of Weldless Steel Tube.

into the block by hydraulic pressure, thus expanding the metal in the die, and leaving a short thick tube, closed at its lower end. As the sectional area of the tube must be the same as that of the square block from which it was formed, it follows that

$$s = \frac{D}{\sqrt{2}}, \text{ and } \frac{\pi}{4} d^2 = \left(\frac{\pi}{4} D^2 \right) - s^2,$$

where d and D = diameters of punch and die respectively, and s = side of square block. From this the diameter of the punch must be

$$d = 0.6 D.$$

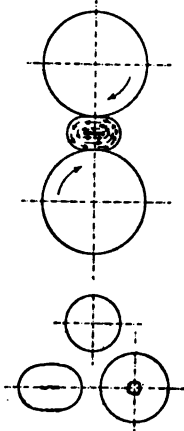

FIG. 472.—Three Stages in Rolling Thick Tube.

The bottom of the die rests against a strong plate, which may be withdrawn laterally after the block has been punched to the proper depth. The resulting cylindrical piece is then forced through a number of dies in succession, the external diameter being reduced, and the length increased at each draw, Fig. 470. The initial stage of the drawing is thus carried out in the heated state, and is continued so long as the somewhat rapid cooling of the piece will permit. Further reduction may then be accomplished when cold by means of the draw-bench, working in the ordinary manner, as already described. For this purpose, the thick end of the tube may be drawn down and flattened or "tagged,"

to enable it to be gripped by the tongs, as shown in Fig. 479.

Suppose that a cylinder of mild steel at a bright red heat is placed between rolls, the axes of which are parallel, and which are made to revolve in the *same* direction. The cylinder will be

somewhat compressed, and by friction with the rolls, the material on the top and bottom sides of the flattened piece will be extended in opposite directions by the action of rolling, as indicated by arrows in Fig. 471. The result is a tendency to develop a crack or fissure at the centre, which, on the removal of the piece from the rolls, could be caused by the application of pressure at the ends to assume the form of a cylindrical cavity. Fig. 472 shows the initial form of the cylinder, the flattened shape produced by rolling, with the fissure at the centre, and

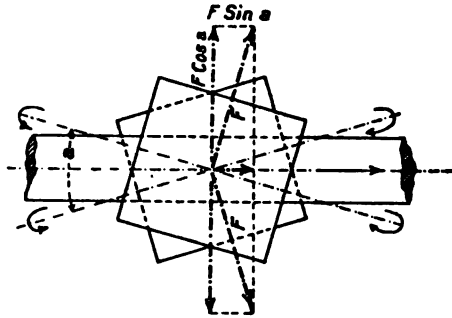

FIG. 473.—Production of Tube by Rolling.

the restoration to the original circular form, leaving an approximately cylindrical cavity, the section resembling a very thick tube. This action must, however, be regarded as confined to a very short length, and the process is not continuous. Suppose now, Fig. 473, that the axes of the rolls, whilst still contained in

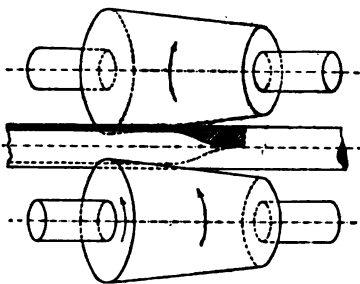

FIG. 474.—Principle of Mannesmann Process of Tube Making.

horizontal planes, are inclined at an angle α with each other. On rotation taking place in the direction of the arrows, the force, F , due to friction between the rolls and the piece may be resolved into its components, $F \sin \alpha$, and $F \cos \alpha$, respectively parallel and at right angles to the axis of the piece. Then whilst rolling is being effected by the action of the

latter component, a continuous forward movement is given to the work in the direction of its own axis by the component $F \sin \alpha$.

Seamless Rolled Tubes are made by this very ingenious and original process due to Mannesmann, of Remscheid. The principle of the Mannesmann process is seen in Fig. 474 A solid

cylindrical block of mild steel is raised to a welding heat, and is passed through conical rollers, the axes of which are set at a slight angle. The rolls rotate at a high velocity in the direction of the arrows, causing the block to revolve, and at the same time imparting to it a forward motion in a direction from right to left in the figure, or towards the larger ends of the rolls. To prevent

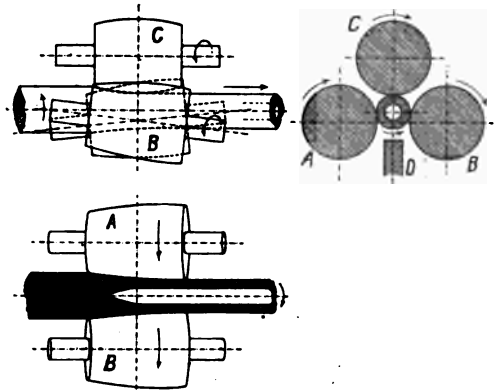

FIG. 475.—Mannesmann Process of Tube Making.

the work being forced out laterally, at least three rolls are necessary, Fig. 475, two of which, A and B, are the working rolls, the third, C, being simply a pressure or guide roll. In the actual machine, the so-called safety rail, D, is also added to support the tube when its diameter has been reduced to the same dimension as the least distance between the rolls. Suppose the diameter

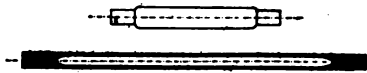

FIG. 476.—Mannesmann Tube with closed ends.

of the block to be equal to the distance between the rolls at the narrowest part, the block would simply pass through the rolls unaltered. If the diameter exceeds the distance named, the block is seized by the rolls, and caused to turn with a screw-like motion. As the diameter of the rolls constantly increases from the point where the distance between them is least, the tendency is to impart an increasing velocity to the outer surface of the block, which in consequence is drawn out at a more rapid rate than the interior, and the plastic condition of the metal in the hot state permits of this being carried out to such an extent that a tube

results. It is in fact possible in this way to produce a tube with closed ends, Fig. 476, provided that the ends of the solid block before rolling are reduced to a diameter somewhat less than the least distance apart of the rolls, the diameter of the intervening portion being as much greater as is required to give a tube of the desired size. The space in the interior of the completed tube with closed ends is not, as



FIG. 477.—Use of Conical Mandrel.

might be expected, a vacuum, but, curiously enough, has been found on examination to contain highly rarefied hydrogen. The process as described is defective in certain directions, inasmuch as it is extremely difficult to obtain tubes exactly of the thickness required, and with a smooth interior. It has therefore been found necessary to roll out the tube over a conical mandrel, Fig. 477, which rotates with the tube as it is formed.

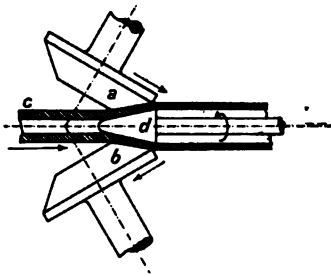

FIG. 478.—Production of Tubes of Large Diameter.

The mandrel, *a*, is fixed upon the end of a rod, which is prevented from deflecting laterally by the guide block, *b*, sliding in the hollow bar, *c*. In this way tubes of from $1\frac{1}{2}$ to 6 inches internal diameter are manufactured, and larger sizes

up to 12 inches may be obtained by employing an arrangement of expanding rolls introduced by Stiefel and shown diagrammatically in Fig. 478. The two conical rolls, *a* and *b*, rotate very rapidly in the direction of the arrows, whilst the thick tube, *c*, to be expanded, and the mandrel, *d*, revolve together at the same speed, the mandrel being supported on the end of a long bar, as before. The tube is finally made smooth and brought to exact dimensions by drawing through a die in which a short mandrel is inserted, exactly as described for solid-drawn tubes, the solid end of the original block being left on for the purpose, Fig. 479. The Mannesmann process of tube-making is a somewhat severe test of the quality of the material employed,

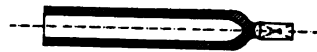

FIG. 479.—Thick Tube ready for Drawing.

The Mannesmann process of tube-making is a somewhat severe test of the quality of the material employed,

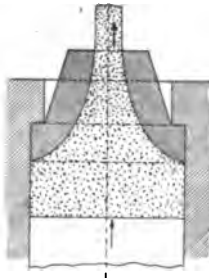

FIG. 480.—"Squirting" Plastic Material.

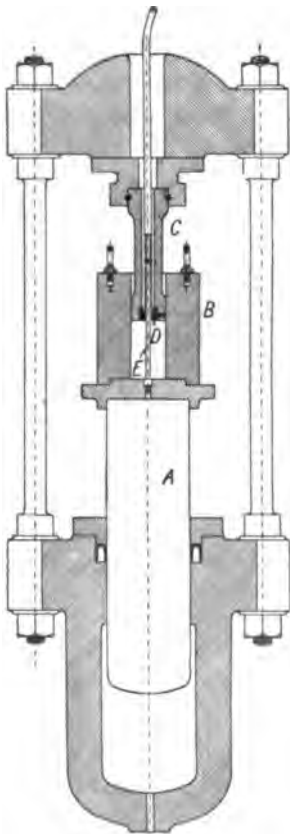

FIG. 481.—Hydraulic Press for "Squirting" Lead Pipe.

which in itself may be taken as a guarantee that such tubes must necessarily be of the very highest class. Any flaw in the original block is certain to result in the production of a fracture which cannot escape notice, and will, in fact, cause the working of the rolls to be temporarily suspended.

Tubes of Plastic Material.—A process, closely allied to that of wire-drawing, is frequently employed for the production of rods and tubes of plastic or semi-solid material by forcing it through a die under pressure. If a cylinder having a hole at one end, Fig. 480, be filled with soft plastic material, upon which pressure is exerted by means of a tightly-fitting plunger, "solid flow" may be induced, the substance issuing from the opening in the form of rod or wire. This principle, which has been utilised in the manufacture of maccaroni, and in the plastic process of brick-making, receives its most interesting application in the conversion of metals, such as lead and tin, into the form of pipes and rods of various sections.

"Squirting" Lead Rod and Pipe.—A special form of hydraulic press, shown in Fig. 481, is employed for this purpose. The water ram, A, of the press carries a strong steel cylinder or container, B, into which molten lead may be poured from an adjacent lead pot. The container is provided with an external heating arrangement, so that the lead may be kept warm, and in a state just upon the point of solidification. The top of the container

is fitted with a plunger or lead ram, C, which can be easily removed, and at the lower end of the plunger is inserted a steel die, D, having a rounded opening, the smallest diameter of which corresponds to the outside diameter of the pipe or rod required. If pipe is to be produced, a mandrel, E, having the same diameter as the intended bore, is fixed in the end of the water ram, or may be carried by the container, in such a manner as to project through the die, leaving an annular space equal to the section of

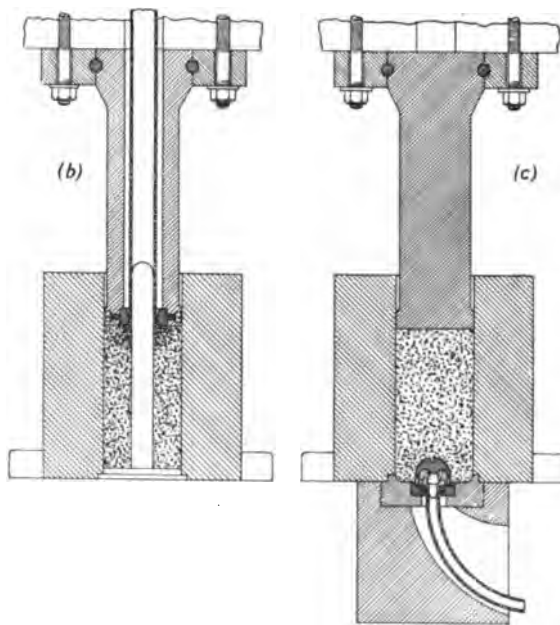

FIG. 482. —Arrangement of Dies and Container for "Squirting" Lead Pipe.

the pipe. On admitting water pressure to the ram, the lead is "squirted" or extruded through the opening in the die, and the resulting rod or pipe, as the case may be, is coiled upon a drum as it leaves the machine. The core may be carried on a narrow bridge piece spanning across from side to side of the hole in the die. This, of course, has the effect of separating the outflowing stream of lead into two parts of approximately semicircular section, and although these re-combine under the pressure put upon them in passing out of the die, it has sometimes been found, probably on account of the imperfect form of the nozzle, that the

junction is not always perfect, and that the pipes so made may be liable to split. The first system shown in Fig. 481, and at (b), Fig. 482, is that known as the "long core" arrangement. Here the core which forms the hole in the pipe has to be fixed in position

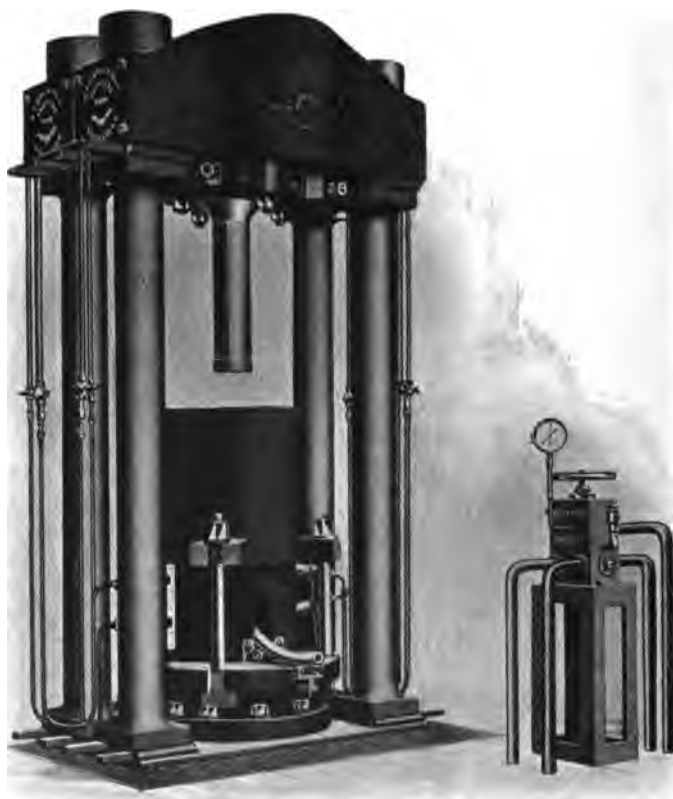

FIG. 483.—Press for making $1\frac{1}{2}$ -in. Lead Pipe.

right through the centre of the mass of molten lead in the container. The core is thus subjected to constant heating and cooling, which not only roughens its surface, but also warps and bends it out of shape, rendering it difficult to form a true pipe. Messrs. W. T. Glover & Co., Ltd., of Trafford Park, Manchester, have, by careful design and proper proportion of the

parts, succeeded in producing a form of die box which is free from these defects. The core is held in the bottom of the container by means of a bridge or feet, and fits into the recess carrying the die. On the application of pressure, the lead is forced

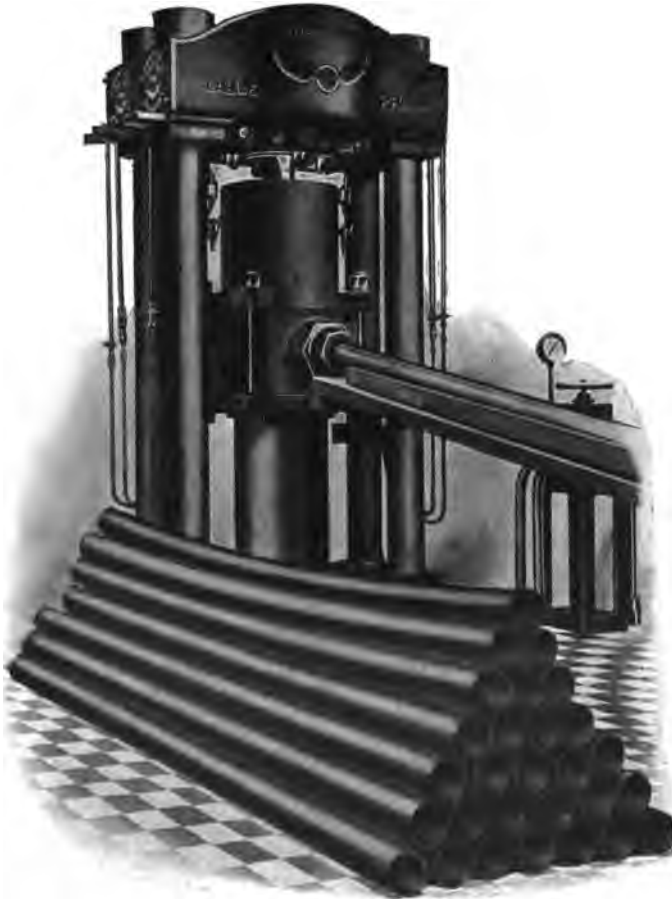
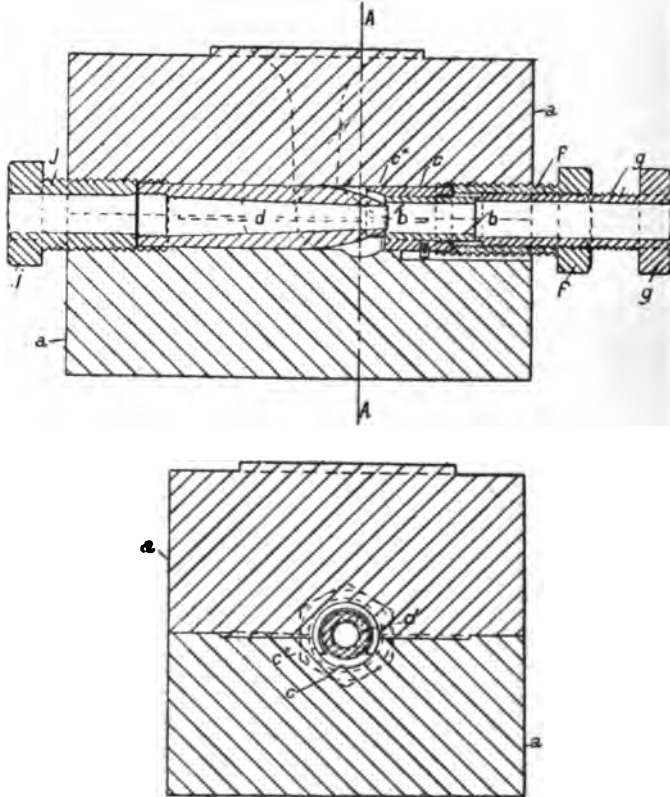

FIG. 484.—Press for making 4-inch Soil Pipe.

over the bridge of the core, but reunites immediately in a conical space provided for the purpose, the junction being effected by the pressure to which the metal is subjected in passing out through the aperture formed by the core and the die. This is shown at (c), Fig. 482. It is quite a simple matter for air spaces

to be formed in the core, which effectually prevents the lead reuniting, but this is obviated entirely in Messrs. Glover's arrangement, and as the surface of the metal does not come in contact with the atmosphere, and cannot therefore become oxidised, a perfect combination is rendered possible. Fig. 483 shows the



Section A.A.

FIG. 485.—Dies for Lead-covering Electric Cables.

Glover press as used for making $1\frac{1}{2}$ -inch lead pipe. The hydraulic cylinder, being beneath the floor, is not seen in the illustration. The top of the ram, with the table fixed to it, just appears above the floor level. To the table the container is bolted, a hollow block being placed between them. The die and core for forming the pipe are placed in a vertical position in the upper

part of the hollow block, and immediately beneath the container. When pressure is applied, the lead pipe is extruded through the slot in the hollow block in front of the press. This is a much



FIG. 486.—Press for Lead-covering Electric Cable 4-inch diameter.

more convenient arrangement than to cause the pipe to pass upwards through the top of the press, from which it has to be brought down to the floor. Fig. 484 shows a Glover press for making 4-inch soil pipe. In this case, the hollow block, as described in the previous figure, is replaced by a core box with

the die and core fixed in a horizontal position, as it is advisable to avoid bending the larger sizes of pipe any more than is necessary. The illustration shows that large sizes of pipe may readily be cut to length required as they are extruded, and stacked upon the floor.

Lead-covered Cables.—When covering electric cables with lead, much greater care is required than in the manufacture of pipe, as not only must the covering be perfectly concentric, but it is essential to avoid damage to the cable itself, either by heat from the molten lead, or by moisture from the hydraulic cylinder. As the cable has to pass through the core, the latter must be made hollow, a patented arrangement due to Messrs. Glover being shown in Fig. 485. The die box, *a*, is fixed in the press between the table and the container, as seen in Fig. 486, the supply of lead from the container entering by the conical-shaped opening shown in dotted lines. The core, *d*, to suit the size of cable to be covered, is secured in position by the hollow screw, *j*. The shell *c*, and die, *b*, are inserted from the opposite end of the box, and their positions relative to the core, *d*, may be adjusted by the screws, *f* and *g*, to give the required thickness of covering. The projecting end, *c*², of the shell, *c*, enables the supply of lead on the upper side of the cable to be equalised, and a covering of even thickness is obtained without the use of a bridge. A complete press for covering a 4-inch diameter cable is seen in Fig. 486.

Extruded Rods of Metal, etc.—Not only lead, but other metals such as copper, phosphor bronze, muntz metal, etc., may be extruded, and *carbons for arc lamps* are produced by a similar process. Graphite, coke, gas carbon, and other substances are ground to a fine powder in a ball mill, and mixed with hot tar to form a stiff, pasty mass, which is then forced through a die of the proper form by means of a hydraulic press. The resulting rods are then raised to a high temperature in crucibles.

CHAPTER XL.

MANIPULATION OF METALS BY FLANGING, DISHING, DRAWING, ETC.

THE use of the press is not confined to forging and stamping, but has been extended in many directions, especially in the working of plates and sheet metal. These processes may be said to be derived from the operation of *Flanging and Dishing* plates for boilers and similar purposes. Formerly plates were flanged by hand, being bent when in a red-hot condition over a cast iron "form" of the proper shape by blows from wooden hammers, Fig. 487. The operation was performed by a number of men working simultaneously, from two to six being employed

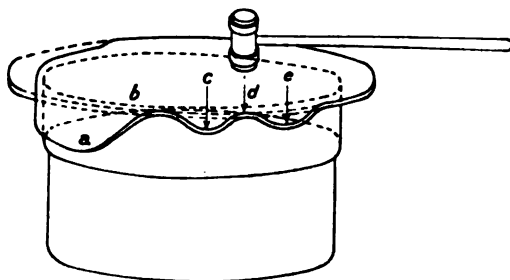

FIG. 487.—Flanging a Plate by Hand.

according to the size of the plate. Along the portion *a*, *b*, where flanging is just commencing, it will be seen that the metal is subjected to a "drawing out" action. But after delivering blows at (say) *c* and *e*, it is important that the formation of a crease should be prevented by blows upon the intervening portion at *d*. This results in "jumping up" the material at *d*, the force of the blow being resolved into components along the directions towards *c* and *e*. The drawing down during the first part of the operation, followed by jumping up the same material all round the flange to prevent creasing, necessarily renders such

work liable to imperfections, whilst at the same time it is slow, and therefore very costly. With the *Hydraulic Flanging Press*,

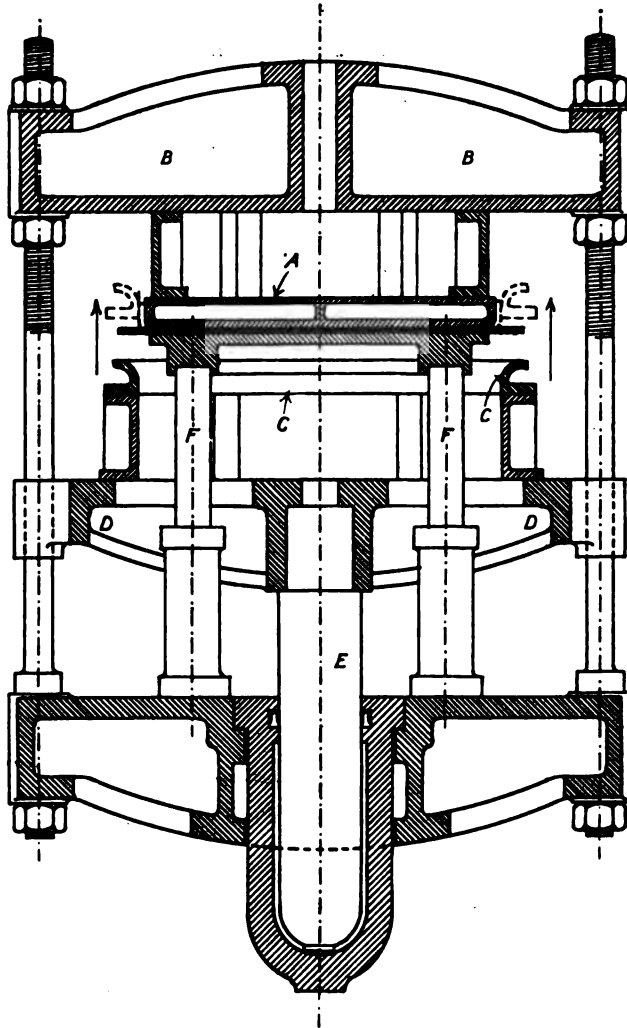

FIG. 488.—Hydraulic Flanging Press.

Fig. 488, on the other hand, the operation is rapidly performed at one heat, and any desired shape of plate may be produced. The upper die, or inside form, A, corresponding to the required

shape of the plate, is carried upon stools bolted to the underside of the cross girder, B, the position of which may be adjusted to suit the work in hand by means of nuts on the screwed ends of the main pillars. The lower or flanging die, C, the edge of which is curved outwards to a large radius, is supported on stools fixed upon the table, D, attached to the main ram, E. In addition four "vice" rams, F, are provided, worked from the same supply as

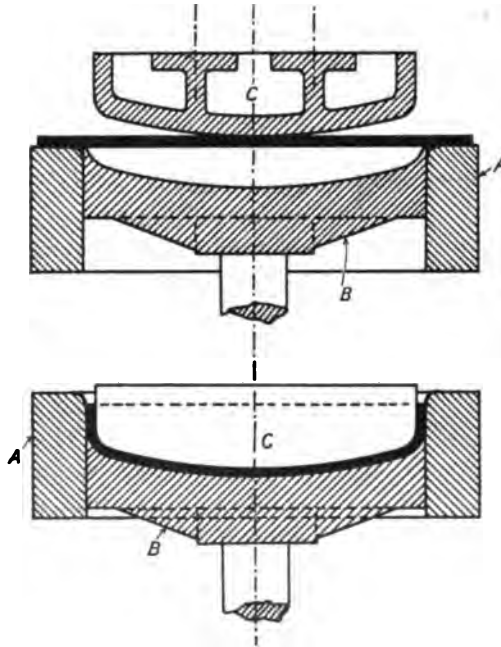

FIG. 489.—Flanging a Dished End by Hydraulic Pressure.

the main cylinder. The heated plate is first placed in position on the lower die, C, when it is raised by the vice rams, and clamped firmly against the upper die, A. The main ram is then advanced, bringing the lower die into the position shown in dotted lines, to complete the flanging. The same principle is made use of in a press on Tweddell's system for flanging a dished end, Fig. 489. The plate to be flanged is made red-hot, and is placed upon a ring, A, secured to the table of the machine. The vice ram is then raised, carrying with it the lower die, B, and

when this has been brought into contact with the plate, the main ram, C, descends, dishing the plate, and overcoming the pressure on the vice ram, completes the flanging by forcing the plate inside the ring, A.

Press Stamping and Drawing.—The flanging, etc., of the comparatively thick plates used for steam boilers and similar

purposes is carried out in a heated condition, but the working of thin sheet metal must necessarily be done cold. Two distinct types of press are employed: (1) Single-acting, having only one slide, which is driven by crank and connecting rod motion from the main shaft of the machine; and (2) double-acting, *i.e.*, having an inner and outer slide, the former driven by crank mechanism as before, and the latter either by cams, or preferably by toggle gear, as will be described later. In the single-acting press, the slide carries the punch, and the die is fixed to the frame of the machine. The operation is essentially that of punching thin sheet, on the principle that any desired form may be given to the punch and die. Armature discs and segments for electric motors and dynamos, magnet pole and pole shoe stampings, parts of switch gear, and other electrical fittings of a similar character, are well-known examples of work of this description. By modification of the dies, the range of work may be made to include perforating, bending, and forming, if the object is of no great depth. Steel pens, buttons, parts of clocks and watches, light jewellery, etc., are produced in this way.

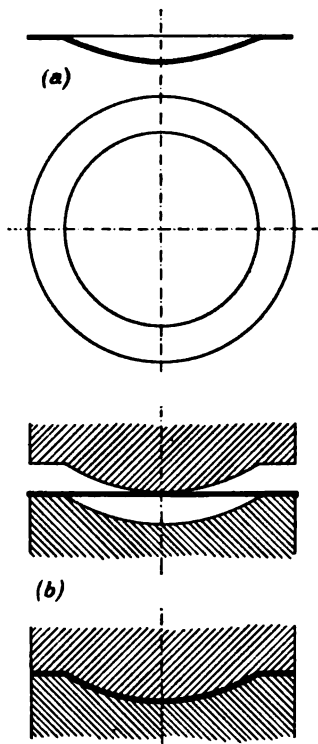

FIG. 490.—Stamping a Metal Dish.

Suppose it is required to produce in thin sheet metal the article represented in Fig. 490 (a), the press tool is employed in its simplest form, which consists of a punch and a die or

matrix. The dishing of the plate or blank placed between the punch and the die Fig. 490, (b), can only be effected by an increase in length in the direction of the diameter, or by a reduction in the thickness of the plate, or what is perhaps most likely to occur, by a combination of these two displacements. A tensile stress is therefore set up in the direction of the diameter, coupled with compression in the direction of the thickness of the plate. The result is a tendency to cause puckering or creasing of the plate, especially near the edge or flange. This is most marked in attempting to produce a vessel of any depth, as in Fig. 491, which also serves to illustrate another difficulty, viz., that of withdrawing the article from the die after it has been formed. The trouble is avoided by the use of the "pressure plate" or blank holder, Fig. 492, which is the essential feature in the process of producing a seamless metal cup from a flat blank. For articles with parallel sides, the dies are of the "push-through" pattern, as shown, which enables the finished piece to be discharged quite through the lower die. The blank is slightly thicker than the depth of the recess in the lower die in which it is placed, and it is therefore held under pressure by the blank holder which descends upon it during the down stroke of the machine. The punch is now brought to bear upon the blank, "drawing" it from between the blank holder and the upper

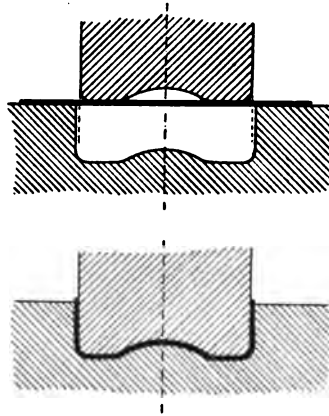

FIG. 491.—Stamping a Deep Vessel.

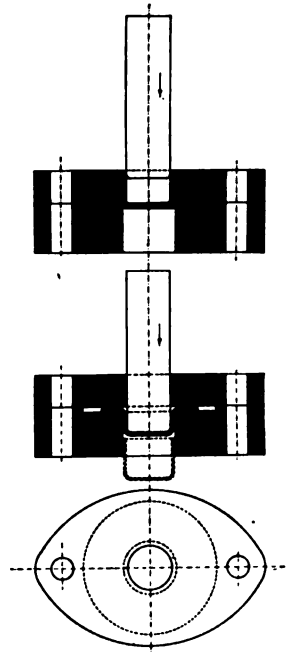

FIG. 492.—Stamping Seamless Metal Cup from Flat Blank.

surface of the die and over the rounded edge of the latter, to give the shape required. Without the blank holder, the disc

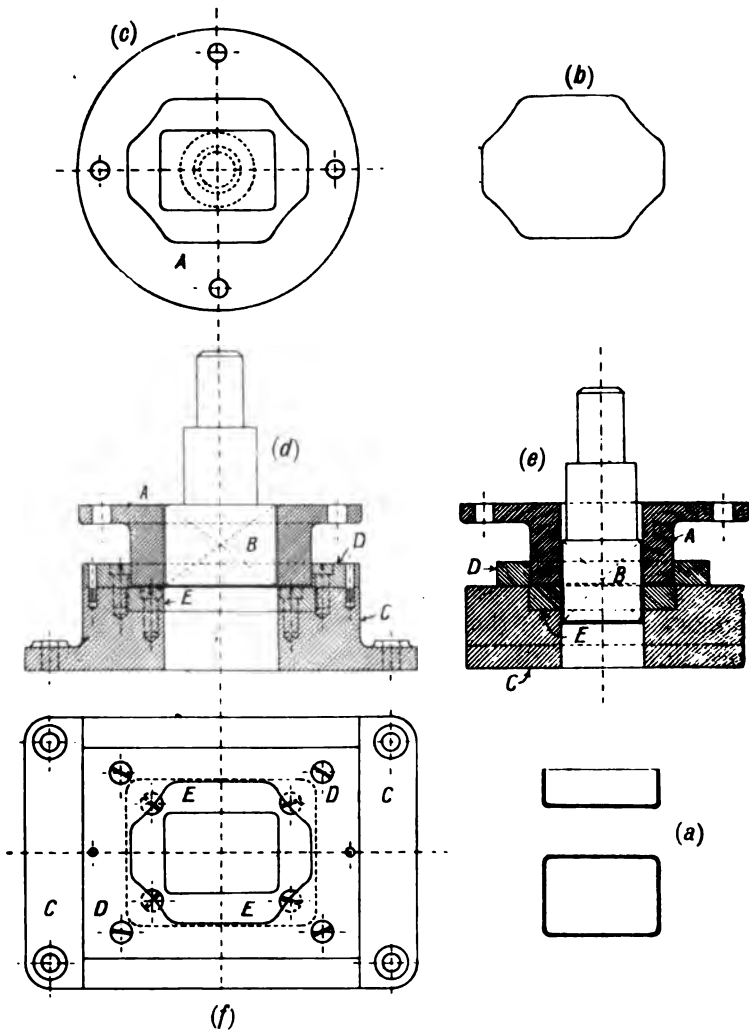

FIG. 493.—Tools for Drawing Rectangular Box of Copper.

would wrinkle or crease all round the edge due to the action of the punch, but the pressure applied by the blank holder prevents the formation of creases, and might be said to smooth

them out as rapidly as they are formed. It should be understood that the sheet metal is held with sufficient pressure between the blank holder and the bottom die to permit the drawing action to take place, which, it will be seen, depends largely upon the ductility of the metal, and its capacity for "flowing" in a cold state. The process is not restricted to objects of circular shape, but is equally applicable to those of rectangular form. In this case, the blank must first be cut to the proper shape, for which purpose the outside of the blank holder is provided with a cutting edge, and made to do duty as a punch. Hence, a blank is cut out, and drawn to shape at each stroke of the press. An interesting example is given in Fig. 493, which shows a set of tools for making a rectangular copper box, (a), $4\frac{3}{4}$ inches long, $3\frac{1}{2}$ inches wide, and $1\frac{1}{2}$ inches deep, the stock used being about $\frac{1}{8}\frac{1}{4}$ inch thick. To produce this box by drawing, requires that the blank shall first be cut to the shape shown at (b). The correct size and shape of blank is, in such a case, best determined by experiment, commencing with as close an approximation as calculation and judgment may decide, and working in the first place with the drawing dies only. Fig. 493 (c) is a plan of the underside of the blank holder or cutting punch, A, which is provided with a circular flange for attachment to the ram of the press. The outside or cutting edge is of the same shape as the blank (b), and the rectangular hole through the centre corresponds to the exterior of the finished box. The drawing punch, B, seen in the views (d), (e), has a cylindrical shank to fit the drawing plunger of the press, the rectangular portion at the bottom being of the same size as the interior of the finished box. The bottom die shown in plan at (f), consists of a holder, C, and two dies, the cutting die, D, of the same shape as the blank, and the drawing die, E, the hole in which is the size of the outside of the finished box. The machine is adjusted until the face of the cutting punch just binds the blank on the face of the drawing die, as at (d). The drawing punch then descends, as at (e), and the completed box is pushed through the die without the aid of any device for extracting. The speed of the press is about 45 revolutions per minute, producing 1,200 boxes per hour. In many cases, especially with articles of considerable depth, the required form is not imparted at one blow, but the drawing takes place a little at a time in a succession of dies of gradually diminishing

diameter. Should the metal show signs of becoming crystalline, it must be annealed, and during the drawing process two or three annealings may be necessary. This process is known as *re-*

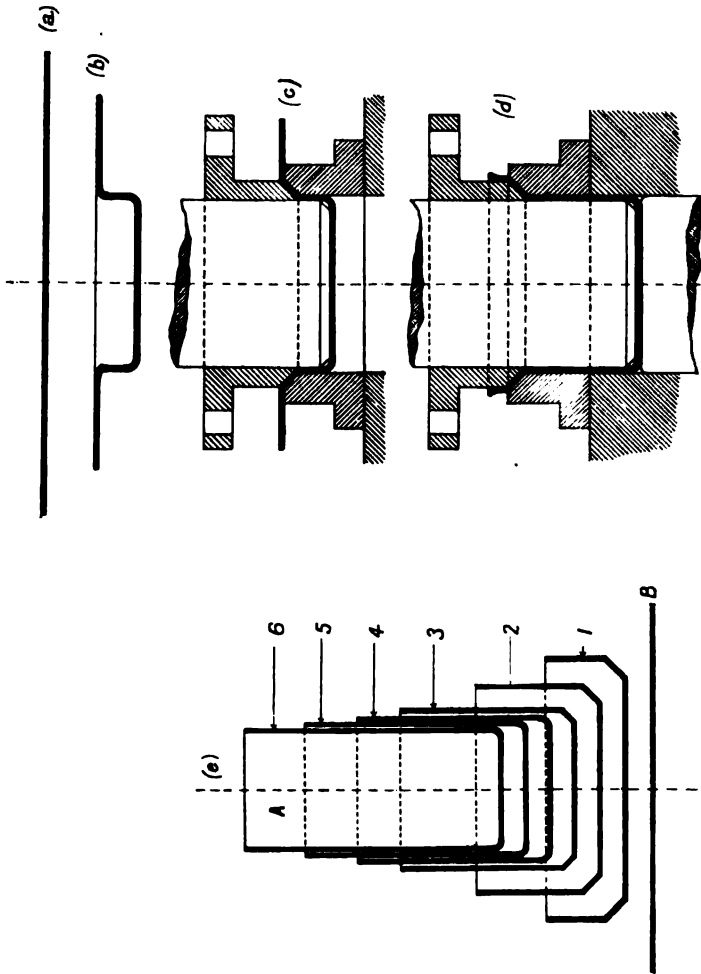

FIG. 494.—"Re-drawing" for Deep Articles.

drawing, and the dies used for the purpose are generally arranged as in Fig. 494, with an inside blank holder, or pressure ring. The blank, (a), is first drawn to the shape, (b), in dies having an outside blank holder, as already shown in Fig. 493. Proceeding to the re-drawing dies, as at (c), Fig. 494, the work is held

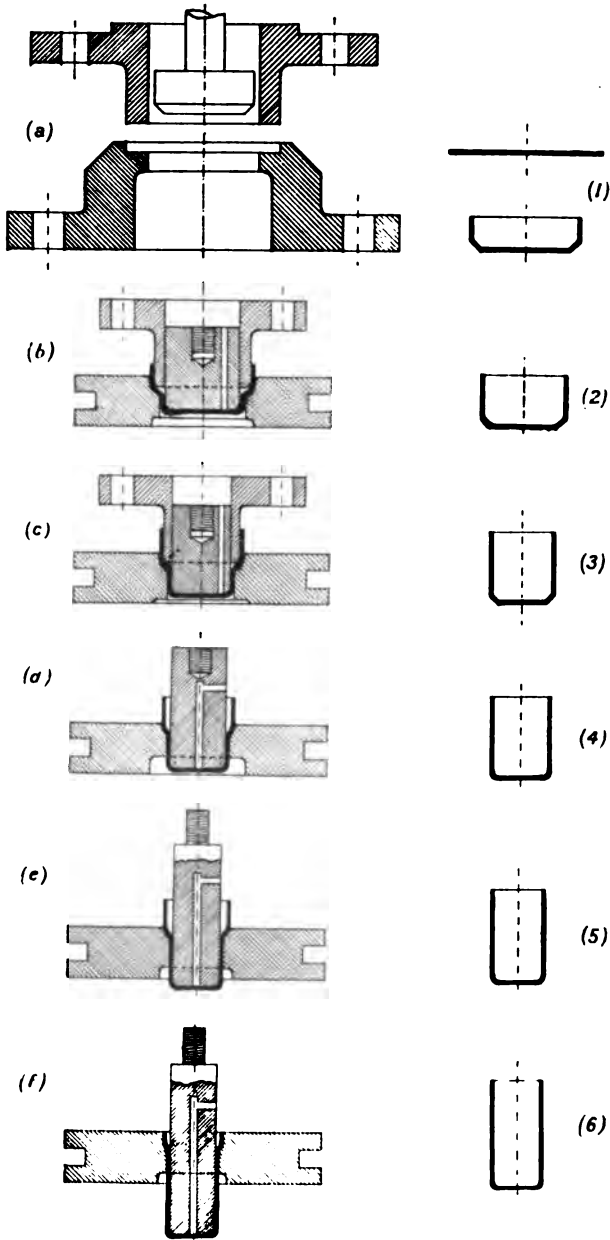

FIG. 495.—Stages in Drawing Steel Canister.

between the bevelled edges of the lower die and the inside blank holder, and by the action of the punch is drawn into the form of increased depth shown at (*d*). Another and similar set of dies may then be employed to reduce the diameter and still further increase the length, the operation being repeated in stages until the required result is obtained. Sheet metal, whether steel, brass, copper or aluminium, is now supplied in qualities which will draw to great depths, and Fig. 494 (*e*), exhibits the successive stages in the sequence of operations for producing the deep vessel, A, from the circular blank, B. The first operation 1, is that of blanking and drawing; 2, 3, 4 and 5 are re-drawing or reducing, and 6 is that of sizing or finishing, the latter being finally resorted to when great accuracy in diameter is required. The "sizing" punch and die are usually of the "solid-bottomed" variety, and the operation more nearly resembles stamping, being as a matter of fact, frequently performed in a drop press. The different stages in drawing a canister 2 inches inside diameter and 4 inches high, from very soft, cold rolled sheet steel $\frac{1}{16}$ inch thick, are illustrated in Fig. 495. The first operation (1), of blanking and drawing is performed on a double-acting press by means of the dies shown at (*a*). The second operation (2), for which the dies are shown at (*b*), reduces the diameter and increases the length. The air vent to provide for the escape of air through the drawing punch will be noticed. This is an important point, and when neglected is often the cause of serious trouble. The third operation (3), is again double-acting, the dies (*c*) being constructed with an inside blank holder, as previously explained. The fourth and fifth re-drawing operations (4) and (5), are carried out by means of single-action "push-through" dies (*d*) and (*e*), as is also the final or "sizing" operation (6), for which the dies are shown at (*f*). During the progress of the work the shell is annealed four times, and when drawing, a thin mixture of lard oil and white lead is employed as a lubricant.

The design and construction of the machine itself has been much improved of late, so that it is now possible to draw at one operation articles which under the older methods required from 5 to 20 stages. This is largely due to the application of the toggle mechanism for operating the blank holder. Fig. 496 illustrates an example of a *toggle drawing press* made by Messrs.

Taylor and Challen, Ltd., of Birmingham, a firm which occupies a unique position in regard to this class of work. A crankshaft driven by powerful gearing, runs in bearings at the top of

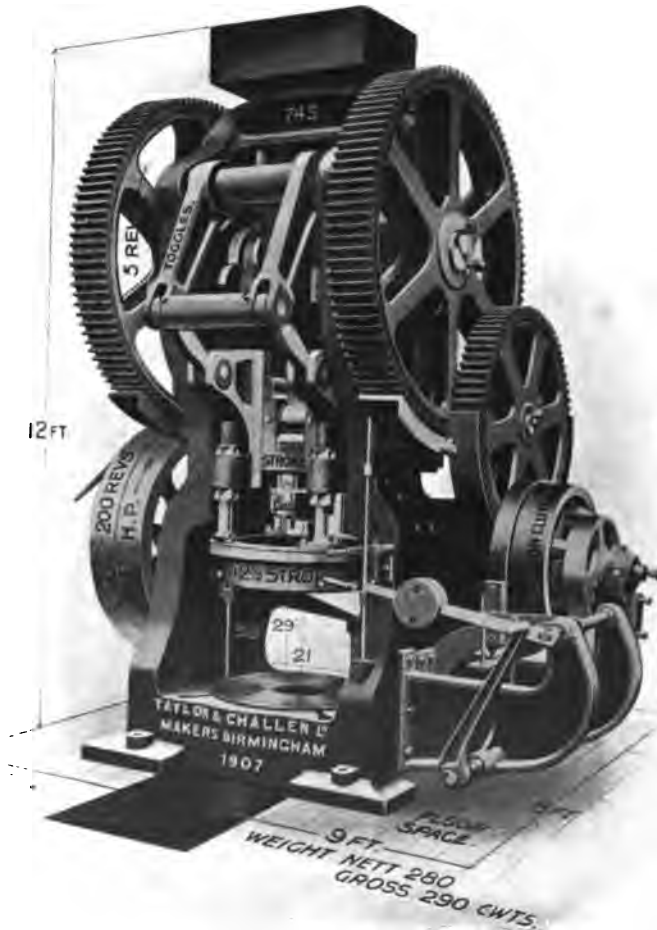

FIG. 496.—Toggle Drawing Press.

the frame, which is cast solid in one piece to give great strength and rigidity. From the crank at the centre of the shaft, a connecting rod imparts the necessary length of stroke to the plunger or inner slide for carrying the punch. This passes through, and is guided in a sliding frame B (Fig. 497), which moves

in planed slides formed in the vertical sides of the main casting C. To the frame, the blank holder, D, is attached by means of adjusting screws and nuts. The frame, or outer slide, is counter-balanced by weights, which rise and fall on a guide at the top of the machine, as seen in Figs. 496 and 499. Pressure is exerted on the blank by the toggle mechanism, which is in duplicate, in order to keep the point of application of the stress close to the side of the frame. The arrangement is shown in

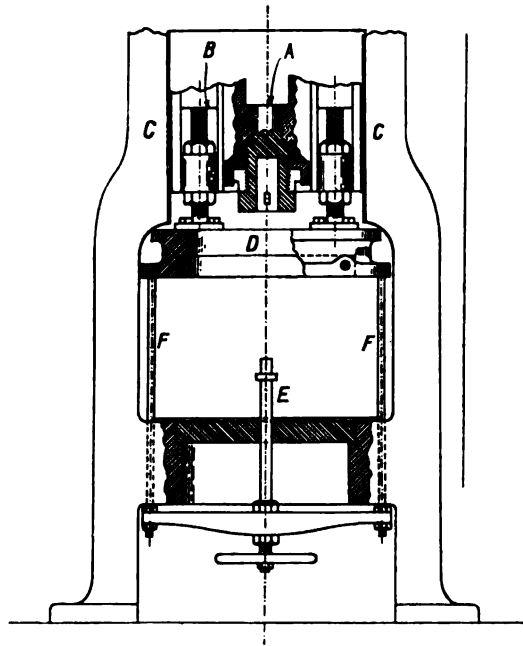

FIG. 497.—Detail of Toggle Drawing Press.

detail in Fig. 498. The toggles are worked by cams, G, which are solid with the main shaft, one on each side of the central crank. The shape of the cam is designed to give a "dwell" during rather more than a quarter of the revolution, which renders it possible to get a uniform pressure on the blank during that time, and constitutes the important feature of this type of press. The toggle levers, H, work on fulcrum pins, F, attached to the frame, and each carries at its inner end a smooth friction roller, J, which bears against the cam. The ends of the long

arms, A, are connected by links, AB, to the outer slide, and the toggle mechanism thus consists of the members, FA, AB. For a movement EE' imparted by the cam to the inner end of the toggle lever, the end of the long arm travels over AA', and the

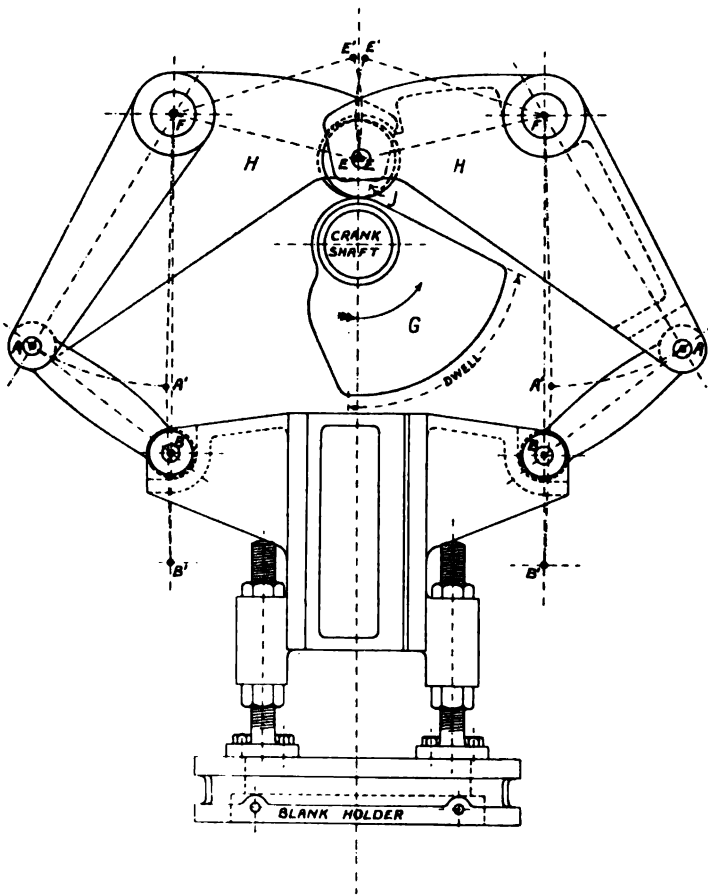

FIG. 498.—Toggle Mechanism for Drawing Press.

outer slide is depressed from B to B'. It will be seen that as the blank holder nears its lowest position, a very large movement of E and A produces only a very minute movement of B. The pressure on the cam rollers is therefore enormously multiplied at B, but the heavy pressure which is necessary to hold the blank is transmitted through the straightened toggles direct to

the frame of the machine, and does not come upon the revolving parts, thus relieving the bearings of the friction and consequent wear due to holding the blank. To place the machine entirely

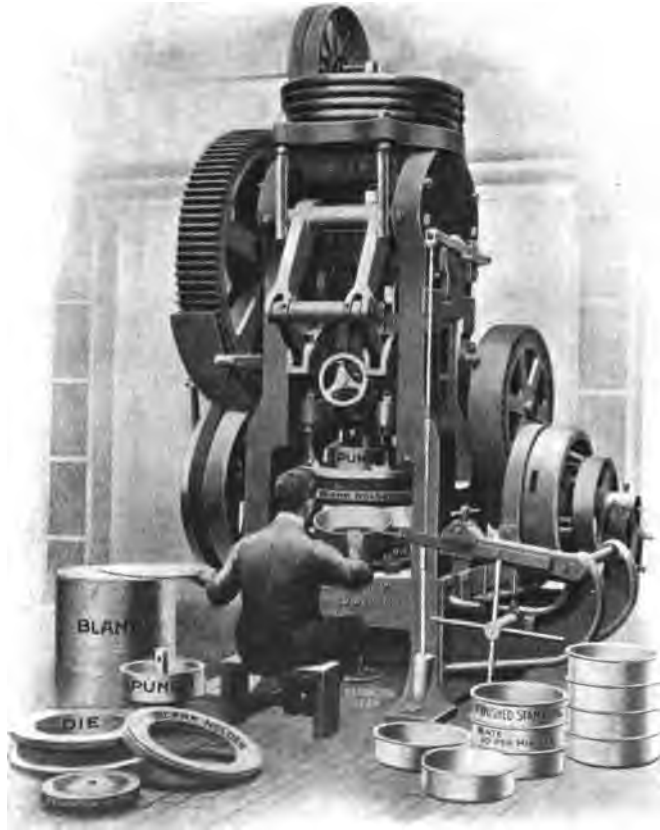

FIG. 499.—Operator Stamping Pans 18 inches diameter, $4\frac{1}{2}$ inches deep, and $\frac{1}{8}$ inch thick.

under control of the operator, it is driven through a special form of friction clutch and stop motion on the back shaft, causing the press to make one revolution and then stop at the top of the stroke to ensure safety. The clutch starting lever is placed in a horizontal position on the right-hand side of the machine, and

the pressure on the friction clutch required to drive the press is automatically derived from the machine itself during the downward stroke of the slides. In case of emergency, or when tool setting, the operator may instantaneously stop all downward movements of the press by the vertical hand lever on the right. The illustration, Fig. 499, shows the press operator engaged in stamping articles 18 inches diameter and $4\frac{1}{2}$ inches deep from mild steel blanks 26 inches diameter and $\frac{3}{8}$ inch thick. The work is ejected automatically from the dies during the upstroke after stamping, by means of an adjustable extractor, E, coupled to the blank holder slide by two vertical tension rods, F, in such a manner as to be capable of easy removal when push-through dies are in use, as will be seen from Fig. 497. In some instances, the ejector is actuated by a cam on the end of the crankshaft, or the stamping may be extracted from the die by a "stripper," which is raised during the upstroke by springs contained in pockets cast in the lower die block. An ejector or "knock-out," must also be employed with "solid-bottom" dies for producing articles

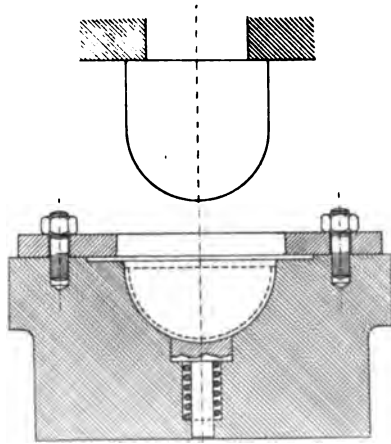

FIG. 500.—Solid Bottom Dies for Stamping Bowl.

having generally the form of a hemisphere or bowl, an example of which is given in Fig. 500. The range of work for which the drawing press is adapted is extremely wide, embracing domestic ironmongery, tin, brass and copper goods and cooking utensils of all kinds, bowls, pans, kettles, trays, brackets, boxes, scoops, shovels, lamps, reflectors, burners, cartridge cases, ferrules, watch cases, etc. A few examples from information supplied by Messrs. Taylor and Challen, are shown in Fig. 501. One of the most interesting and remarkable examples of drawing which could be referred to occurs in the manufacture of large cartridge cases, an account of which will be found in the *Proceedings of the Inst. Mechanical Engineers*, Vol. 4, 1905. The

cartridge case referred to for a British 6-inch quick-firing gun, is 16 inches long, tapering from 7 inches diameter at the breech end

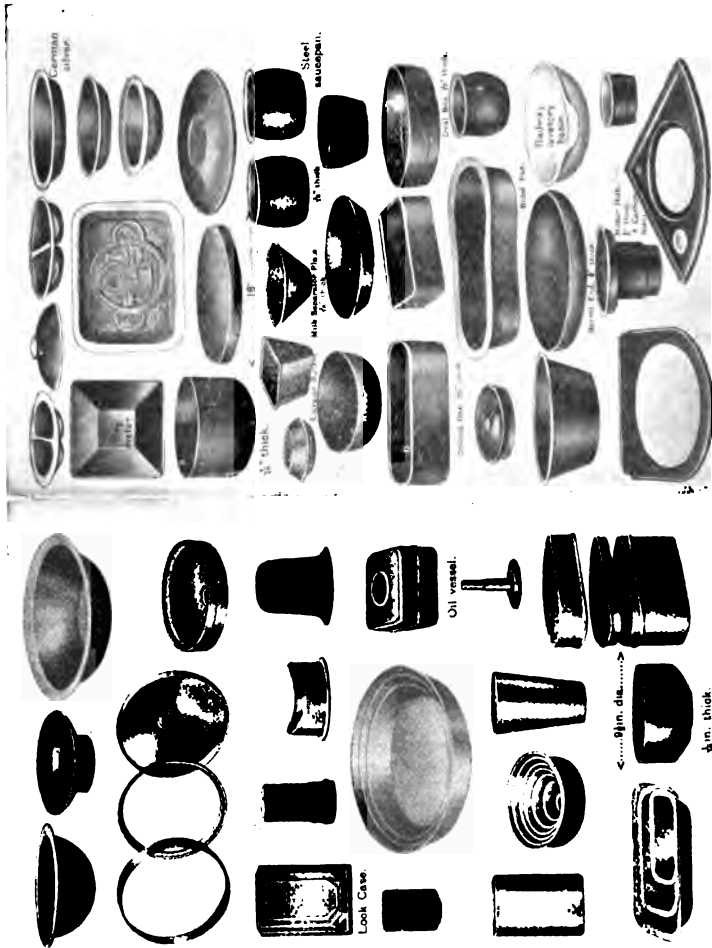

FIG. 501.—Examples of Work done in Drawing Press.

to $6\frac{1}{2}$ inches at the muzzle end. This is produced from a disc of brass $12\frac{5}{8}$ inches diameter by $\frac{3}{4}$ inch thick, weighing $28\frac{3}{4}$ lbs., by successive cupping, drawing, and indenting, with annealing at frequent intervals. The total pressure for cupping reaches

158 tons, whilst for drawing it is gradually reduced from 140 tons for the first, down to 40 tons for the eight, and last draw.

Coining and Embossing.—Another operation performed in a press is that of minting or coining for stamping pieces of money, medals, etc. This, however, differs essentially from the process of drawing just described. In coining, the two dies, representing the obverse and reverse of the piece, are in relief, and as a rule, have totally different images. The disc of metal to be operated upon is placed in a strong ring, into which also each of the dies enters for a short distance before pressure is applied, Fig. 502. The metal, being thus prevented from flowing outwards in a radial direction, retains its truly circular form and is constrained to fill up the smallest depressions in the dies, and a sharp impression results. It is a practical everyday requirement that it should be possible to place a number of the same coins one upon the other so as to form a roll, which cannot be done unless the image is everywhere lower than the rim round the edge of the coin. This restriction does not apply to a medal, the image on which is usually of much greater depth, and may therefore require greater pressure for its production, or the same result may be reached in two or more stages, with intermediate annealing.

The coin of the realm is "struck" at one pressing, the total force applied being about 60 tons for a sovereign, 100 tons for half-a-crown, and 40 tons for a halfpenny. To obtain this highly-concentrated pressure, acting however, through a very short stroke, a press of a special type is employed, the mechanism of which is shown diagrammatically in Fig. 503, I. Here *a* and *b*, are the upper and lower dies respectively, with the ring piece *c*, carrying the coin *d*, between them. The two parts of the mechanism *e* and *f*, form a toggle driven by the lever *g*, and connecting rod *h*, from the continuously revolving crankshaft of the machine. It will be noticed that for a complete stroke of the end of the lever *g*, a very small movement *R*, is imparted to the die. The mechanical advantage of the combination is therefore very

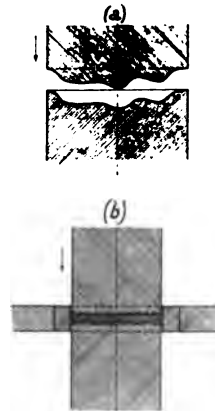

FIG. 502.—Principle of Coining.

great, enabling a considerable pressure to be exerted through a small space. Further, it is a well-known property of the toggle mechanism that the mechanical advantage increases, at first slowly, but very rapidly indeed as the two parts come nearly into line. This is shown in the outline diagram II, where the stroke of the driving lever g , has been divided into four equal parts. It is then seen that a movement a_1 is imparted to the die during the first quarter of the stroke or from 0 to $\frac{1}{4}$, whereas

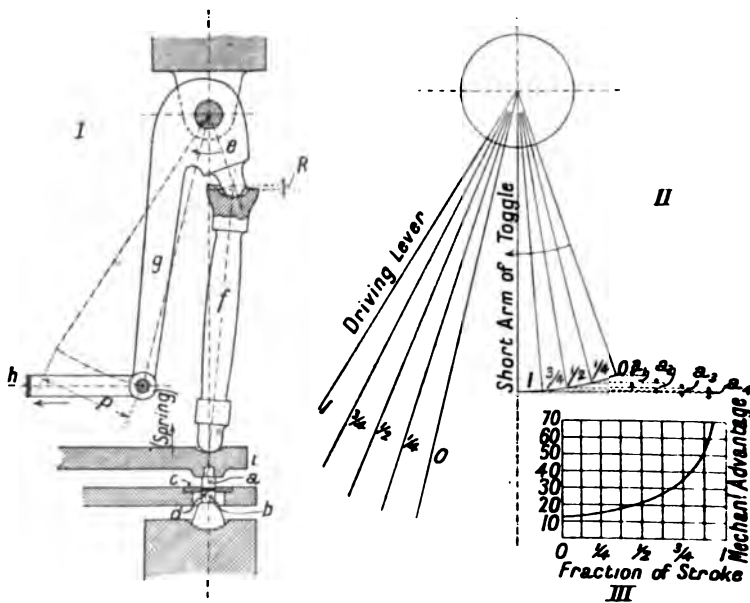

FIG. 503.—Mechanism of Coining Press.

for the same distance traversed by the end of the lever g during the last quarter, *i.e.*, from $\frac{3}{4}$ to 1, the movement of the dies is reduced to the exceedingly small amount a_4 . The resulting increase in mechanical advantage has been plotted as a curve in the diagram III. The part i , carrying the upper die, is capable of a slight amount of vertical movement, and is pressed upwards by powerful springs with sufficient force to keep the two members of the toggle always in contact. The press is fitted with an automatic feed for the supply of the discs or blanks, which are produced in a separate machine, and also with a self-acting stripping or releasing device for the delivery of the finished pieces.

BOOKS OF REFERENCE.

FOR an extended treatment of the various subjects comprised in the present work, the following may be consulted :—

General Reference.—Frequent articles bearing upon practical operations in the foundry, smithy, and workshop.

The Engineer.

Engineering.

Mechanical Engineer.

Mechanical World.

Machinery.

Preparation and Properties of Materials, including Chemistry and Metallurgy, Iron and Steel, Non-ferrous Metals, Alloys, Metallography, etc.

Rhead's Metallurgy (Longmans), 3s. 6d.

Turner's Metallurgy of Iron (Griffin), 16s.

Harbord's Metallurgy of Steel (Griffin), 25s.

Sexton's Metallurgy of Iron and Steel (Scient. Pub. Co.), 16s.

Stansbie's Iron and Steel (Constable), 6s.

Sexton's Alloys (Scient. Pub. Co.), 7s. 6d.

Kershaw's Electro-Metallurgy (Constable), 6s.

Primrose's Metallography (Scient. Pub. Co.), 3s. 6d.

Reports to the Alloys Research Committee, Proceedings of the Institution of Mechanical Engineers, 1891, 1898, 1895, 1897, 1899, 1901, 1902, 1903, 1904, 1905, 1906, 1907, 1908, 1909, and 1910.

Timber, Stone, Brick, Cement, Concrete, Asphalt, etc

Baterden's Timber (Constable), 6s.

Munby's Chemistry and Physics of Building Materials (Constable), 6s.

Rivington's Notes on Building Construction, Part III. (Longmans), 21s.

Middleton's Building Materials (Batsford), 10s.

Oils, Lubricants, etc.

Archbutt and Deeley's Lubrication and Lubricants
(Griffin), 21s.

Preparatory Process.*Moulding and Founding.*

Horner's Practical Ironfounding (Whittaker), 3s. 6d.

Horner's Pattern-Making (Whittaker), 3s. 6d.

Horner's Foundry Plant and Machinery (*Engineering*) (a series of articles from January, 1910, to present date).

McWilliam and Longmuir's General Foundry Practice
(Griffin), 15s.

Roxburgh's General Foundry Practice (Constable), 10s. 6d.

Lineham's Mechanical Engineering (Chapman and Hall),
12s. 6d.

Forging, Drop Forging, etc.

Moore's Handbook of Practical Smithing and Forging
(Spon), 5s.

Bacon's Forge Practice (Chapman and Hall), 5s. 6d.

Horner's Die Forging and Construction of Dies
(*Engineering*), 14s.

Blacksmith Shop Practice (*Machinery*), 1s.

Machine Blacksmithing (*Machinery*), 1s.

Drop Forging (*Machinery*), 1s.

Flanging, Dishing, Drawing Sheet Metal, etc.

Woodworth's Dies for Working Sheet Metal
(Constable), 12s. 6d.

Blanking Dies (*Machinery*), 1s.

INDEX.

- ABRASIVE substances, table of hardness of, 198
Acid open-hearth process, 76
Admiralty tests for wrought iron, 55
"After-blow," 74
Air furnace, 325
Air pressure, for blast furnace, 25 ; for Bessemer converter, 70 ; for cupola, 323
Alburnum, 163
Alloy, definition of, 101 ; alloy steels, 114
Alloys, constitution of, 101 ; composition of, 151, 157, 161 ; copper-tin series, 152 ; copper-zinc series, 148 ; iron-carbon, 108 ; lead-antimony, 159 ; lead-tin, 159
Aluminium, properties and uses of, 143 ; smelting of, 146
Alundum grinding wheels, 197
American whitewood, 177
Analysis, of blast furnace gas, 29 ; coal gas, 93 ; cold blast pig iron, 38 ; chemical, of lubricating oils, 212 ; of iron castings for different purposes, 357 ; mixing by, for foundry work, 356 ; of pig iron for Bessemer process, 75 ; of pig iron for basic process, 75 ; of producer gas, 93 ; of refined metal (cast iron), 38 ; typical, of pig iron, 33 ; of Taylor-White high-speed tool steel, 116 ; of wrought iron (merchant), 56 ; of Low Moor iron, 56
Angle smithing, 512
Angle, tee and channel sections, rolling, 570 ; welding, 513
Animal oils, 224
Annealing, theory of, 126 ; copper and brass, 127 ; furnace, 127 ; steel castings, 127 ; wire, 577
Annual rings in timber, 162
Antifriction metal, 160
Antimony, properties and uses of, 146
Anvil, English, 424 ; French, 424
-block, 424
Asbestos, varieties and uses of, 205
Ash, 179
Asphalte, 194
Aumond charger for blast furnace, 25

BABBITT metal, 160
Balata belting, 233
Bar, rolling iron or steel, 569 ; mill, or guide train, 48
Basic, Bessemer process, 72 ; open-hearth process, 82 ; steel, 60
Bauxite, 146
Bay wood, 178
Bearing metal, 160
Bedding-in, 260
Beech, 179
Bell metal, 154
Bell, moulding a, 292
Belting, balata, 233 ; canvas, 232 ; cotton, 232 ; double, 229 ; Gandy, 232 ; indiarubber, 233 ; leather, 228 ; textile, 232
Belt-making, process of, 228
Bench moulding, 253
Bending, in forging, examples of, 475 ; hand power tool for, 478 ; lever and roller for, 476 ; press or "Bull-dozer," 560 ; scroll, 477 ; table, 476, 507 ; tests, 55 ; under steam hammer, 561
Bent crank, forging a, 517
Bessemer, converter, 66 ; process, working of, 66 ; ladle, 72, 343 ; pig, 72, 75 ; steel works plant, 68
Best, best best, and treble best iron, 43
Best Yorkshire iron, 43
Billets for rolling, 94
Bitumen, 194
Black wash for cores, etc., 256

- Blast for cupola, 317
 Blast furnace, description of, 16 ;
 charging, 26 ; gas, analysis of,
 29 ; working of, 27
 Blast main, 21, 26
 Blister steel, 63
 Block, anvil, 424 ; swage, 429 ;
 V, 527
 Blocks for bending under steam
 hammer, 560
 Bloom, puddled, 44
 Blow, Bessemer, method of con-
 ducting, 71
 Blow holes in casting, 347
 Blower, Roots', 322, 418
 Blowing engines, blast furnace,
 24 ; Bessemer, 70
 Blue bricks, Staffordshire, 186
 Blue shortness, of steel, 59
 Board stamp, 441
 Bolt, forging a, 492
 Bolt and nut forging machine
 (Horsfall's), 554
 Bonvillain system of moulding,
 379 ; examples of, 383
 Borax, use of, 482
 Boshes, of blast furnace, 17
 Boss, methods of forging a, 497
 Box lifter moulding machine, 365
 Box, three part, 262
 Boxes or flasks, for moulding, 250
 Boxwood, 180
 Brass, composition of, 148, 151 ;
 ductility of, 149 ; freezing point
 curve, 149 ; influence of im-
 purities, 150 ; naval, 150 ; pro-
 perties and strength of, 149 ;
 white, 160
 Breaking piece, for rolls, 566
 Brickmaking, 186
 Bricks, fire, 186
 Bricks, glazed, 186 ; common red,
 186 ; Staffordshire blue, 186
 Brinell's test for hardness, 8
 Britannia metal, 158
 Bronze, or gun metal, 152 ; alu-
 minium, 155 ; coinage, 154 ;
 ductility and strength of, 153 ;
 engineers', 154 ; manganese,
 150 ; phosphor, 154 ; silicon or
 silicium, 156 ; statuary, 154
 Brown hematite, 15
 "Bull-dozer" or bending press, 560
 Burnt steel, 58
 Butt or "jump" weld, 482, 489,
 589
- Butterfly reversing valve for
 Siemens furnace, 79
- CAMBIUM, 163
 Canary wood, 177
 Canister, dies for drawing, 612
 Canvas belting, 232
 Caoutchouc, 233, *see* Indiarubber.
 Car wheels, chilled castings for, 301
 Carbon content, in cast iron, 31 ;
 influence of, on steel, 57 ; in
 wrought iron, 52
 Carbons for arc lamps, manufac-
 ture of, 602
 Carborundum, 195 ; electric fur-
 nace for manufacture of, 195
 Cartridge case, method of cupping
 and drawing, 617
 Case hardening, or carbonising,
 127
 Cast iron, analysis of, 33 ; carbon
 in, 31 ; cold blast, 17 ; crystal-
 lisation of, 243 ; malleable, 337 ;
 manganese in, 34 ; phosphorus
 in, 34 ; pig, grading or number-
 ing, 31 ; properties of, 32 ;
 result of remelting, 354 ; silicon
 in, 34 ; sulphur in, 34
 Casting, Die, 408
 Casting pit, Bessemer, 68
 Castings, annealing steel, 127, 353 ;
 blowholes in, 347 ; chilled, for
 car wheels, 303 ; chilled for rolls,
 305 ; cleaning and fettling, 344 ;
 contraction of, 238 ; defects in,
 347 ; honeycombing in, 348 ;
 iron, analysis of, for different
 purposes, 357 ; pickling, 346 ;
 porous, remedy for, 349 ; shrink-
 age and warping of, 238 ; steel,
 production of, 334 ; steel, ex-
 amples of moulding, 349 ; use
 of angle brackets in, 351 ; scabs
 on, 347 ; shrink holes in, 352 ;
 spongy, cause of, 349 ; use of
 steel scrap in, 354
 Cement, Portland, 193
 Cementation process, description
 of, 61
 Cementite, 109
 Chain making, 485
 Chaplets, 258
 Charge, blast furnace, 27
 Charging machine for steel fur-
 nace, 82

- Charging, mechanical, for blast furnace, 26
 Charging platform for cupola, 317
 Chilled castings for car wheels, 303; for rolls, 305
 Chills, core, 306; use of, to obtain soundness, 307
 Chisels, smith's, 426
 Chrome, leather, 226; steel, 114; nickel steel, 115; -vanadium steel, 115
 Cinder notch, 16
 Clay ironstone ore, 16
 Clay, origin and composition of, 185; china, 187; puddle, 187
 Cleaning and fettling castings, 344
 Cleveland ironstone, 16
 "Cliché" process of moulding, 385
 Coal gas, analysis of, 93
 Cod, in moulding, 264
 Coining press, 619
 Cold blast iron, 17
 Cold drawn tubes, 590
 Cold shortness, in wrought iron, 52
 Cold shut, in casting, 349
 Colours for tempering, table of, 122
 Commercial varieties of cast iron, 31
 Composition of copper-tin alloys, 157; copper-zinc alloys, 151; various alloys, 161
 Concrete, reinforced, 194
 Conductivity, electrical, 5; for heat, 5
 Connecting rod, forging a, 519, 544
 Constantan, 156
 Contraction of castings, table of, 238; effects of unequal, examples of, 238
 Converter, Bessemer, description of, 66; side-blown, 334; "Stock," 335; Thomas-Gilchrist, or basic, 72
 Cooling of castings, effects of, 238; steel ingot, 95, 245
 Cope, in moulding, 260
 Copper, electro-deposited, 137; properties and uses of, 130; smelting of, 130; -tin alloys, 152; tubes, manufacture of, 137, 589; -zinc alloys, 148
 Core bar, 258; box, 256; chills, 306; dry sand, 256; false, 263; green sand, 270; -iron, 258; loam, 270; -making machine, plunger type, 406; -making machine, sausage type, 407; -print, 257; sand, 256
 Cores, drying, 256
 Corrugated iron, 140
 Corundum, 195
 Cotton belting, 232
 Cowper's hot blast stove, 23
 Crane, ingot stripping, 69; ladle, 69, 343
 Crank, forging a bent, 517
 Crankshaft, forging a, 515, 541; for motor car engine, 515
 Crown glass, 207
 Crucible furnace, Brayshaw's gas fired, 331; for steel, 64; for brass, 326; tilting, for brass, 329
 Crystallisation, of cast iron, 243; wrought iron, 55
 Crystolon grinding wheels, 197
 Cup and cone for charging blast furnace, 21
 Cupola, foundry, 313; blower for, 317; charging, 315; Thwaites', 313
 Cupro-nickel, 156
 Cylinder, moulding a, in dry sand, 276; in loam, 294
 Cylinder cover, moulding a, 260, 262
 Cylinder oil, 222
 DANDY, of puddling furnace, 42
 Danzig fir, 176
 Defects, in iron castings, 347; in steel castings, 349; in timber, 171
 Delta metal, 150
 Depth, of chill, 303; of case (case-hardening), 127
 Die-casting, examples of, 408; machine, 409
 Die sinking, 548
 Die stamping or drop forging, 547; examples of, 549
 Dies for stamping, circular flanges, 551; draw hooks, 554; engineer's spanner, 549; eyebolt, 553; small levers, 551
 Dies, stripping, 553
 Dies, wire-drawing, 578; mechanically adjusted, 579

- Dishing metal plates, hydraulic press for, 605
 Dolomite or magnesian limestone, 190
 Double belting, 229
 Double-webbed crank, forging a, 541, 546
 Douglas fir, 180
 Downcomer, for blast furnace, 19
 Drawback, in moulding, 264
 Drawbench, for rod or tubes, 581; for wire, 582
 Drawing down, in forging, 474
 Drawing machine for wire, Crossley's, 582; Glover's, 584; multiple or continuous, 584
 Drawing sheet metal, Taylor and Challen's toggle press for, 612; dies for canisters, etc., 612
 Draw plates and dies for wire, 578
 Drifting tests for wrought iron, 55
 Drifts, smith's, 478
 Drop forging or stamping, process of, 547; examples of, 549
 Drop hammer, friction, 438; board stamp, 441; lifter for, 438
 Dry sand core, 256; moulding, 247
 Drying cores, 256
 Ductility, definition of, 12; order of (wire-drawing), 12
 Duramen, or heartwood, 163

 EBONITE, 235
 Elasticity, 6; limit of, 6; modulus of, 6
 Electrical conductivity of metals, 5
 Electric charging machine for open-hearth furnace, Wellman's, 82
 Electric furnace, for manufacture of carborundum, 195; smelting furnaces, types of, 97
 Electro-thermic manufacture of steel, 96
 Electro-zincing, 140
 Elements, occurrence of, in nature, 14
 Elm, 179, 180
 Elongation, as measure of ductility, 14
 Emery, 195; wheels, manufacture of, 199
 Engine, blowing, for blast furnace, 24; Bessemer blowing, 70; reversing rolling mill, 50

 Engineer's bronze, 154
 Eutectic, 104
 Extruded metal rod, 602
 Eyebolt, forging an, 504; stamping an, 553

 FACING sand, in moulding, 253
 Faggot or pile, for rolling, 46
 False core, 263
 Fan, for blowing cupola, or smith's fire, 317; Sturtevant, 322; theory of the, 319
 "Fatigue" resistance of iron and steel, comparative, 59
 Feeding gate, in moulding, 253
 Ferrite, 109
 Ferro-manganese, 34, 80, 95
 Ferro-silicon, 95
 Fettling and cleaning castings, 344
 Fibre, of wrought iron, 43, 55
 Fir, Danzig, 175; Douglas, 180; Scotch, 175; white, or spruce, 176
 Fire, smith's, 413
 Firebricks, 186
 Fireclay, 186
 Flanging, plate by hand, process of, 603; press, hydraulic, 604
 Flash point, of oils, 218; Gray's apparatus for, 218
 Flasks or boxes, for moulding, 250
 Flatters, smith's, 428
 Fluid-compressed steel, 96
 Fluidity, 5
 Flux, for blast furnace, 16; for cupola, 317; for welding, 481
 Flywheel, moulding a, 288
 Foot hammer, or "Oliver," 434
 Forge, 44; arrangement of, 413; furnace for, 419; hammer, 461, 520; valve gear for, 463, 521; train, or puddle rolls, 45
 Forging, a bent crank, 517; big end strap for connecting rod, 519; bolt, 492; bosses on links and levers, 497; cook piece, 494; connecting rod, 519, 544; drop, or stamping, 547; double-throw crankshaft, 541; steam hammer for, 546; an eyebolt, 504; eye end for tie rod, 495; a forked end, 500; hand, simple examples of, 492; a hook, 502; hoop, 506; machine, Ryder's, 444; Horsfall's bolt and nut, 554;

- examples of work by, 559 ; operations in, classification of, 472 ; press, hydraulic, advantages of, 526 ; types of, 527 ; 60-ton rapid action, 535 ; 4,000-ton, at Messrs. Vickers' Works, Sheffield, 535 ; a slide valve bridge, 512 ; small crankshaft, 515 ; solid tyre, 508 ; by stamping, examples of, 549 ; a steel shaft, 535, 541 ; T end, 499 ; tools used in, 422 ; under steam hammer, examples of, 468, 497, 505
- Forgings, hammered scrap, 540 ; production of, in iron and steel, 544 ; marine connecting rod, 544 ; shaft, 541
- Founding, principles of, 237
- Foundry, arrangement of, 308 ; brass, 326 ; cupola, 313 ; iron, 309 ; ladles, types of, 341 ; mixtures, 354 ; rattler, or tumbling barrel, 345 ; water do., 345
- Four-part box, examples of use of, 267
- Fracture, appearance of, 31
- Freezing point curves for alloy, 104, 105 ; copper-tin series, 153 ; copper-zinc, 149 ; iron-carbon system, 110 ; lead-antimony, 159 ; lead-tin, 159 ; for salt solutions, 103, 104 ; solid solutions, 105 ; for water, 102
- Frick's induction furnace, 98
- Friction drop stamp, 437
- Frodingham Steel Works, 100-ton furnace at, 88
- Fullers, smith's, 427
- Furnace, arc, Stassano's, 97 ; annealing, 127 ; balling, or re-heating, 419 ; blast, 16 ; case-hardening, 127 ; cementation, 61 ; continuous-working steel, Talbot's, 86 ; crucible, for brass, 326 ; crucible for steel, 64 ; electric, varieties of, for steel manufacture, 96 ; for manufacture of carborundum, 195 ; forge, 419 ; gas, Brayshaw's, 331 ; for hardening, 121 ; heating, for forge, 419 ; induction, Frick's, 98 ; puddling, 38 ; regenerative, 76 ; re-heating, 419 ; resistance, Héroult's, 98 ; reverberatory, for copper smelting, 131 ; salt bath, for tool steel, 124 ; scrap heating, 422 ; Siemens open-hearth steel, 76 ; Talbot's continuous steel, 86 ; tilting or rolling, for steel, 85 ; twin, for high speed steel, 125
- Fusibility, methods depending on property of, 237
- Fusible metal, 159
- GAGGER, in moulding, 260, 275
- Galvanised iron, 140
- Galvanising, 140
- Gandy belting, 232
- Gangue, 16
- Ganister, 68
- Gas engine oil, 224
- Gas-fired crucible furnace, Brayshaw's, 331
- Gas furnace, 76, 121, 125, 331
- Gas, producer, analysis of, 93
- Gas producer, Hilger, 92 ; Siemens 88 ; Wilson, 89
- Gates, in moulding, 252 ; pouring, skimming, feeding, etc., 253
- Gauge, pressure, for fan or blower, 324
- Gear moulding machine, 399
- German silver, 156
- Glass, crown, flint and plate, 207 ; manufacture of, 207 ; sheet, 208 ; tubing, 208
- Glazed bricks, 186
- Grade of grinding wheels, 199 ; grain of do., 198
- Granite, composition and uses of, 184
- Gray's flash-point apparatus, 218
- Greenheart, 178
- Green sand, core, 270 ; moulding, 249
- Grey cast iron, 31, 112
- Grinding wheels, alundum 197 ; carborundum, 195 ; characteristics of, 197 ; crystolon, 197 ; emery, 195 ; grade or hardness of, 199 ; grade scale of, 201 ; grain or fineness of, 198 ; speed of, 203 ; table of grain and grade for different purposes, 202 ; vitrified, 200
- Grindstones, 189
- Grooves in rolls, forms of, 568

- Gumming of oils, test for, 214
 Guide train or bar mill, 48
 Gutta percha, collection and uses of, 235
- HAMMER**, drop, 437; foot, or "Oliver," 434; friction drop, or stamp, 441; hand, 422; lifter for drop, 438; motor-driven power, 441; mechanical, Blacker's, parallel, 434; pneumatic, 449; power, 437; shingling, 42; sledge, 423; spring, Shaw's, 447; spring lever, 448; steam, 454; force of blow of, 455; rating of, 457; Rigby type, 461; self-acting gear for, 465; with top steam, 454
 "Hammered scrap," forgings, 540
 Hand forging, simple examples of, 492
 Hand hammer, 422
 Hand power, bending tool, for smith, 478; welding machine, Nicholson's, 482
 Hand press moulding machine, or "squeezer," 373
 Hand shank ladle, for foundry, 341
 Hardening carbon steel, 123; high speed steel, 124; steel, theory of, 125
 Hardness, definition, 7; of abrasive substances, table of, 198; number, Brinell's, 8; order of, of common metals, 11; scale of, Mohs', 7; scales, comparison of, 11; testing machine, Brinell's, 8; Shore's scleroscope, 10
 Harveyised steel, 115
 Head, on casting, 259
 Hearth, smith's, 413
 Heartwood, 163
 Heat, conductivity for, 5; specific, 4
 Heat treatment of steel, 120
 Hematite ore, red, 15; brown, 15
 Heroult's resistance furnace, 98
 Hickory, 179
 Hide, section of, 225
 High speed steel, analysis of, 116; hardening, 124; properties of, 123
 Hones and oilstones, 203
 Honeycombing, in castings, 348
 Hook, forging a, 502
- Hoop, forging a, 506
 Hornbeam, 180
 Hot blast, advantages of, 21; stove, Cowper's, 23
 Hot saw, for smithy, 467
 Hydraulic, forging press, 526, *see* Forging press; flanging press, 604; leathers, 230; moulding machine, 388; packing, 230; press, shape of cylinder for, 244; casting a cylinder for, 259; for dishing metal plates, 605; for squirting lead pipe, 596
 Hydrometer, or densimeter, 212; Beaumé's, 213
- IMPURITIES** in iron, 33
 Indentation test for hardness, Brinell's, 8
 Indiarubber or caoutchouc, 233; collecting and dissolving, 234; vulcanising, 235; belting, 233
 Ingot stripping crane, 69
 Invar, 114
 Iron-best, best best, and treble best, 43
 Iron, best Yorkshire, 43
 Iron, cast, 31, 238; mixture, of, 354; varieties of, 31; castings, analysis of, for different purposes, 357; corrugated, 140; foundry, typical, 308; galvanised, 140; Low Moor, manufacture of, 35; merchant, 43; ores of, 15; pig, 31, *see* Pig iron; smelting of, 16; Staffordshire, 43; wrought, production and properties of, 35
- JARRAH**, 179
 Joist and rail sections, rolling, 570, 573
 "Jumping up," in forging, examples of, 472
- KARRI**, 179
 Kauri pine, 176
- LADLE**, Bessemer, 69, 343; crane, 341; foundry, 341; hand shank, 341; self-skimming, 342; steel casting, 343

- Lapweld or scarf in forging, 482
 Larch, 176
 Lathe bed, moulding, 266
 Lead and antimony, alloys of, 159 ;
 covering for electric cables, 602 ;
 hydraulic press for covering
 cable with, 602 ; milled, 141 ;
 pipe, manufacture of, 141,
 596 ; properties and uses of,
 141 ; red, 142 ; sheet, 141 ;
 smelting of, 142 ; and tin, alloys
 of, 158 ; white, 142
 Leather belting, 227 ; chrome,
 226 ; hydraulic, manufacture
 of, 230 ; raw hide, 232 ; tanning
 of, 226 ; varieties of, 227 ;
 wash-, 231 ; white, 227
 Leeds Steel Works, basic Bessemer
 plant at, 74 ; method of rolling
 tram rail, 574
 Lever, forging a, 497 ; stamping a
 two-armed, 551 ; and roller for
 bending, 476
 Lift for blast furnace, 26
 Lifter for drop hammer, 438
 Lignum vitæ, 178
 Lime, or linden, 177
 Lime, burning, 192 ; slaked, 192
 Limestone, 189 ; magnesian, 190
 Lining for converter, Bessemer,
 68 ; basic, 73
 Liquid shrinkage in casting, 238
 Loam board, or strickle, 270 ; core
 270 ; composition of, 289 ;
 moulding, 247, 270, 289 ; pattern
 270, 290
 Low Moor Ironworks, plant at, 35,
 38, 50
 Lubricants, classification of, 210 ;
 testing, 212
 Lubricating oils, table of proper-
 ties of, 224
- MACHINE**, charging, for open-
 hearth steel furnace, Wellman's,
 82 ; core-making, 406 ; coining,
 619 ; die casting, 408 ; flanging,
 604 ; forging, Horsfall's, 554 ;
 Ryder's, 444 ; moulding, 364,
see Moulding machines ; Bon-
 villain's system of, 379 ; diffi-
 culties in, 394 ; examples of,
 367, 370, 373, 376, 389, 394 ; jar-
 ramming system of, 394 ; weld-
 ing, Nicholson's, 482
- Magnesian, limestone or dolomite,
 190
 Magnetic iron ore, 15
 Magnetic properties, 5
 Magnolia metal, 161
 Mahogany, Honduras, 178 ;
 Spanish, 178
 Malleability, metals in order of,
 by hammering, 12 ; by rolling, 12
 Malleable cast iron, 337
 Manganese, bronze, 150 ; effect of,
 in cast iron, 34 ; in steel, 72, 116 ;
 steel, 116
 Manganin, 156
 Mannesmann process for tube
 making, 593
 Maple, 180, 181
 Marble, 190
 Martensite, 109
 Materials, properties of, 4
 Mechanical charging of blast fur-
 nace, 26 ; testing of oils, 218
 Medullary rays, 164
 Melting metals, methods of, 311
 Melting points of metals, 13
 Memel timber, 176
 Metal mixer, 70
 Metal bell, 154 ; delta, 150 ; gun,
 154 ; Muntz-, 149 ; speculum,
 154 ; white, 160
 Metallography, 108, 113
 Metals, melting, methods of, 311 ;
 melting point of, 13 ; properties
 of, table of, 13 ; weight of, 13
 Microscopic examination of metals,
 108
 Mill, cogging, 45, 94 ; plate, at
 Low Moor, 50 ; rolling, 44, 562 ;
 reversing, 50, 567 ; train, 46
 Mineral oils for lubricating pur-
 poses, 222
 Minting, toggle press for, 619
 Mixer, metal, 70
 Mixing by analysis for foundry
 work, 356
 Mixtures, foundry, 354 ; for iron
 castings, 357 ; calculation of, 356
 Mora, 178
 Motor-driven power hammer,
 Massey's, 441
 Mottled cast iron, 31
 Mould, arrangement of, 252 ;
 ingot, for crucible cast steel, 65 ;
 for Bessemer or Siemens steel,
 69, 80, 95 ; pot, in foundry
 work, 267

- Moulder's tools, 247
- Moulding back standard for vertical engine, 281; bell in loam, 292, 293; Bonvillain system of, 379; boxes, types of, 250; cast-iron column, 274; chain wheel, 262, 270; chill, examples of, 303; "cliché" process of, 385; cylinder or pump barrel, 265, 352; examples of, in boxes, 253; dry sand, 247, 250; flanged cylinder in loam, 293; gas or water pipe with loam pattern, 270; green sand, 249, 260; jar-ramming, method of, 394; lathe bed, 266; large hemispherical pan in loam, 290; machine, varieties of, 364; box lifting type, 365; hand press, 373; hydraulic, 388; jar-ramming type, 394; pneumatic, 376; rock-over drop, 367; stripping plate, 371; turn-over table, 366; wheel or gear, 399; pipes, pipe bends, etc. from loam patterns, 270, 297; main casting for steam pump, 277; open sand, 249; plate, 360; pulleys and rope wheels, 260, 266, 269, 288; reverse, 285; steam cylinder in dry sand, 276; loam, 294; wheels by machine, 399
- Multiple moulding, examples of, 397
- Mushet steel, 116
- Muntz metal, 149
- NAVAL brass, 150
- Nickel, alloys of, 156; -bronze, 156; properties of, 147; smelting of, 147; -steel, 114; -chrome steel, 115
- Noblin, or puddled bloom, 42
- Northern pine, 175, 181
- "Numbers" of pig iron, 32
- Nut and bolt forging machine, Horsfall's, 554; examples of work done by, 561
- OAK, 177, 180, 181
- Oils, animal, 210, 224; chemical analysis of, 212; flash-point of, 218; gas engine, 224; gumming of, test for, 214; mineral, 210, 224; properties of, table of, 224; testing of, 212; vegetable, 210, 224; viscosity of, 211
- Oil bath for quenching steel, 124, 129
- Oilstones, hones, etc., 203
- Oil testing machine, Thurston's, 219
- "Oliver," or foot hammer, 434
- Open-hearth steel process, 60, 76, 85, 93
- Open sand moulding, 249
- Operations in forging, classification of, 472
- Ore, calcining, 16, 131; copper, 130; iron, 15
- Oregon pine, 180
- PARTING sand, 253
- Pattern-making, woods used for, 180
- Pattern plate, double, and reversible, 379
- Patterns, loam, 270; metal, 361; position in mould, 259; rapping, 254; skeleton, 300; for marine engine cylinder, 302; for pipe bends, 300; for steam turbine casing, 302
- Pearlite, 109
- Petrol, 224
- Petroleum, 224
- Pewter, 158
- Phosphor bronze, 154; copper, 155; tin, 155
- Phosphorus in cast iron, 34; in steel, 60, 72; in wrought iron, 52
- Pickling castings, 346
- Pig bed, 27
- Pig iron, analysis of, for Bessemer process, 75; for basic process, 75; typical, 33; grading of, 31; impurities in, 33
- Pile or faggot, for rolling, 42, 46
- Pine, Kauri, 176, 180, 181; northern, 175, 181; Oregon, 180; pitch, 176, 180, 181; yellow, 176, 180, 181
- Pipe, moulding a, 270; bend, moulding a, 298, 300; copper, solid drawn, 589; electrically deposited, 137; gas, wrought iron, 589; lead, hydraulic press for "squirting," 596; steam, wrought iron, 589

- "Piping," in steel ingots, 95, 245
 Pitch pine, 176, 180, 181
 Pits, soaking, for steel ingots, 72, 94
 Plasticity, 7
 Plate glass, 207
 Plate mill, Low Moor Ironworks, 50
 Plate moulding, examples of, 360
 Platform for charging cupola, 317
 Platinoid, 157
 Plumbago blacking for moulds, 254
 Plumber's solder, 158
 Pneumatic hammer, 449; with separate pump, Massey's, 451; moulding machine, 376; self-acting vibrator for, 377
 Porous castings, remedy for, 349
 Portable forge, 417
 Porter for forging, 540, 543
 Portland cement, 193; stone, 190
 "Pot mould" system of moulding, 267
 Pouring gate or runner, in moulding, 252
 Pouring molten metal, 341
 Power hammer, 437; drop, 437; friction drop, 441; parallel, 435; pneumatic, 449; spring, 445
 Power ramming moulding machine, 371
 Press, bending, or "Bull-dozer," 560; flanging, 604; hydraulic forging, 526, *see* Forging press; stamping and drawing for sheet metal, 606; toggle drawing, Taylor and Challen's, 612; examples of work done by, 617; coining and embossing, 619
 Pressure gauge for fan or blower, 324
 Pressure of air, for blast furnace, 25; for Bessemer converter, 70; for cupola, 323
 Pressure plate for drawing press, 607
 Prints, core, 257
 Process of steel making, acid, 60, 66, 76; basic, 60, 72; Bessemer, 60, 66, 72; cementation, 60, 61; open-hearth, 60, 76; Siemens, 60, 76; Thomas-Gilchrist, 60, 72; Talbot continuous, 86; Stock's, 335
 Producer gas, analysis of, 93
 Projectiles, steel for, 115
 Puddled ball, 42; bar, 44; bloom or noblin, 42
 Puddling, dry, 38; wet or pig-boiling, 38; furnace, at Low Moor, 39
 Pulley, moulding a, 260, 266, 288
 Punches, smith's, 431
 Punching and drifting in forging, examples of, 478; tests for wrought iron, 55

 "QUALITY FIGURE" for iron and steel, table I., p. 117

 RABBLE, for puddling, 41
 Rail and joist sections, rolling, 569, 573
 Ram's horn test, 55
 Rapping patterns in sand, 254; rapping plates, 254
 Rating of steam hammer, 457
 Rattler or tumbling barrel, for foundry, 345; water do., 345
 Raw hide leather, 232
 Recalescence, 121
 Re-carburisation, 71, 75
 Red hardness, of high speed steel, 123
 Red lead or minium, 142
 Red shortness, in wrought iron or steel, 52
 Redwood, 175, 180, 181
 Redwood's viscosimeter, 215
 Re-entrant angles, in castings, 244
 Refinery at Low Moor Ironworks, 35
 Refining cast iron, 35
 Regenerative furnace, Siemens, 76
 Regenerators, hot blast stove, 23; Siemens furnace, 76, 79
 Reinforced concrete, 194
 Remelting cast iron, result of, 354
 Resistance furnace, Hèroult's electric, 98
 Reverse moulding, 285
 Reversible pattern plate system of moulding, 379, 383; "cliché" process, 385
 Reversing rolling mill, 50, 567
 Reversing valve, butterfly, for Siemens furnace, 79
 Rigby type of steam hammer, 461

- Risers, in moulding, 252
 Rivets, tests for, 56
 Rock-over drop moulding machine, 367
 Rolling, production of parts by, 563; mill, 562; reversing, 50, 567; plates, 50; section bars, 570; mill engines, 50
 Rolls, action of, 562; for angle, tee and channel sections, 570; cogging, 45, 94; chilled, method of casting, 305; finishing, 46, 47; form of grooves in, 568; puddle, 45; for flanged rails and joist sections, 569, 570, 573; roughing, 45, 47; train of, 564; two-high, 564; three-high, 567; for tram rails, 574
 Root's blower, 322, 418
 Rope pulley, moulding a, 269, 288
 Rubber, 233, *see* Indiarubber
 Runner or pouring gate, in moulding, 252

 SAND, for moulding, properties of, 246; dry-, 247, 253; green-, 247, 249; facing-, 253; parting-, 253; open-, 249
 Sandstone, 188, 191
 Sapwood, 163
 Saw, hot, for smithy, 467
 Scabs, in castings, 347
 Scarf or lap weld, 482, 485
 Sclerometer, 8
 Scleroscope, 10
 Scrap hammered, for shafts, 540
 Scrap-heating furnace, 422
 Scrap iron, use of in foundry, 354, 356
 Scroll bending, 477
 Section bars, cogging, 47, 571; finishing, 47, 570; rolling, 46; rolls for, 569
 Segregation in steel ingots, 95; in alloys, 107
 Self-acting gear for steam hammer, 466
 Self-skimming ladle, 342
 Shaft, small crank-, forging a, 515
 Shaft weld, 490
 Shafts, steel, forging, 541
 Sheet glass, 207
 Sheet lead, 141; -tin, or tin plate, 139; zinc, 140
 Sheet piling, method of rolling, 574
 Shingling hammer, 42, 45
 Shrink holes, in castings, 352
 Shrinkage, liquid, in casting, 238
 "Shutting" or welding, 481
 Side-blown converter, 335
 Siemens process, 60, 76
 Siemens-Martin process, 60
 Silicon, in cast iron, 34, 355; bronze, 156
 Silver grain, 164
 Single eye, forging a, 495
 Sink head, in casting, 259, 352
 Skeleton patterns for marine engine cylinders, 302; pipe bend, 300; steam turbine casing, 302
 Slag, blast furnace, 16, 29; disposal of, 29; puddling furnace, 42; mill furnace, 46; pit, Siemens furnace, 82; basic Bessemer, 75
 Slaked lime, 192
 Slate, 187; enamelled, 188
 Sledge hammer, 422
 Smelting, copper, 130; iron, 16; lead, 142; tin, 139; zinc, 141
 Smithing, angle, 512
 Smithy, or smith's shop, arrangement of, 413
 Smith's hearth or fire, blower for, 418; brick-built, 414; cast iron, 416; portable, 417; down draught, 416
 Smith's tools, chisels, 425; flatters and fullers, 427; hammers, 422; punches and drifts, 431; swages, 428; tongs, 433
 Soaking pit, 72, 94
 Soil pipe, lead, press for making, 601
 Solid drawn tubes, manufacture of, 589
 Solutions, freezing of, 103; solid, 102
 Spathic iron ore, 16
 Specific gravity, 4; specific heat, 4
 Speculum metal, 154
 Spelter, 140
 Spiegeleisen, 34, 80
 Split or fork weld, 489
 Spongy castings, cause of, 349
 Spring, or Shaw's power hammer, 445, 447; spring lever hammer, 448
 Sprues, in casting, 250, 252

- Squeezer, for expelling slag, 45
 Squirting lead pipe, hydraulic press for, 596
 Staffordshire blue bricks, 186; iron, 43
 Stamp, board, 441; friction drop, 438; steam, 466
 Stamping or drop forging, 547; dies, set of, for draw bar hooks, 554; for engineer's spanners, 549; examples of, 549
 Stamping and drawing sheet metal, 606; toggle press for, 612
 Stassano electric arc furnace, 97
 Steam cylinder, moulding in dry sand, 276; large, moulding in loam, 294
 Steam hammer, 454; force of blow of, 455; forge type, 520; forging under, examples of, 497, 505, 508, 517, 541, 544; tools for, 468; rating of, 457; Rigby type, 461; self-acting gear for, 466; top steam working, 454
 Steam stamp, Enfield pattern, 466
 Steel, acid, 68; basic, 73; Bessemer, 60, 66; blister, 63; carbon, 57; carbonising, or case-hardening, 127; castings, annealing, 127, 353; examples of, 349; casting ladle, 343; cementation, 60, 61; chrome-, 114; nickel-, 115; vanadium-, 115; classification of, 59; composition of, 108; crucible cast, 64; definition of, 57; furnace, 64, 76, 85, *see* Furnace; hard, 57; hardening of, 121; heat treatment of, 120; high speed tool, 116, 123; manganese, 116; medium, 57; mild, 57; Mushet, 116; nickel, 114; plates and bars, rolling, 94; shafts, forging, 535, 541; shear, single and double, 63; Siemens open-hearth, 60, 76; Siemens-Martin, 60; temper or carbon content of, 120; tempering, 122; Thomas, 60, 72; tungsten-, 116; Whitworth fluid-compressed, 96; works plant, basic or Thomas-Gilchrist, 72; Bessemer, 66; cementation, 61; continuous, 86; Siemens, 76
 Steels, alloy, 114
 M.T.
- Stern tube, lignum vitæ bearing for, 178
 Stock converter, for steel castings, 335
 Stone, classification of, 184; varieties and uses of, 184; durability of, 182; hardness of, 183; strength of, 183; table of properties of, 191; weight of, 184
 Stoneware, 186
 Stove, hot blast, Cowper's, 23
 Strain, 6
 Strap for big end of locomotive connecting rod, forging, 519
 Stress, 6
 Strickling or striking board, 270, 285; a pattern in loam, 271; mould for fly wheel or pulley rim, 288
 "Strip" of patterns, 264, 371
 Stripping plate moulding machine, 365, 370; Bonvillain's system, 381
 Stud weld, 490
 Sturtevant fan, 322
 Sulphur, in cast iron, 34, 355; in wrought iron, 52; in steel, 72, 82
 Supports for cores, 258
 Swage block, 429
 Swages, smith's, 428
 "Sweeping up," dished cover in green sand, 285; rim of fly wheel or rope pulley, 288
 Switchboards, marble for, 192; slate for, 188
 Sycamore, 180
- TABLE, bending, for smithwork, 476, 508
 Talbot's continuous-working steel furnace, 86
 Tanning leather, 226
 Tapping hole, of blast furnace, 17, 27; cupola, 313, 315
 Taylor-White high speed tool steel, 116
 Teak, 177, 180, 181
 Temper, or carbon content of steel, 120
 Tempering carbon steel, 122, 124; colour scale for, 122
 Tensile stress, 6
 Tests, comparative, of iron and

- steel, table of, opposite p. 117 ;
 cold bending, 55 ; drifting, 55 ;
 forge, for rolled sections, 56 ;
 hardness, 8 ; ram's horn, 55 ;
 for rivets, 56 ; for steel, 59 ; for
 wrought iron, 55
 Textile belting, 232
 Thermite welding, 145
 Thurston's oil-testing machine,
 219
 Tilting crucible furnace, 329
 Tilting or rolling furnace for steel,
 Talbot's, 86
 Timber, classification and varieties
 of, 175 ; conversion and market
 forms of, 169 ; defects in, 171 ;
 felling and seasoning, 167 ;
 preservation of, 174 ; properties
 and uses of, 162 ; shrinkage of,
 165 ; table of uses of, for dif-
 ferent purposes, 180 ; table of
 ultimate strength and weight of,
 181
 Tin and antimony, alloys of,
 158 ; and copper, 152 ; and
 lead, 158 ; properties of, 139 ;
 smelting of, 139 ; plate, or sheet
 tin, 140
 Tinner's solder, 158
 Toggle press, for coining and em-
 bossing, 619 ; for drawing sheet
 metal, 612 ; dies for, 609 ; ex-
 amples of work done by, 617
 Tongs, crucible, 329 ; smith's,
 varieties of, 433
 Tools, moulders', 247 ; smith's,
 422 ; steam hammer, 468
 Tram rails, rolling, at Leeds Steel
 Works, 574
 Tubes, butt welded, 589 ; elec-
 trically-deposited copper, 137 ;
 glass, 208 ; lap-welded, 589 ;
 Mannesmann seamless rolled,
 593 ; solid drawn, 589, 590 ;
 weldless steel, 591
 Tumbling barrel or rattler for
 foundry, 345
 Tungsten-bronze, 157 ; -steel, 116
 Turn-over board, in moulding,
 253 ; table moulding machine,
 366
 Tuyeres, blast furnace, 21 ; Besse-
 mer converter, 66, 71 ; cupola,
 313 ; smith's hearth, 414, 416,
 417
 Type metal, 159
 UPSETTING or "jumping-up" in
 forging, examples of, 472
 Uralite, 207
 V WELD or splice, 489
 Valve gear for stem hammer, 463,
 521
 Valve oil, 223
 Vanadium steel, table of properties
 of, 118, 119
 Varieties, of cast iron, 31 ; of
 leather, 227 ; of steel, 59 ; of
 stone, 182 ; of timber, 162 ; of
 wrought iron, 43
 Vegetable oils, 210, 224
 Venting moulds, 261, 271, 275 ;
 foundry floor, 247, 285
 Vibrator for pneumatic moulding
 machine, 377
 Viscosimeter, Redwood's, 215
 Viscosity of oils, 211, 215
 Vulcanising, 235
 Vulcanite, 235
 WALNUT, 180, 181
 Warping, of castings, 240, 242 ; of
 timber, 166
 Washleather, 231
 Water rattler, for foundry, 345
 Weld, in angle or tee iron, 489,
 513 ; butt, 489 ; lap or scarf,
 485 ; shaft, 490 ; V or splice,
 489
 Welded joint, forms of, 482 ;
 strength of, 489
 Welding or "shutting," 481 ;
 chain, 485 ; heat, 481 ; machine
 hand power, 482
 Weldless steel tubes, 591
 Wellman's charging machine for
 open-hearth furnace, 82
 Wheel moulding machine, for
 bevel gear, 404 ; principle of,
 399 ; floor type, 402 ; for
 helical and worm gear, 405 ;
 table type, 403
 White, brass, Parson's, 160 ; cast
 iron, 31, 33, 113 ; fir or deal,
 176 ; lead, 142 ; leather, 231 ;
 metal alloys, 158 ; wood, Ameri-
 can, 177, 180
 Whitworth fluid-compressed steel,
 96
 Wilson gas producer, 89

- "Wiping" a joint in lead pipe, 158
Wire-drawing, action of, 575 ;
continuous or multiple machine
for, 584 ; machine, Crossley's,
582 ; Glover's, 584 ; dies for,
578 ; speed of, 578
Wobblers, or coupling boxes for
rolls, 566
Woods, 162, *see* Timber ; for pat-
tern making, 180 ; used by
engineers, 180
Wrought iron, analysis of, 56 ;
brands of, 43 ; carbon in, 52 ;
defects in, 52 ; fibre of, 43 ;
properties of, 52 ; manufacture
of, at Low Moor, 35 ; Staffor-
shire, 43 ; tests for, 55
YELLOW pine, 176, 180, 181
York stone, 189, 191
ZINC, alloys of, 148, 156 ; pro-
perties and uses of, 140 ; smelt-
ing of, 140 ; -white, 140

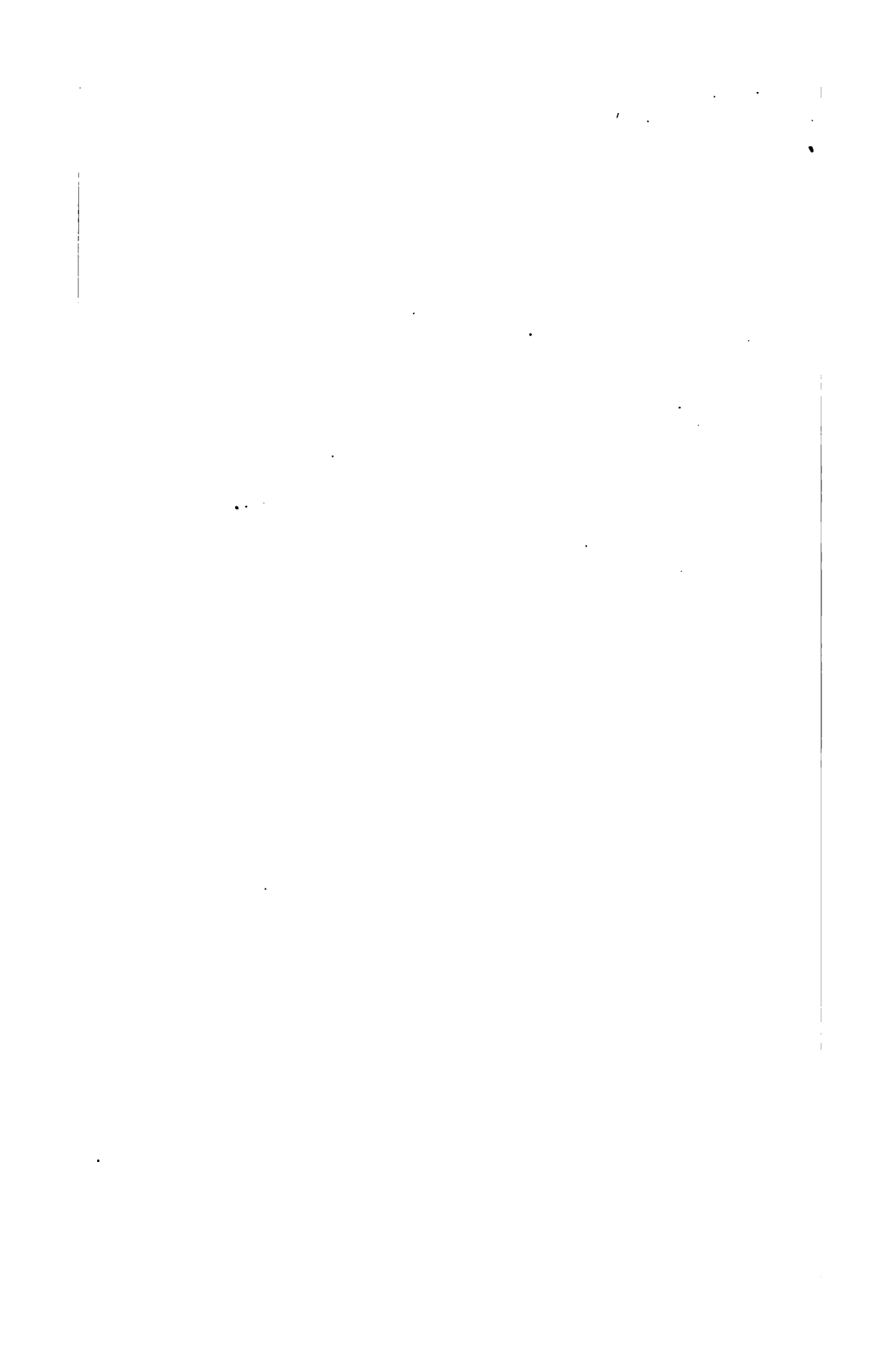

D. VAN NOSTRAND COMPANY

25 PARK PLACE

NEW YORK

SHORT-TITLE CATALOG

OF

Publications and Importations

OF

**SCIENTIFIC AND ENGINEERING
BOOKS**



This list includes all the books published by the

M. C. CLARK PUBLISHING CO.,

Chicago, Ill.,

and the technical publications of the following English publishers:

SCOTT, GREENWOOD & CO. JAMES MUNRO & CO., Ltd.

CONSTABLE & COMPANY, Ltd. TECHNICAL PUBLISHING CO.

ELECTRICIAN PRINTING & PUBLISHING CO.

for whom D. Van Nostrand Company are American agents.

SEPTEMBER, 1915

SHORT-TITLE CATALOG
OF THE
Publications and Importations
OF
D. VAN NOSTRAND COMPANY
25 PARK PLACE, N. Y.

The books published by the
MYRON C. CLARK PUBLISHING CO., Chicago, Ill.
are included in this catalog.

Prices marked with an asterisk () are NET.*
All bindings are in cloth unless otherwise noted.

Abbott, A. V. The Electrical Transmission of Energy.....	8vo,	*\$5 00
— A Treatise on Fuel. (Science Series No. 9.)..	16mo,	0 50
— Testing Machines. (Science Series No. 74.).....	16mo,	0 50
Adam, P. Practical Bookbinding. Trans. by T. E. Maw.....	12mo,	*2 50
Adams, H. Theory and Practice in Designing.....	8vo,	*2 50
Adams, H. C. Sewage of Sea Coast Towns.....	8vo,	*2 00
Adams, J. W. Sewers and Drains for Populous Districts.....	8vo,	2 50
Addyman, F. T. Practical X-Ray Work.....	8vo,	*4 00
Adler, A. A. Theory of Engineering Drawing.....	8vo,	*2 00
— Principles of Parallel Projecting-line Drawing.....	8vo,	*1 00
Aikman, C. M. Manures and the Principles of Manuring.....	8vo,	2 50
Aitken, W. Manual of the Telephone.....	8vo,	*8 00
d'Albe, E. E. F., Contemporary Chemistry.....	12mo,	*1 25
Alexander, J. H. Elementary Electrical Engineering.....	12mo,	2 00
Allan, W. Strength of Beams Under Transverse Loads. (Science Series No. 19.).....	16mo,	0 50
— Theory of Arches. (Science Series No. 11.).....	16mo,	
Allen, H. Modern Power Gas Producer Practice and Applications. 12mo,		*2 50
— Gas and Oil Engines.....	8vo,	*4 50
Anderson, F. A. Boiler Feed Water.....	8vo,	*2 50
Anderson, Capt. G. L. Handbook for the Use of Electricians.....	8vo,	3 00
Anderson, J. W. Prospector's Handbook.....	12mo,	1 50
Andés, L. Vegetable Fats and Oils.....	8vo,	*4 00
— Animal Fats and Oils. Trans. by C. Salter.....	8vo,	*4 00
— Drying Oils, Boiled Oil, and Solid and Liquid Driers.....	8vo,	*5 00
— Iron Corrosion, Anti-fouling and Anti-corrosive Paints. Trans. by C. Salter.....	8vo,	*4 00
Andés, L. Oil Colors, and Printers' Ink. Trans. by A. Morris and H. Robson.....	8vo,	*2 50

Andés, L. Treatment of Paper for Special Purposes. Trans. by C. Salter.	12mo,	*2 50
Andrews, E. S. Reinforced Concrete Construction.....	12mo,	*1 25
— Theory and Design of Structures.....	8vo,	*3 50
— Further Problems in the Theory and Design of Structures....	8vo,	*2 50
Andrews, E. S., and Heywood, H. B. The Calculus for Engineers.	12mo,	*1 25
Annual Reports on the Progress of Chemistry. Twelve Volumes now ready. Vol. I., 1904, Vol. XII., 1914.....	8vo, each,	*2 00
Argand, M. Imaginary Quantities. Translated from the French by A. S. Hardy. (Science Series No. 52.).....	16mo,	0 50
Armstrong, R., and Idell, F. E. Chimneys for Furnaces and Steam Boilers. (Science Series No. 1.).....	16mo,	0 50
Arnold, E. Armature Windings of Direct-Current Dynamos. Trans. by F. B. DeGress.....	8vo,	*2 00
Asch, W., and Asch, D. The Silicates in Chemistry and Commerce.	8vo,	*6 00
Ashe, S. W., and Keiley, J. D. Electric Railways. Theoretically and Practically Treated. Vol. I. Rolling Stock.....	12mo,	*2 50
Ashe, S. W. Electric Railways. Vol. II. Engineering Preliminaries and Direct Current Sub-Stations.....	12mo,	*2 50
— Electricity: Experimentally and Practically Applied.....	12mo,	*2 00
Ashley, R. H. Chemical Calculations.....	12mo,	*2 00
Atkins, W. Common Battery Telephony Simplified.....	12mo,	*1 25
Atkinson, A. A. Electrical and Magnetic Calculations.....	8vo,	*1 50
Atkinson, J. J. Friction of Air in Mines. (Science Series No. 14.).....	16mo,	0 50
Atkinson, J. J., and Williams, Jr., E. H. Gases Met with in Coal Mines. (Science Series No. 13.).....	16mo,	0 55
Atkinson, P. The Elements of Electric Lighting.....	12mo,	1 00
— The Elements of Dynamic Electricity and Magnetism.....	12mo,	2 00
— Power Transmitted by Electricity.....	12mo,	2 00
Auchincloss, W. S. Link and Valve Motions Simplified.....	8vo,	*1 50
Austin, E. Single Phase Electric Railways.....	4to,	*5 00
Ayrton, H. The Electric Arc.....	8vo,	*5 00
Bacon, F. W. Treatise on the Richards Steam-Engine Indicator ..	12mo,	1 00
Bailes, G. M. Modern Mining Practice. Five Volumes	8vo, each,	3 50
Bailey, R. D. The Brewers' Analyst.....	8vo,	*5 00
Baker, A. L. Quaternions.....	8vo,	*1 25
— Thick-Lens Optics.....	12mo,	*1 50
Baker, Benj. Pressure of Earthwork. (Science Series No. 56.).....	16mo,	0 50
Baker, I. O. Levelling. (Science Series No. 91.).....	16mo,	0 50
Baker, M. N. Potable Water. (Science Series No. 61.).....	16mo,	0 50
— Sewerage and Sewage Purification. (Science Series No. 18.).....	16mo,	0 50
Baker, T. T. Telegraphic Transmission of Photographs.....	12mo,	*1 25
Bale, G. R. Modern Iron Foundry Practice. Two Volumes. 12mo.		
Vol. I. Foundry Equipment, Materials Used.....		*2 50
Vol. II. Machine Moulding and Moulding Machines.....		*1 50
Ball, J. W. Concrete Structures in Railways.....	8vo,	*2 50
Ball, R. S. Popular Guide to the Heavens.....	8vo,	*4 50
— Natural Sources of Power. (Westminster Series.).....	8vo,	*2 00
Bal, W. V. Law Affecting Engineers.....	8vo,	*3 50

4 D. VAN NOSTRAND CO.'S SHORT TITLE CATALOG

Bankson, Lloyd. Slide Valve Diagrams. (Science Series No. 108.)	16mo,	0 50
Barba, J. Use of Steel for Constructive Purposes.....	12mo,	1 00
Barham, G. B. Development of the Incandescent Electric Lamp....	8vo,	*2 00
Barker, A. F. Textiles and Their Manufacture. (Westminster Series.)	8vo,	2 00
Barker, A. F., and Midgley, E. Analysis of Textile Fabrics....	8vo,	3 00
Barker, A. H. Graphic Methods of Engine Design.....	12mo,	*1 50
— Heating and Ventilation.....	4to,	*8 00
Barnard, J. H. The Naval Militiaman's Guide.....	16mo, leather	1 00
Barnard, Major J. G. Rotary Motion. (Science Series No. 90.)....	16mo,	0 50
Barrus, G. H. Boiler Tests.....	8vo,	*3 00
— Engine Tests.....	8vo,	*4 00
The above two purchased together.....		*6 00
Barwise, S. The Purification of Sewage.....	12mo,	3 50
Baterden, J. R. Timber. (Westminster Series.).....	8vo,	*2 00
Bates, E. L., and Charlesworth, F. Practical Mathematics.....	12mo,	
Part I. Preliminary and Elementary Course.....		*1 50
Part II. Advanced Course.....		*1 50
— Practical Mathematics.....	12mo,	*1 50
— Practical Geometry and Graphics.....	12mo,	*2 00
Batey, J. The Science of Works Management.....	12mo,	*1 25
Beadle, C. Chapters on Papermaking. Five Volumes.....	12mo, each,	*2 00
Beaumont, R. Color in Woven Design.....	8vo,	*6 00
— Finishing of Textile Fabrics.....	8vo,	*4 00
Beaumont, W. W. The Steam-Engine Indicator.....	8vo,	2 50
Bechhold, H. Colloids in Biology and Medicine. Trans. by J. G. Bullowa.....		(In Press.)
Beckwith, A. Pottery.....	8vo, paper,	0 60
Bedell, F., and Pierce, C. A. Direct and Alternating Current Manual.....	8vo,	*2 00
Beech, F. Dyeing of Cotton Fabrics.....	8vo,	*3 00
— Dyeing of Woolen Fabrics.....	8vo,	*3 50
Begtrup, J. The Slide Valve.....	8vo,	*2 00
Beggs, G. E. Stresses in Railway Girders and Bridges.....	(In Press.)	
Bender, C. E. Continuous Bridges. (Science Series No. 26.)....	16mo,	0 50
— Proportions of Pins used in Bridges. (Science Series No. 4.).....	16mo,	0 50
Bengough, G. D. Brass. (Metallurgy Series.).....	(In Press.)	
Bennett, H. G. The Manufacture of Leather.....	8vo,	*4 50
Besnthen, A. A Text - book of Organic Chemistry. Trans. by G. M'Gowan.....	12mo,	*2 50
Berry, W. J. Differential Equations of the First Species. 12mo. (In Preparation.)		
Bersch, J. Manufacture of Mineral and Lake Pigments. Trans. by A. C. Wright.....	8vo,	*5 00
Bertin, L. E. Marine Boilers. Trans. by L. S. Robertson.....	8vo,	5 00
Beveridge, J. Papermaker's Pocket Book.....	12mo,	*4 00
Binnie, Sir A. Rainfall Reservoirs and Water Supply.....	8vo,	*3 00
Binns, C. F. Manual of Practical Potting.....	8vo,	*7 50
— The Potter's Craft.....	12mo,	*2 00
Birchmore, W. H. Interpretation of Gas Analysis.....	12mo,	*1 25
Blaine, R. G. The Calculus and Its Applications.....	12mo,	*1 50

Blake, W. H. <i>Brewers' Vade Mecum</i>	8vo,	*4 00
Blasdale, W. C. <i>Quantitative Chemical Analysis. (Van Nostrand's Textbooks.)</i>	12mo,	*2 50
Bligh, W. G. <i>The Practical Design of Irrigation Works</i>	8vo,	*6 00
Bloch, L. <i>Science of Illumination. Trans. by W. C. Clinton</i>	8vo,	*2 50
Blok, A. <i>Illumination and Artificial Lighting</i>	12mo,	1 25
Blücher, H. <i>Modern Industrial Chemistry. Trans. by J. P. Millington.</i>	8vo,	*7 50
Blyth, A. W. <i>Foods: Their Composition and Analysis</i>	8vo,	7 50
— <i>Poisons: Their Effects and Detection</i>	8vo,	7 50
Böckmann, F. <i>Celluloid</i>	12mo,	*2 50
Bodmer, G. R. <i>Hydraulic Motors and Turbines</i>	12mo,	5 00
Boileau, J. T. <i>Traverse Tables</i>	8vo,	5 00
Bonney, G. E. <i>The Electro-platers' Handbook</i>	12mo,	1 20
Booth, N. <i>Guide to the Ring-spinning Frame</i>	12mo,	*1 25
Booth, W. H. <i>Water Softening and Treatment</i>	8vo,	*2 50
— <i>Superheaters and Superheating and Their Control</i>	8vo,	*1 50
Bottcher, A. <i>Cranes: Their Construction, Mechanical Equipment and Working. Trans. by A. Tolhausen</i>	4to,	*10 00
Bottler, M. <i>Modern Bleaching Agents. Trans. by C. Salter</i>	12mo,	*2 50
Bottone, S. R. <i>Magnetos for Automobilists</i>	12mo,	*1 00
Boulton, S. B. <i>Preservation of Timber. (Science Series No. 82.)</i>	16mo,	0 50
Bourcart, E. <i>Insecticides, Fungicides and Weedkillers</i>	8vo,	*4 50
Bourgougnon, A. <i>Physical Problems. (Science Series No. 113.)</i>	16mo,	0 50
Bourry, E. <i>Treatise on Ceramic Industries. Trans. by A. B. Searle.</i>	8vo,	*5 00
Bowie, A. J., Jr. <i>A Practical Treatise on Hydraulic Mining</i>	8vo,	5 00
Bowles, O. <i>Tables of Common Rocks. (Science Series No. 125.)</i>	16mo,	0 50
Bowser, E. A. <i>Elementary Treatise on Analytic Geometry</i>	12mo,	1 75
— <i>Elementary Treatise on the Differential and Integral Calculus</i>	12mo,	2 25
— <i>Elementary Treatise on Analytic Mechanics</i>	12mo,	3 00
— <i>Elementary Treatise on Hydro-mechanics</i>	12mo,	2 50
— <i>A Treatise on Roofs and Bridges</i>	12mo,	*2 25
Boycott, G. W. M. <i>Compressed Air Work and Diving</i>	8vo,	*4.00
Bragg, E. M. <i>Marine Engine Design</i>	12mo,	*2 00
— <i>Design of Marine Engines and Auxiliaries. (In Press.)</i>		
Brainard, F. R. <i>The Sextant. (Science Series No. 101.)</i>	16mo,	
Brassey's <i>Naval Annual for 1915</i>	8vo,	
Brew, W. <i>Three-Phase Transmission</i>	8vo,	*2 00
Briggs, R., and Wolff, A. R. <i>Steam-Heating. (Science Series No. 67.)</i>	16mo,	0 50
Bright, C. <i>The Life Story of Sir Charles Tilson Bright</i>	8vo,	*4 50
Brislee, T. J. <i>Introduction to the Study of Fuel. (Outlines of Industrial Chemistry.)</i>	8vo,	*3 00
Broadfoot, S. K. <i>Motors, Secondary Batteries. (Installation Manuals Series.)</i>	12mo,	*0 75
Broughton, H. H. <i>Electric Cranes and Hoists</i>		*9 00
Brown, G. <i>Healthy Foundations. (Science Series No. 80.)</i>	16mo,	0 50
Brown, H. <i>Irrigation</i>	8vo,	*5 00
Brown, Wm. N. <i>The Art of Enamelling on Metal</i>	12mo,	*1 00

6 D. VAN NOSTRAND CO.'S SHORT TITLE CATALOG

Brown, Wm. N. Dipping, Burnishing, Lacquering and Bronzing Brass Ware.....	12mo,	*1 00
— Handbook on Japanning and Enamelling.....	12mo,	*1 50
— House Decorating and Painting.....	12mo,	*1 50
— History of Decorative Art.....	12mo,	*1 25
— Workshop Wrinkles.....	8vo,	*1 00
Browne, C. L. Fitting and Erecting of Engines.....	8vo,	*1 50
Browne, R. E. Water Meters. (Science Series No. 81.).....	16mo,	0 50
Bruce, E. M. Pure Food Tests.....	12mo,	*1 25
Bruhns, Dr. New Manual of Logarithms.....	8vo, cloth,	2 00
	half morocco,	2 50
Brunner, R. Manufacture of Lubricants, Shoe Polishes and Leather Dressings. Trans. by C. Salter.....	8vo,	*3 00
Buel, R. H. Safety Valves. (Science Series No. 21.).....	16mo,	0 50
Burley, G. W. Lathes, Their Construction and Operation.....	12mo,	1 25
Burstall, F. W. Energy Diagram for Gas. With Text.....	8vo,	1 50
— Diagram. Sold separately.....		*1 00
Burt, W. A. Key to the Solar Compass.....	16mo, leather,	2 50
Buskett, E. W. Fire Assaying.....	12mo,	*1 25
Butler, H. J. Motor Bodies and Chassis.....	8vo,	*2 50
Byers, H. G., and Knight, H. G. Notes on Qualitative Analysis....	8vo,	*1 50
Cain, W. Brief Course in the Calculus.....	12mo,	*1 75
— Elastic Arches. (Science Series No. 48.).....	16mo,	0 50
— Maximum Stresses. (Science Series No. 38.).....	16mo,	0 50
— Practical Designing Retaining of Walls. (Science Series No. 3.)	16mo,	0 50
— Theory of Steel-concrete Arches and of Vaulted Structures. (Science Series No. 42.).....	16mo,	0 50
— Theory of Voussoir Arches. (Science Series No. 12.).....	16mo,	0 50
— Symbolic Algebra. (Science Series No. 73.).....	16mo,	0 50
Carpenter, F. D. Geographical Surveying. (Science Series No. 37.).....	16mo,	
Carpenter, R. C., and Diederichs, H. Internal Combustion Engines.....	8vo,	*5 00
Carter, E. T. Motive Power and Gearing for Electrical Machinery.....	8vo,	3 50
Carter, H. A. Ramie (Rhea), China Grass.....	12mo,	*2 00
Carter, H. R. Modern Flax, Hemp, and Jute Spinning.....	8vo,	*3 00
— Bleaching, Dyeing and Finishing of Fabrics.....	8vo,	*1 00
Cary, E. R. Solution of Railroad Problems with the Slide Rule.....	16mo,	*1 00
Cathcart, W. L. Machine Design. Part I. Fastenings.....	8vo,	*3 00
Cathcart, W. L., and Chaffee, J. I. Elements of Graphic Statics....	8vo,	*3 00
— Short Course in Graphics.....	12mo,	1 50
Caven, R. M., and Lander, G. D. Systematic Inorganic Chemistry.....	12mo,	*2 00
Chalkley, A. P. Diesel Engines.....	8vo,	*3 00
Chambers' Mathematical Tables.....	8vo,	1 75
Chambers, G. F. Astronomy.....	16mo,	*1 50
Charpentier, P. Timber.....	8vo,	*6 00
Chatley, H. Principles and Designs of Aeroplanes. (Science Series No. 126).....	16mo,	0 50
— How to Use Water Power.....	12mo,	*1 00
— Gyrostatic Balancing.....	8vo,	*1 00

Child, C. D. Electric Arc.....	8vo,	*2 00
Child, C. T. The How and Why of Electricity.....	12mo,	1 00
Christian, M. Disinfection and Disinfectants. Trans. by Chas. Salter.....	12mo,	2 00
Christie, W. W. Boiler-waters, Scale, Corrosion, Foaming.....	8vo,	*3 00
— Chimney Design and Theory.....	8vo,	*3 00
— Furnace Draft. (Science Series No. 123.).....	16mo,	0 50
— Water: Its Purification and Use in the Industries.....	8vo,	*2 00
Church's Laboratory Guide. Rewritten by Edward Kinch.....	8vo,	*2 50
Clapperton, G. Practical Papermaking.....	8vo,	2 50
Clark, A. G. Motor Car Engineering.		
Vol. I. Construction.....		*3 00
Vol. II. Design.....	(In Press.)	
Clark, C. H. Marine Gas Engines.....	12mo,	*1 50
Clark, J. M. New System of Laying Out Railway Turnouts.....	12mo,	1 00
Clarke, J. W., and Scott, W. Plumbing Practice.		
Vol. I. Lead Working and Plumbers' Materials.....	8vo,	*4 00
Vol. II. Sanitary Plumbing and Fittings.....	(In Press.)	
Vol. III. Practical Lead Working on Roofs.....	(In Press.)	
Clausen-Thue, W. A B C Telegraphic Code. Fourth Edition.....	12mo,	*5 00
Fifth Edition.....	8vo,	*7 00
— The A 1 Telegraphic Code.....	8vo,	*7 50
Clerk, D., and Idell, F. E. Theory of the Gas Engine. (Science Series No. 62.).....	16mo,	0 50
Clevenger, S. R. Treatise on the Method of Government Surveying.	16mo, morocco,	2 50
Clouth, F. Rubber, Gutta-Percha, and Balata.....	8vo,	*5 00
Cochran, J. Concrete and Reinforced Concrete Specifications.....	8vo,	*2 50
— Inspection of Concrete Construction.....	8vo,	*4 00
— Treatise on Cement Specifications.....	8vo,	*1 00
Coffin, J. H. C. Navigation and Nautical Astronomy.....	12mo,	*3 50
Colburn, Z., and Thurston, R. H. Steam Boiler Explosions. (Science Series No. 2.).....	16mo,	0 50
Cole, R. S. Treatise on Photographic Optics.....	12mo,	1 50
Coles-Finch, W. Water, Its Origin and Use.....	8vo,	*5 00
Collins, J. E. Useful Alloys and Memoranda for Goldsmiths, Jewelers.	16mo,	0 50
Collis, A. G. High and Low Tension Switch-Gear Design.....	8vo,	*3 50
— Switchgear. (Installation Manuals Series.).....	12mo,	*0 50
Comstock, D. F., and Toland, L. T. Modern Theory of the Constitution of Matter.....	(In Press.)	
Constantine, E. Marine Engineers, Their Qualifications and Duties. 8vo,		*2 00
Coombs, H. A. Gear Teeth. (Science Series No. 120.).....	16mo,	0 50
Cooper, W. R. Primary Batteries.....	8vo,	*4 00
Copperthwaite, W. C. Tunnel Shields.....	4to,	*9 00
Corey, H. T. Water Supply Engineering.....	8vo (In Press.)	
Corfield, W. H. Dwelling Houses. (Science Series No. 50.).....	16mo,	0 50
— Water and Water-Supply. (Science Series No. 17.).....	16mo,	0 50
Cornwall, H. B. Manual of Blow-pipe Analysis.....	8vo,	*2 50

8 D. VAN NOSTRAND CO.'S SHORT TITLE CATALOG

Courtney, C. F. Masonry Dams	8vo,	3 50
Cowell, W. B. Pure Air, Ozone, and Water	12mo,	*2 00
Craig, J. W., and Woodward, W. P. Questions and Answers About Electrical Apparatus	12mo, leather,	1 50
Craig, T. Motion of a Solid in a Fuel. (Science Series No. 49.)	16mo,	0 50
— Wave and Vortex Motion. (Science Series No. 43.)	16mo,	0 50
Cramp, W. Continuous Current Machine Design	8vo,	*2 50
Creedy, F. Single Phase Commutator Motors	8vo,	*2 00
Crocker, F. B. Electric Lighting. Two Volumes. 8vo.		
Vol. I. The Generating Plant		3 00
Vol. II. Distributing Systems and Lamps		
Crocker, F. B., and Arendt, M. Electric Motors	8vo,	*2 50
Crocker, F. B., and Wheeler, S. S. The Management of Electrical Machinery	12mo,	*1 00
Cross, C. F., Bevan, E. J., and Sindall, R. W. Wood Pulp and Its Applications. (Westminster Series.)	8vo,	*2 00
Crosskey, L. R. Elementary Perspective	8vo,	1 00
Crosskey, L. R., and Thaw, J. Advanced Perspective	8vo,	1 50
Culley, J. L. Theory of Arches. (Science Series No. 87.)	16mo,	0 50
Dadourian, H. M. Analytical Mechanics	12mo,	*3 00
Dana, R. T. Handbook of Construction plant	12mo, leather,	*5 00
Danby, A. Natural Rock Asphalts and Bitumens	8vo,	*2 50
Davenport, C. The Book. (Westminster Series.)	8vo,	*2 00
Davey, N. The Gas Turbine	8vo,	*4 00
Davies, F. H. Electric Power and Traction	8vo,	*2 00
— Foundations and Machinery Fixing. (Installation Manual Series.)	6mo,	*1 00
Dawson, P. Electric Traction on Railways	8vo,	*9 00
Deerr, N. Sugar Cane	8vo,	*7 00
Deite, C. Manual of Soapmaking. Trans. by S. T. King	4to,	*5 00
De la Coux, H. The Industrial Uses of Water. Trans. by A. Morris.	8vo,	*4 50
Del Mar, W. A. Electric Power Conductors	8vo,	*2 00
Denny, G. A. Deep-level Mines of the Rand	4to,	*10 00
— Diamond Drilling for Gold		*5 00
De Roos, J. D. C. Linkages. (Science Series No. 47.)	16mo,	0 50
Derr, W. L. Block Signal Operation	Oblong 12mo,	*1 50
— Maintenance-of-Way Engineering	(In Preparation.)	
Desaint, A. Three Hundred Shades and How to Mix Them	8vo,	*8 00
De Varona, A. Sewer Gases. (Science Series No. 55.)	16mo,	0 50
Devey, R. G. Mill and Factory Wiring. (Installation Manuals Series.)	12mo,	*1 00
Dibdin, W. J. Purification of Sewage and Water	8vo,	6 50
Dichmann, Carl. Basic Open-Hearth Steel Process	12mo,	*3 50
Dieterich, K. Analysis of Resins, Balsams, and Gum Resins	8vo,	*3 00
Dinger, Lieut. H. C. Care and Operation of Naval Machinery	12mo,	*2 00
Dixon, D. B. Machinist's and Steam Engineer's Practical Calculator.	16mo, morocco,	1 25
Doble, W. A. Power Plant Construction on the Pacific Coast (In Press.)		

Dodge, G. F. Diagrams for Designing Reinforced Concrete Structures,	folio,	*4 00
Dommett, W. E. Motor Car Mechanism.....	12mo,	*1 25
Dorr, B. F. The Surveyor's Guide and Pocket Table-book.	16mo, morocco,	2 00
Down, P. B. Handy Copper Wire Table.....	16mo,	*1 00
Draper, C. H. Elementary Text-book of Light, Heat and Sound . . .	12mo,	1 00
—Heat and the Principles of Thermo-dynamics.....	12mo,	*2 00
Dron, R. W. Mining Formulas.....	12mo,	1 00
Dubbel, H. High Power Gas Engines.....	8vo,	*5 00
Duckwall, E. W. Canning and Preserving of Food Products	8vo,	*5 00
Dumesny, P., and Noyer, J. Wood Products, Distillates, and Extracts.	8vo,	*4 50
Duncan, W. G., and Penman, D. The Electrical Equipment of Collieries.	8vo,	*4 00
Dunstan, A. E., and Thole, F. B. T. Textbook of Practical Chemistry.	12mo,	*1 40
Duthie, A. L. Decorative Glass Processes. (Westminster Series.)	8vo,	*2 00
Dwight, H. B. Transmission Line Formulas.....	8vo,	*2 00
Dyson, S. S. Practical Testing of Raw Materials.....	8vo,	*5 00
Dyson, S. S., and Clarkson, S. S. Chemical Works.....	8vo,	*7 50
Eccles, R. G., and Duckwall, E. W. Food Preservatives....	8vo, paper,	0 50
Ecclea, W. H. Wireless Telegraphy and Telephony.....	(In Press.)	
Eck, J. Light, Radiation and Illumination. Trans. by Paul Hogner,	8vo,	*2 50
Eddy, H. T. Maximum Stresses under Concentrated Loads.....	8vo,	1 50
Edelman, P. Inventions and Patents.....	12mo. (In Press.)	
Edgcumbe, K. Industrial Electrical Measuring Instruments....	8vo,	
Edler, R. Switches and Switchgear. Trans. by Ph. Laubach..	8vo,	*4 00
Eissler, M. The Metallurgy of Gold.....	8vo,	7 50
— The Metallurgy of Silver.....	8vo,	4 00
— The Metallurgy of Argentiferous Lead.....	8vo,	5 00
— A Handbook on Modern Explosives.....	8vo,	5 00
Ekin, T. C. Water Pipe and Sewage Discharge Diagrams.....	folio,	*3 00
Electric Light Carbons, Manufacture of.....	8vo,	1 00
Eliot, C. W., and Storer, F. H. Compendious Manual of Qualitative		
Chemical Analysis.....	12mo,	*1 25
Ellis, C. Hydrogenation of Oils.....	8vo,	*4 00
Ellis, G. Modern Technical Drawing.....	8vo,	*2 00
Ennis, Wm. D. Linseed Oil and Other Seed Oils.....	8vo,	*4 00
— Applied Thermodynamics.....	8vo,	*4 50
— Flying Machines To-day.....	12mo,	*4 50
— Vapors for Heat Engines.....	12mo,	*1 00
Erfurt, J. Dyeing of Paper Pulp. Trans. by J. Hubner.....		
Ermen, W. F. A. Materials Used in Sizing.....	8vo,	*2 00
Erwin, M. The Universe and the Atom.....	(In Press.)	
Evans, C. A. Macadamized Roads.....	(In Press.)	

Ewing, A. J. Magnetic Induction in Iron.....	8vo,	*4 00
Fairie, J. Notes on Lead Ores.....	12mo,	*1 00
— Notes on Pottery Clays.....	12mo,	*1 50
Fairley, W., and Andre, Geo. J. Ventilation of Coal Mines. (Science Series No. 58.).....	16mo,	0 50
Fairweather, W. C. Foreign and Colonial Patent Laws.....	8vo,	*3 00
Falk, M. S. Cement Mortars and Concretes.....	8vo,	*2 50
Fanning, J. T. Hydraulic and Water-supply Engineering.....	8vo,	*5 00
Fay, I. W. The Coal-tar Colors.....	8vo,	*4 00
Fernbach, R. L. Glue and Gelatine.....	8vo,	*3 00
— Chemical Aspects of Silk Manufacture.....	12mo,	*1 00
Fischer, E. The Preparation of Organic Compounds. Trans. by R. V. Stanford.....	12mo,	*1 25
Fish, J. C. L. Lettering of Working Drawings.....	Oblong 8vo,	1 00
— Mathematics of the Paper Location of a Railroad. paper, 12mo,		*0 25
Fisher, H. K. C., and Darby, W. C. Submarine Cable Testing....	8vo,	*3 50
Fleischmann, W. The Book of the Dairy. Trans. by C. M. Aikman.	8vo,	4 00
Fleming, J. A. The Alternate-current Transformer. Two Volumes. 8vo.		
Vol. I. The Induction of Electric Currents.....		*5 00
Vol. II. The Utilization of Induced Currents.....		*5 00
Fleming, J. A. Propagation of Electric Currents.....	8vo,	*3 00
— A Handbook for the Electrical Laboratory and Testing Room. Two Volumes.....	8vo, each,	*5 00
Fleury, P. Preparation and Uses of White Zinc Paints.....	8vo,	*2 50
Flynn, P. J. Flow of Water. (Science Series No. 84.).....	12mo,	0 50
— Hydraulic Tables. (Science Series No. 66.).....	16mo,	0 50
Forgie, J. Shield Tunneling.....	8vo. (<i>In Press.</i>)	
Foster, H. A. Electrical Engineers' Pocket-book. (<i>Seventh Edition.</i>)	12mo, leather,	5 00
— Engineering Valuation of Public Utilities and Factories.....	8vo,	*3 00
— Handbook of Electrical Cost Data.....	8vo (<i>In Press.</i>)	
Foster, Gen. J. G. Submarine Blasting in Boston (Mass.) Harbor	4to,	3 50
Fowle, F. F. Overhead Transmission Line Crossings.....	12mo,	*1 50
— The Solution of Alternating Current Problems.....	8vo (<i>In Press.</i>)	
Fox, W. G. Transition Curves. (Science Series No. 110.).....	16mo,	0 50
Fox, W., and Thomas, C. W. Practical Course in Mechanical Drawing.....	12mo,	1 25
Foye, J. C. Chemical Problems. (Science Series No. 69.).....	16mo,	0 50
— Handbook of Mineralogy. (Science Series No. 86.).....	16mo,	0 50
Francis, J. B. Lowell Hydraulic Experiments.....	4to,	15 00
Franzen, H. Exercises in Gas Analysis.....	12mo,	*1 00
French, J. W. Machine Tools, 2 vols.....	4to,	*15 00
Freudemacher, P. W. Electrical Mining Installations. (<i>Installation Manuals Series.</i>).....	12mo,	*1 00
Frith, J. Alternating Current Design.....	8vo,	*2 00
Fritsch, J. Manufacture of Chemical Manures. Trans. by D. Grant.	8vo,	*4 00

D. VAN NOSTRAND CO.'S SHORT TITLE CATALOG 11

Frye, A. I. Civil Engineers' Pocket-book.....	12mo, leather,	*5 00
Fuller, G. W. Investigations into the Purification of the Ohio River.	4to,	*10 00
Furnell, J. Paints, Colors, Oils, and Varnishes.....	8vo.	*1 00
Gairdner, J. W. I. Earthwork.....	8vo (<i>In Press.</i>)	
Gant, L. W. Elements of Electric Traction.....	8vo,	*2 50
Garcia, A. J. R. V. Spanish-English Railway Terms.....	8vo,	*4 50
Garforth, W. E. Rules for Recovering Coal Mines after Explosions and Fires.....	12mo, leather,	1 50
Garrard, C. C. Electric Switch and Controlling Gear....(<i>In Press.</i>)		
Gaudard, J. Foundations. (Science Series No. 34.).....	16mo,	0 50
Gear, H. B., and Williams, P. F. Electric Central Station Distribution Systems.....	8vo,	*3 00
Geerligs, H. C. P. Cane Sugar and Its Manufacture.....	8vo,	*5 00
Geikie, J. Structural and Field Geology.....	8vo,	*4 00
— Mountains. Their Growth, Origin and Decay.....	8vo,	*4 00
— The Antiquity of Man in Europe.....	8vo,	*3 00
Georgi, F., and Schubert, A. Sheet Metal Working. Trans. by C. Salter.....	8vo,	3 00
Gerber, N. Analysis of Milk, Condensed Milk, and Infants' Milk-Food. 8vo,		1 25
Gerhard, W. P. Sanitation, Watersupply and Sewage Disposal of Country Houses.....	12mo,	*2 00
— Gas Lighting (Science Series No. 111.).....	16mo,	0 50
— Household Wastes. (Science Series No. 97.).....	16mo,	0 50
— House Drainage. (Science Series No. 63.).....	16mo,	0 50
Gerhard, W. P. Sanitary Drainage of Buildings. (Science Series No. 93.)	16mo,	0 50
Gerhardi, C. W. H. Electricity Meters.....	8vo,	*4 00
Geschwind, L. Manufacture of Alum and Sulphates. Trans. by C. Salter.....	8vo,	*5 00
Gibbs, W. E. Lighting by Acetylene.....	12mo,	*1 50
Gibson, A. H. Hydraulics and Its Application.....	8vo,	*5 00
— Water Hammer in Hydraulic Pipe Lines.....	12mo,	*2 00
Gibson, A. H., and Ritchie, E. G. Circular Arc Bow Girder.....	4to,	*3 50
Gilbreth, F. B. Motion Study.....	12mo,	*2 00
— Bricklaying System.....	8vo,	*3 00
— Field System.....	12mo, leather,	*3 00
— Primer of Scientific Management.....	12mo,	*1 00
Gillette, H. P. Handbook of Cost Data.....	12mo, leather,	*5 00
— Rock Excavation Methods and Cost.....	12mo,	*3 00
— and Dana, R. T. Cost Keeping and Management Engineering. 8vo,		*3 50
— and Hill, C. S. Concrete Construction, Methods and Cost... 8vo,		*5 00
Gillmore, Gen. Q. A. Limes, Hydraulic Cements and Mortars.....	8vo,	4 00
— Roads, Streets, and Pavements.....	12mo,	2 00
Godfrey, E. Tables for Structural Engineers.....	16mo, leather,	*2 50
Golding, H. A. The Theta-Phi Diagram.....	12mo,	*1 25
Goldschmidt, R. Alternating Current Commutator Motor.....	8vo,	*3 00
Goodchild, W. Precious Stones. (Westminster Series.).....	8vo,	*2 00

12 D. VAN NOSTRAND CO.'S SHORT TITLE CATALOG

Goodeve, T. M. Textbook on the Steam-engine.....	12mo,	2 00
Gors, C. Electrolytic Separation of Metals.....	8vo,	*3 50
Gould, E. S. Arithmetic of the Steam-engine.....	12mo,	1 00
— Calculus. (Science Series No. 112.).....	16mo,	0 50
— High Masonry Dams. (Science Series No. 22.).....	16mo,	0 50
— Practical Hydrostatics and Hydrostatic Formulas. (Science Series No. 117.).....	16mo,	0 50
Gratacap, L. P. A Popular Guide to Minerals.....	8vo,	*3 00
Gray, J. Electrical Influence Machines.....	12mo,	2 00
— Marine Boiler Design.....	12mo,	*1 25
Greenhill, G. Dynamics of Mechanical Flight.....	8vo,	*2 50
Greenwood, E. Classified Guide to Technical and Commercial Books.....	8vo,	*3 00
Gregorius, R. Mineral Waxes. Trans. by C. Salter.....	12mo,	*3 00
Griffiths, A. B. A Treatise on Manures.....	12mo,	3 00
— Dental Metallurgy.....	8vo,	*3 50
Gross, E. Hops.....	8vo,	*4 50
Grossman, J. Ammonia and Its Compounds.....	12mo,	*1 25
Groth, L. A. Welding and Cutting Metals by Gases or Electricity. (Westminster Series).....	8vo,	*2 00
Grover, F. Modern Gas and Oil Engines.....	8vo,	*2 00
Gruner, A. Power-loom Weaving.....	8vo,	*3 00
Guldner, Hugo. Internal Combustion Engines. Trans. by H. Diederichs.	4to,	*10 00
Gunther, C. O. Integration.....		
Gurden, R. L. Traverse Tables.....	folio, half morocco,	*7 50
Guy, A. E. Experiments on the Flexure of Beams.....	8vo,	*1 25
Haenig, A. Emery and Emery Industry.....	8vo,	*2 50
Hainbach, R. Pottery Decoration. Trans. by C. Salter.....	12mo,	*3 00
Hale, W. J. Calculations of General Chemistry.....	12mo,	*1 00
Hall, C. H. Chemistry of Paints and Paint Vehicles.....	12mo,	*2 00
Hall, G. L. Elementary Theory of Alternate Current Working.....	8vo,	*1 50
Hall, R. H. Governors and Governing Mechanism.....	12mo,	*2 00
Hall, W. S. Elements of the Differential and Integral Calculus.....	8vo,	*2 25
— Descriptive Geometry.....	8vo volume and a 4to atlas,	*3 50
Haller, G. F., and Cunningham, E. T. The Tesla Coil.....	12mo,	*1 25
Halsey, F. A. Slide Valve Gears.....	12mo,	1 50
— The Use of the Slide Rule. (Science Series No. 114.).....	16mo,	0 50
— Worm and Spiral Gearing. (Science Series No. 116.).....	16mo,	0 50
Hamilton, W. G. Useful Information for Railway Men.....	16mo,	1 00
Hammer, W. J. Radium and Other Radio-active Substances.....	8vo,	*1 00
Hancock, H. Textbook of Mechanics and Hydrostatics.....	8vo,	1 50
Hancock, W. C. Refractory Materials. (Metallurgy Series.) (In Press.)		
Hardy, E. Elementary Principles of Graphic Statics.....	12mo,	*1 50
Haring, H. Engineering Law.		
Vol. I. Law of Contract.....	8vo,	*4 00
Harris, S. M. Practical Topographical Surveying..... (In Press.)		
Harrison, W. B. The Mechanics' Tool-book.....	12mo,	1 50
Hart, J. W. External Plumbing Work.....	8vo,	*3 00
— Hints to Plumbers on Joint Wiping.....	8vo,	*3 00

— Principles of Hot Water Supply.....	8vo,	*3 00
— Sanitary Plumbing and Drainage.....	8vo,	*3 00
Haskins, C. H. The Galvanometer and Its Uses.....	16mo,	1 50
Hatt, J. A. H. The Colorist.....	square 12mo,	*1 50
Hausbrand, E. Drying by Means of Air and Steam. Trans. by A. C. Wright.....	12mo,	*2 00
— Evaporating, Condensing and Cooling Apparatus. Trans. by A. C. Wright.....	8vo,	*5 00
Hausmann, E. Telegraph Engineering.....	8vo,	*3 00
Hausner, A. Manufacture of Preserved Foods and Sweetmeats. Trans. by A. Morris and H. Robson.....	8vo,	*3 00
Hawkesworth, J. Graphical Handbook for Reinforced Concrete Design.	4to,	*2 50
Hay, A. Alternating Currents.....	8vo,	*2 50
— Electrical Distributing Networks and Distributing Lines.....	8vo,	*3 50
— Continuous Current Engineering.....	8vo,	*2 50
Hayes, H. V. Public Utilities, Their Cost New and Depreciation... 8vo,		*2 00
— Public Utilities, Their Fair Present Value and Return.....	8vo,	*2 00
Heather, H. J. S. Electrical Engineering.....	8vo,	*3 50
Heaviside, O. Electromagnetic Theory. Vols. I and II... 8vo, each,		*5 00
Vol. III.....	8vo,	*7 50
Heck, R. C. H. The Steam Engine and Turbine.....	8vo,	*3 50
— Steam-Engine and Other Steam Motors. Two Volumes.		
Vol. I. Thermodynamics and the Mechanics.....	8vo,	*3 50
Vol. II. Form, Construction, and Working.....	8vo,	*5 00
— Notes on Elementary Kinematics.....	8vo, boards,	*1 00
— Graphics of Machine Forces.....	8vo, boards,	*1 00
Heermann, P. Dyers' Materials. Trans. by A. C. Wright.....	12mo,	*2 50
Heidenreich, E. L. Engineers' Pocketbook of Reinforced Concrete,	16mo, leather,	*3 00
Hellot, Macquer and D'Apligny. Art of Dyeing Wool, Silk and Cotton. 8vo,		*2 00
Henrici, O. Skeleton Structures.....	8vo,	1 50
Hering, D. W. Essentials of Physics for College Students.....	8vo,	*1 75
Hering-Shaw, A. Domestic Sanitation and Plumbing. Two Vols... 8vo,		*5 00
Hering-Shaw, A. Elementary Science.....	8vo,	*2 00
Herrmann, G. The Graphical Statics of Mechanism. Trans. by A. P. Smith.....	12mo,	2 00
Herzfeld, J. Testing of Yarns and Textile Fabrics.....	8vo,	*3 50
Hildebrandt, A. Airships, Past and Present.....	8vo,	*3 50
Hildenbrandt, B. W. Cable-Making. (Science Series No. 32.)... 16mo,		0 50
Hilditch, T. P. A Concise History of Chemistry.....	12mo,	*1 25
Hill, C. S. Concrete Inspection.....	16mo,	*1 00
Hill, J. W. The Purification of Public Water Supplies. New Edition. (In Press.)		
— Interpretation of Water Analysis..... (In Press.)		
Hill, M. J. M. The Theory of Proportion.....	8vo,	*2 50
Hiroi, I. Plate Girder Construction. (Science Series No. 95.)... 16mo,		0 50
— Statically-Indeterminate Stresses.....	12mo,	*2 00
Hirshfeld, C. F. Engineering Thermodynamics. (Science Series No. 45.)	16mo,	0 50

Hobart, H. M. Heavy Electrical Engineering.....	8vo,	*4 50
— Design of Static Transformers.....	12mo,	*2 00
— Electricity.....	8vo,	*2 00
— Electric Trains.....	8vo,	*2 50
Hobart, H. M. Electric Propulsion of Ships.....	8vo,	*2 00
Hobart, J. F. Hard Soldering, Soft Soldering and Brazing.....	12mo,	*1 00
Hobbs, W. R. P. The Arithmetic of Electrical Measurements....	12mo,	0 50
Hoff, J. N. Paint and Varnish Facts and Formulas.....	12mo,	*1 50
Hole, W. The Distribution of Gas.....	8vo,	*7 50
Holley, A. L. Railway Practice.....	folio,	6 00
Holmes, A. B. The Electric Light Popularly Explained... 12mo, paper,		0 50
Hopkins, N. M. Experimental Electrochemistry.....	8vo,	
— Model Engines and Small Boats.....	12mo,	1 25
Hopkinson, J., Shoolbred, J. N., and Day, R. E. Dynamic Electricity. (Science Series No. 71.).....	16mo,	0 50
Horner, J. Practical Ironfounding.....	8vo,	*2 00
— Gear Cutting, in Theory and Practice.....	8vo,	*3 00
Houghton, C. E. The Elements of Mechanics of Materials.....	12mo,	*2 00
Houllévigüe, L. The Evolution of the Sciences.....	8vo,	*2 00
Houstoun, R. A. Studies in Light Production.....	12mo,	2 00
Hovenden, F. Practical Mathematics for Young Engineers.....	12mo,	*1 00
Howe, G. Mathematics for the Practical Man.....	12mo,	*1 25
Howorth, J. Repairing and Riveting Glass, China and Earthenware. 8vo, paper,		*0 50
Hubbard, E. The Utilization of Wood-waste.....	8vo,	*2 50
Hübner, J. Bleaching and Dyeing of Vegetable and Fibrous Materials. (Outlines of Industrial Chemistry.).....	8vo,	*5 00
Hudson, O. F. Iron and Steel. (Outlines of Industrial Chemistry.)	8vo,	*2 00
Humphrey, J. C. W. Metallography of Strain. (Metallurgy Series.) (In Press.)		
Humphreys, A. C. The Business Features of Engineering Practice.	8vo,	*1 25
Hunter, A. Bridge Work.....	8vo. (In Press.)	
Hurst, G. H. Handbook of the Theory of Color.....	8vo,	*2 50
— Dictionary of Chemicals and Raw Products.....	8vo,	*3 00
— Lubricating Oils, Fats and Greases.....	8vo,	*4 00
— Soaps.....	8vo,	*5 00
Hurst, G. H., and Simmons, W. H. Textile Soaps and Oils.....	8vo,	*2 50
Hurst, H. E., and Lattey, R. T. Text-book of Physics.....	8vo,	*3 00
— Also published in three parts.		
Part I. Dynamics and Heat.....		*1 25
Part II. Sound and Light.....		*1 25
Part III. Magnetism and Electricity.....		*1 50
Hutchinson, R. W., Jr. Long Distance Electric Power Transmission. 12mo,		*3 00
Hutchinson, R. W., Jr., and Thomas, W. A. Electricity in Mining. 12mo, (In Press.)		
Hutchinson, W. B. Patents and How to Make Money Out of Them. 12mo,		1 25
Hutton, W. S. Steam-boiler Construction.....	8vo,	6 00
— The Works' Manager's Handbook.....	8vo,	6 00

Hyde, E. W. Skew Arches. (Science Series No. 15.)	16mo,	0 50
Hyde, F. S. Solvents, Oils, Gums, Waxes.	8vo,	*2 00
Induction Coils. (Science Series No. 53.)	16mo,	0 50
Ingham, A. E. Gearing. A practical treatise.	8vo,	*2 50
Ingle, H. Manual of Agricultural Chemistry	8vo,	*3 00
Inness, C. H. Problems in Machine Design	12mo,	*2 00
— Air Compressors and Blowing Engines	12mo,	*2 00
— Centrifugal Pumps	12mo,	*2 00
— The Fan	12mo,	*2 00
Isherwood, B. F. Engineering Precedents for Steam Machinery	8vo,	2 50
Ivatts, E. B. Railway Management at Stations	8vo,	*2 50
Jacob, A., and Gould, E. S. On the Designing and Construction of Storage Reservoirs. (Science Series No. 6.)	16mo,	0 50
Jannettaz, E. Guide to the Determination of Rocks. Trans. by G. W. Plympton	12mo,	1 50
Jehl, F. Manufacture of Carbons	8vo,	*4 00
Jennings, A. S. Commercial Paints and Painting. (Westminster Series.)	8vo,	*2 00
Jennison, F. H. The Manufacture of Lake Pigments	8vo,	*3 00
Jepson, G. Cams and the Principles of their Construction	8vo,	*1 50
— Mechanical Drawing	8vo (In Preparation.)	
Jervis-Smith, F. J. Dynamometers	8vo,	*3 50
Jockin, W. Arithmetic of the Gold and Silversmith	12mo,	*1 00
Johnson, J. H. Arc Lamps and Accessory Apparatus. (Installation Manuals Series.)	12mo,	*0 75
Johnson, T. M. Ship Wiring and Fitting. (Installation Manuals Series.)	12mo,	*0 75
Johnson, W. McA. The Metallurgy of Nickel	(In Preparation.)	
Johnston, J. F. W., and Cameron, C. Elements of Agricultural Chemistry and Geology	12mo,	2 60
Joly, J. Radioactivity and Geology	12mo,	*3 00
Jones, H. C. Electrical Nature of Matter and Radioactivity	12mo,	*2 00
— Evolution of Solutions	(In Press.)	
— New Era in Chemistry	12mo,	*2 00
Jones, J. H. Tinplate Industry	8vo,	*3 00
Jones, M. W. Testing Raw Materials Used in Paint	12mo,	*2 00
Jordan, L. C. Practical Railway Spiral	12mo, leather,	*1 50
Joynson, F. H. Designing and Construction of Machine Gearing	8vo,	2 00
Jüptner, H. F. V. Siderology: The Science of Iron	8vo,	*5 00
Kansas City Bridge	4to,	6 00
Kapp, G. Alternate Current Machinery. (Science Series No. 96.)	16mo,	0 50
Keim, A. W. Prevention of Dampness in Buildings	8vo,	*2 00
Keller, S. S. Mathematics for Engineering Students. 12mo, half leather.		
— Algebra and Trigonometry, with a Chapter on Vectors		*1 75
— Plane and Solid Geometry		*1 25
— and Knox, W. E. Analytical Geometry and Calculus		*2 00
Kelsey, W. R. Continuous-current Dynamos and Motors	8vo,	*2 50

Kemble, W. T., and Underhill, C. R. The Periodic Law and the Hydrogen Spectrum	8vo, paper,	*0 50
Kemp, J. F. Handbook of Rocks	8vo,	*1 50
Kendall, E. Twelve Figure Cipher Code	4to,	*12 50
Kennedy, A. B. W., and Thurston, R. H. Kinematics of Machinery. (Science Series No. 54.)	16mo,	0 50
Kennedy, A. B. W., Unwin, W. C., and Idell, F. E. Compressed Air. (Science Series No. 106.)	16mo,	0 50
Kennedy, R. Modern Engines and Power Generators. Six Volumes. 4to,		15 00
Single Volumes	each,	3 00
— Electrical Installations. Five Volumes	4to,	15 00
Single Volumes	each,	3 50
— Flying Machines; Practice and Design	12mo,	*2 00
— Principles of Aeroplane Construction	8vo,	*1 50
Kennelly, A. E. Electro-dynamic Machinery	8vo,	1 50
Kent, W. Strength of Materials. (Science Series No. 41.)	16mo,	0 50
Kershaw, J. B. C. Fuel, Water and Gas Analysis	8vo,	*2 50
— Electrometallurgy. (Westminster Series.)	8vo,	*2 00
— The Electric Furnace in Iron and Steel Production	12mo,	*1 50
— Electro-Thermal Methods of Iron and Steel Production	8vo,	*3 00
Kindelan, J. Trackman's Helper	12mo,	*1 50
Kinzbrunner, C. Alternate Current Windings	8vo,	*1 50
— Continuous Current Armatures	8vo,	*1 50
— Testing of Alternating Current Machines	8vo,	*2 00
Kirkaldy, W. G. David Kirkaldy's System of Mechanical Testing. 4to,		10 00
Kirkbride, J. Engraving for Illustration	8vo,	*1 50
Kirkham, J. E. Structural Engineering	8vo,	*5 00
Kirkwood, J. P. Filtration of River Waters	4to,	7 50
Kirschke, A. Gas and Oil Engines	12mo,	*1 25
Klein, J. F. Design of a High-speed Steam-engine	8vo,	*5 00
— Physical Significance of Entropy	8vo,	*1 50
Kleinbans, F. B. Boiler Construction	8vo,	3 00
Knight, R.-Adm. A. M. Modern Seamanship	8vo,	*7 50
Half morocco		*9 00
Knott, C. G., and Mackay, J. S. Practical Mathematics	8vo,	2 00
Knox, J. Physico-Chemical Calculations	12mo,	*1 00
— Fixation of Atmospheric Nitrogen. (Chemical Monographs.)	12mo,	*0 75
Koester, F. Steam-Electric Power Plants	4to,	*5 00
— Hydroelectric Developments and Engineering	4to,	*5 00
Koller, T. The Utilization of Waste Products	8vo,	*3 00
— Cosmetics	8vo,	*2 50
Kremann, R. Application of the Physico-Chemical Theory to Technical Processes and Manufacturing Methods. Trans. by H. E. Potts	8vo,	*2 50
Kretschmar, K. Yarn and Warp Sizing	8vo,	*4 00
Lallier, E. V. Elementary Manual of the Steam Engine	12mo,	*2 00
Lambert, T. Lead and Its Compounds	8vo,	*3 50
— Bone Products and Manures	8vo,	*3 00

D. VAN NOSTRAND CO.'S SHORT TITLE CATALOG 17

Lamborn, L. L. Cottonseed Products	8vo,	*3 00
— Modern Soaps, Candles, and Glycerin	8vo,	*7 50
Lamprecht, R. Recovery Work After Pit Fires. Trans. by C. Salter. 8vo,		*4 00
Lancaster, M. Electric Cooking, Heating and Cleaning.	8vo,	*1 50
Lanchester, F. W. Aerial Flight. Two Volumes. 8vo.		
Vol. I. Aerodynamics.		*6 00
— Aerial Flight. Vol. II. Aerodonetics.		*6.00
Lange, K. R. By-Products of Coal-Gas Manufacture.	12mo,	2 00
Larner, E. T. Principles of Alternating Currents.	12mo.	*1 25
La Rue, B. F. Swing Bridges. (Science Series No. 107.)	16mo,	0 50
Lassar-Cohn, Dr. Modern Scientific Chemistry. Trans. by M. M.		
Pattison Muir	12mo,	*2 00
Latimer, L. H., Field, C. J., and Howell, J. W. Incandescent Electric		
Lighting. (Science Series No. 57.)	16mo,	0 50
Latta, M. N. Handbook of American Gas-Engineering Practice . . 8vo,		*4 50
— American Producer Gas Practice	4to,	*6 00
Laws, B. C. Stability and Equilibrium of Floating Bodies.	8vo,	*3 50
Lawson, W. R. British Railways. A Financial and Commercial		
Survey.	8vo,	2 00
Leask, A. R. Breakdowns at Sea	12mo,	2 00
— Refrigerating Machinery	12mo,	2 00
Lecky, S. T. S. "Wrinkles" in Practical Navigation.	8vo,	*8 00
Le Doux, M. Ice-Making Machines. (Science Series No. 46.) . 16mo,		0 50
Leeds, C. C. Mechanical Drawing for Trade Schools. (Machinery		
Trades Edition.)	oblong 4to	*2 00
— Mechanical Drawing for High and Vocational Schools.	4to,	*1 50
Lefèvre, L. Architectural Pottery. Trans. by H. K. Bird and W. M.		
Binns	4to,	*7 50
Lehner, S. Ink Manufacture. Trans. by A. Morris and H. Robson. 8vo,		*2 50
Lemstrom, S. Electricity in Agriculture and Horticulture.	8vo,	*1 50
Letts, E. A. Fundamental Problems in Chemistry.	8vo,	*2 00
Le Van, W. B. Steam-Engine Indicator. (Science Series No. 78.) 16mo,		0 50
Lewes, V. B. Liquid and Gaseous Fuels. (Westminster Series.) 8vo,		*2 00
— Carbonization of Coal	8vo,	*3 00
Lewis, L. P. Railway Signal Engineering	8vo,	*3 50
Lieber, B. F. Lieber's Standard Telegraphic Code	8vo,	*10 00
— Code. German Edition	8vo,	*10 00
— — Spanish Edition	8vo,	*10 00
— — French Edition	8vo,	*10 00
— Terminal Index	8vo,	*2 50
— Lieber's Appendix	folio,	*15 00
— — Handy Tables.	4to,	*2 50
— Bankers and Stockbrokers' Code and Merchants and Shippers'		
Blank Tables	8vo,	*15 00
— 100,000,000 Combination Code	8vo,	*10 00
— Engineering Code	8vo,	*12 50
Livermore, V. P., and Williams, J. How to Become a Competent Motor-		
man	12mo,	*1 00
Livingstone, R. Design and Construction of Commutators	8vo,	*2 25
— Mechanical Design and Construction of Generators.	8vo,	*3 50
Lobben, P. Machinists' and Draftsmen's Handbook.	8vo,	2 50

18 D. VAN NOSTRAND CO.'S SHORT TITLE CATALOG

Lockwood, T. D. Electricity, Magnetism, and Electro-telegraph	8vo,	2 50
Lockwood, T. D. Electrical Measurement and the Galvanometer	12mo,	0 75
Lodge, O. J. Elementary Mechanics	12mo,	1 50
— Signalling Across Space without Wires	8vo,	*2 00
Loewenstein, L. C., and Crissey, C. P. Centrifugal Pumps		*4 50
Lomax, J. W. Cotton Spinning	12mo,	1 50
Lord, R. T. Decorative and Fancy Fabrics	8vo,	*3 50
Loring, A. E. A Handbook of the Electromagnetic Telegraph	16mo	0 50
— Handbook. (Science Series No. 39.)	16m,	0 50 ⁰
Lovell, D. H. Practical Switchwork	12mo,	*1 00
Low, D. A. Applied Mechanics (Elementary)	16mo,	0 80
Lubschez, B. J. Perspective	12mo,	*1 50
Lucke, C. E. Gas Engine Design	8vo,	*3 00
— Power Plants: Design, Efficiency, and Power Costs. 2 vols.		
	(In Preparation.)	
Luckiesh, M. Color and Its Application	8vo. (In Press.)	
Lunge, G. Coal-tar and Ammonia. Two Volumes	8vo,	*15 00
— Technical Gas Analysis	8vo,	*4 00
— Manufacture of Sulphuric Acid and Alkali. Four Volumes	8vo,	
Vol. I. Sulphuric Acid. In three parts		*18 00
Vol. II. Salt Cake, Hydrochloric Acid and Leblanc Soda. In two parts		*15 00
Vol. III. Ammonia Soda		*10 00
Vol. IV. Electrolytic Methods	(In Press.)	
— Technical Chemists' Handbook	12mo, leather,	*3 50
— Technical Methods of Chemical Analysis. Trans. by C. A. Keane in collaboration with the corps of specialists.		
Vol. I. In two parts	8vo,	*15 00
Vol. II. In two parts	8vo,	*18 00
Vol. III. In two parts	8vo,	*18 00
The set (3 vols.) complete		*48 00
Luquer, L. M. Minerals in Rock Sections	8vo,	*1 50
Macaulay, J., and Hall, C. Modern Railway Working, 8 vols.	4to,	20 00
Each volume separately		3 00
Macewen, H. A. Food Inspection	8vo,	*2 50
Mackenzie, N. F. Notes on Irrigation Works	8vo,	*2 50
Mackie, J. How to Make a Woolen Mill Pay	8vo,	*2 00
Mackrow, C. Naval Architect's and Shipbuilder's Pocket-book	16mo, leather,	5 00.
Maguire, Wm. R. Domestic Sanitary Drainage and Plumbing	8vo,	4 00
Malcolm, C. W. Textbook on Graphic Statics	8vo,	*3 00
Malcolm, H. W. Submarine Telegraph Cable	(In Press.)	
Mallet, A. Compound Engines. Trans. by R. R. Buel. (Science Series No. 10.)	16mo,	
Mansfield, A. N. Electro-magnets. (Science Series No. 64.)	16mo,	0 50
Marks, E. C. R. Construction of Cranes and Lifting Machinery	12mo,	*1 50
— Construction and Working of Pumps	12mo,	*1 50

— Manufacture of Iron and Steel Tubes	12mo,	*2 00
— Mechanical Engineering Materials	12mo,	*1 00
Marks, G. C. Hydraulic Power Engineering	8vo,	3 50
— Inventions, Patents and Designs	12mo,	*1 00
Marlow, T. G. Drying Machinery and Practice	8vo,	*5 00
Marsh, C. F. Concise Treatise on Reinforced Concrete	8vo,	*2 50
— Reinforced Concrete Compression Member Diagram. Mounted on Cloth Boards		*1. 50
Marsh, C. F., and Dunn, W. Manual of Reinforced Concrete and Con- crete Block Construction	16mo, morocco,	*2 50
Marshall, W. J., and Sankey, H. R. Gas Engines. (Westminster Series.) 8vo,		*2 00
Martin, G. Triumphs and Wonders of Modern Chemistry	8vo,	*2 00
— Modern Chemistry and Its Wonders (In Press.)		
Martin, N. Properties and Design of Reinforced Concrete	12mo,	*2 50
Martin, W. D. Hints to Engineers	12mo,	*1 00
Massie, W. W., and Underhill, C. R. Wireless Telegraphy and Telephony. 12mo,		*1 00
Matheson, D. Australian Saw-Miller's Log and Timber Ready Reckoner. 12mo, leather,		1 50
Mathot, R. E. Internal Combustion Engines	8vo,	*6 00
Maurice, W. Electric Blasting Apparatus and Explosives	8vo,	*3 50
— Shot Firer's Guide	8vo,	*1 50
Maxwell, J. C. Matter and Motion. (Science Series No. 36.) 16mo,		0 50
Maxwell, W. H., and Brown, J. T. Encyclopedia of Municipal and Sani- tary Engineering	4to,	*10 00
Mayer, A. M. Lecture Notes on Physics	8vo,	2 00
Mayer, C., and Slippery, J. C. Telephone Line Construction	8vo,	*3 00
McCullough, E. Practical Surveying	12mo,	*2 00
— Engineering Work in Cities and Towns	8vo,	*3 00
— Reinforced Concrete	12mo,	*1 50
McCullough, R. S. Mechanical Theory of Heat	8vo,	3 50
McGibbon, W. C. Indicator Diagrams for Marine Engineers	8vo,	*3 00
— Marine Engineers' Drawing Book	oblong 4to,	*2 00
McIntosh, J. G. Technology of Sugar	8vo,	*4 50
— Industrial Alcohol	8vo,	*3 00
— Manufacture of Varnishes and Kindred Industries. Three Volumes. 8vo.		
Vol. I. Oil Crushing, Refining and Boiling		*3 50
Vol. II. Varnish Materials and Oil Varnish Making		*4 00
Vol. III. Spirit Varnishes and Materials		*4 50
McKnight, J. D., and Brown, A. W. Marine Multitubular Boilers		*1 50
McMaster, J. B. Bridge and Tunnel Centres. (Science Series No. 20.) 16mo,		0 50
McMechen, F. L. Tests for Ores, Minerals and Metals	12mo,	*1 00
McPherson, J. A. Water-works Distribution	8vo,	2 50
Meade, R. K. Design and Equipment of Small Chemical Laboratories, 8vo,		
Melick, C. W. Dairy Laboratory Guide	12mo,	*1 25

Mensch, L. J. Reinforced Concrete Pocket Book.....	16mo, leather,	*4 00
Merck, E. Chemical Reagents; Their Purity and Tests. Trans. by H. E. Schenck.....	8vo,	1 00
Merivale, J. H. Notes and Formulae for Mining Students.....	12mo,	1 50
Merritt, Wm. H. Field Testing for Gold and Silver.....	16mo, leather,	1 50
Meyer, J. G. A., and Pecker, C. G. Mechanical Drawing and Machine Design.....	4to,	5 00
Mierzinski, S. Waterproofing of Fabrics. Trans. by A. Morris and H. Robson.....	8vo,	*2 50
Miessner, B. F. Radio Dynamics.....	(In Press.)	
Miller, G. A. Determinants. (Science Series No 105.).....	16mo,	
Milroy, M. E. W. Home Lace-making.....	12mo,	*1 00
Mitchell, C. A. Mineral and Aerated Waters.....	8vo,	*3 00
Mitchell, C. A., and Prideaux, R. M. Fibres Used in Textile and Allied Industries.....	8vo,	*3 00
Mitchell, C. F., and G. A. Building Construction and Drawing. 12mo. Elementary Course.....		*1 50
Advanced Course.....		*2 50
Monckton, C. C. F. Radiotelegraphy. (Westminster Series.)....	8vo,	*2 00
Monteverde, R. D. Vest Pocket Glossary of English-Spanish, Spanish- English Technical Terms.....	64mo, leather,	*1 00
Montgomery, J. H. Electric Wiring Specifications.....	16mo,	*1 00
Moore, E. C. S. New Tables for the Complete Solution of Ganguillet and Kutter's Formula.....	8vo,	*5 00
Morecroft, J. H., and Hehre, F. W. Short Course in Electrical Testing. 8vo,		*1 50
Morgan, A. P. Wireless Telegraph Apparatus for Amateurs.....	12mo,	*1 50
Moses, A. J. The Characters of Crystals.....	8vo,	*2 00
— and Parsons, C. L. Elements of Mineralogy.....	8vo,	*2 50
Moss, S.A. Elements of Gas Engine Design.(Science Series No.121.)	16mo,	0 50
— The Lay-out of Corliss Valve Gears. (Science Series No. 119.)	16mo,	0 50
Mulford, A. C. Boundaries and Landmarks.....	12mo,	*1 00
Mullin, J. P. Modern Moulding and Pattern-making.....	12mo,	2 50
Munby, A. E. Chemistry and Physics of Building Materials. (West- minster Series.).....	8vo,	*2 00
Murphy, J. G. Practical Mining.....	16mo,	1 00
Murphy, W. S. Textile Industries. Eight Volumes.....		*20 00
Sold separately, each,		*3 00
Murray, J. A. Soils and Manures. (Westminster Series.).....	8vo,	*2 00
Naquet, A. Legal Chemistry.....	12mo,	2 00
Nasmith, J. The Student's Cotton Spinning.....	8vo,	3 00
— Recent Cotton Mill Construction.....	12mo,	2 00
Neave, G. B., and Heilbron, I. M. Identification of Organic Compounds. 12mo,		*1 25
Neilson, R. M. Aeroplane Patents.....	8vo,	*2 00
Nerz, F. Searchlights. Trans. by C. Rodgers.....	8vo,	*3 00
Neuberger, H., and Noalhat, H. Technology of Petroleum. Trans. by J. G. McIntosh.....	8vo,	*10 00
Newall, J. W. Drawing, Sizing and Cutting Bevel-gears.....	8vo,	1 50

D. VAN NOSTRAND CO.'S SHORT TITLE CATALOG 21

Newbeking, T. Handbook for Gas Engineers and Managers.....	8vo,	*6 50
Newton, G. J. Underground Distribution Systems.....	(In Press.)	
Nicol, G. Ship Construction and Calculations.....	8vo,	*4 50
Nipher, F. E. Theory of Magnetic Measurements.....	12mo,	1 00
Nisbet, H. Grammar of Textile Design.....	8vo,	*3 00
Nolan, H. The Telescope. (Science Series No. 51.).....	16mo,	0 50
Noll, A. How to Wire Buildings.....	12mo,	1 50
North, H. B. Laboratory Experiments in General Chemistry.....	12mo,	*1 00
Nugent, E. Treatise on Optics.....	12mo,	1 50
O'Connor, H. The Gas Engineer's Pocketbook.....	12mo, leather,	3 50
— Petrol Air Gas.....	12mo,	*0 75
Ohm, G. S., and Lockwood, T. D. Galvanic Circuit. Translated by William Francis. (Science Series No. 102.).....	16mo,	0 50
Olsen, J. C. Text-book of Quantitative Chemical Analysis.....	8vo,	*4 00
Olsson, A. Motor Control, in Turret Turning and Gun Elevating. (U. S. Navy Electrical Series, No. 1.).....	12mo, paper,	*0 50
Ormsby, M. T. M. Surveying.....	12mo,	1 50
Oudin, M. A. Standard Polyphase Apparatus and Systems.....	8vo,	*3 00
Owen, D. Recent Physical Research.....	8vo,	*1 50
Pakes, W. C. C., and Nankivell, A. T. The Science of Hygiene..	8vo,	*1 75
Palaz, A. Industrial Photometry. Trans. by G. W. Patterson, Jr..	8vo,	*4 00
Pamely, C. Colliery Manager's Handbook.....	8vo,	*10 00
Parker, P. A. M. The Control of Water.....	8vo,	*5 00
Parr, G. D. A. Electrical Engineering Measuring Instruments....	8vo,	*3 50
Parry, E. J. Chemistry of Essential Oils and Artificial Perfumes..	8vo,	*5 00
— Foods and Drugs. Two Volumes.....	8vo,	
Vol. I. Chemical and Microscopical Analysis of Foods and Drugs.		*7 50
Vol. II. Sale of Food and Drugs Act.....		*3 00
— and Coste, J. H. Chemistry of Pigments.....	8vo,	*4 50
Parry, L. Notes on Alloys.....	8vo,	*3 00
— Metalliferous Wastes.....	8vo,	*2 00
— Analysis of Ashes and Alloys.....	8vo,	*2 00
Parry, L. A. Risk and Dangers of Various Occupations.....	8vo,	*3 00
Parshall, H. F., and Hobart, H. M. Armature Windings.....	4to,	*7 50
— Electric Railway Engineering.....	4to,	*10 00
Parsons, J. L. Land Drainage.....	8vo,	*1 50
Parsons, S. J. Malleable Cast Iron.....	8vo,	*2 50
Partington, J. R. Higher Mathematics for Chemical Students..	12mo,	*2 00
— Textbook of Thermodynamics.....	8vo,	*4 00
Passmore, A. C. Technical Terms Used in Architecture.....	8vo,	*3 50
Patchell, W. H. Electric Power in Mines.....	8vo,	*4 00
Paterson, G. W. L. Wiring Calculations.....	12mo,	*2 00
— Electric Mine Signalling Installations.....	12mo,	*1 50
Patterson, D. The Color Printing of Carpet Yarns.....	8vo,	*3 50
— Color Matching on Textiles.....	8vo,	*3 00
— Textile Color Mixing.....	8vo,	*3 00
Paulding, C. P. Condensation of Steam in Covered and Bare Pipes..	8vo,	*2 00
— Transmission of Heat through Cold-storage Insulation.....	12mo,	*1 00

Payne, D. W. Iron Founders' Handbook.....(<i>In Press</i>)		
Peckham, S. F. Solid Bitumens.....	8vo,	*5 00
Peddie, R. A. Engineering and Metallurgical Books.....	12mo,	*1 50
Peirce, B. System of Analytic Mechanics.....	4to,	10 00
Pendred, V. The Railway Locomotive. (<i>Westminster Series</i>)....	8vo,	*2 00
Perkin, F. M. Practical Methods of Inorganic Chemistry.....	12mo,	*1 00
— and Jagers, E. M. Elementary Chemistry.....	12mo,	*1 00
Perrigo, O. E. Change Gear Devices.....	8vo,	1 00
Perrine, F. A. C. Conductors for Electrical Distribution.....	8vo,	*3 50
Petit, G. White Lead and Zinc White Paints.....	8vo,	*1 50
Petit, R. How to Build an Aeroplane. Trans. by T. O'B. Hubbard, and J. H. Ledebuer.....	8vo,	*1 50
Pettit, Lieut. J. S. Graphic Processes. (<i>Science Series No. 76</i>)....	16mo,	0 50
Philbrick, P. H. Beams and Girders. (<i>Science Series No. 88</i>)....	16mo,	
Phillips, J. Gold Assaying.....	8vo,	*2 50
— Dangerous Goods.....	8vo,	3 50
Phin, J. Seven Follies of Science.....	12mo,	*1 25
Pickworth, C. N. The Indicator Handbook. Two Volumes. 12mo, each,		1 50
— Logarithms for Beginners.....	12mo. boards,	0 50
— The Slide Rule.....	12mo,	1 00
Plattner's Manual of Blow-pipe Analysis. Eighth Edition, revised. Trans. by H. B. Cornwall.....	8vo,	*4 00
Plympton, G. W. The Aneroid Barometer. (<i>Science Series No. 35</i>) 16mo,		0 50
— How to become an Engineer. (<i>Science Series No. 100</i>).....	16mo,	0 50
— Van Nostrand's Table Book. (<i>Science Series No. 104</i>).....	16mo,	0 50
Pochet, M. L. Steam Injectors. Translated from the French. (<i>Science Series No. 29</i>).....	16mo,	0 50
Pocket Logarithms to Four Places. (<i>Science Series No. 65</i>).....	16mo,	0 50
	leather,	1 00
Polleyn, F. Dressings and Finishings for Textile Fabrics.....	8vo,	*3 00
Pope, F. G. Organic Chemistry.....	12mo,	*2 25
Pope, F. L. Modern Practice of the Electric Telegraph.....	8vo,	1 50
Popplewell, W. C. Prevention of Smoke.....	8vo,	*3 50
— Strength of Materials.....	8vo,	*1 75
Porritt, B. D. The Chemistry of Rubber. (<i>Chemical Monographs, No. 3</i>).....	12mo,	*0 75
Porter, J. R. Helicopter Flying Machine.....	12mo,	*1 25
Potts, H. E. Chemistry of the Rubber Industry. (<i>Outlines of Indus- trial Chemistry</i>).....	8vo,	*2 00
Practical Compounding of Oils, Tallow and Grease.....	8vo,	*3 50
Pratt, K. Boiler Draught.....	12mo,	*1 25
— High Speed Steam Engines.....	8vo,	*2 00
Pray, T., Jr. Twenty Years with the Indicator.....	8vo,	2 50
— Steam Tables and Engine Constant.....	8vo,	2 00
Prelini, C. Earth and Rock Excavation.....	8vo,	*3 00
— Graphical Determination of Earth Slopes.....	8vo,	*2 00
— Tunneling. New Edition.....	8vo,	*3 00
— Dredging. A Practical Treatise.....	8vo,	*3 00
Prescott, A. B. Organic Analysis.....	8vo,	5 00
Prescott, A. B., and Johnson, O. C. Qualitative Chemical Analysis. .	8vo,	*3 50

Prescott, A. B., and Sullivan, E. C. First Book in Qualitative Chemistry.	12mo,	*1 50
Prideaux, E. B. R. Problems in Physical Chemistry.....	8vo,	*2 00
Primrose, G. S. C. Zinc. (Metallurgy Series.).....	(In Press.)	
Pullen, W. W. F. Application of Graphic Methods to the Design of Structures.....	12mo,	*2 50
— Injectors: Theory, Construction and Working.....	12mo,	*1 50
— Indicator Diagrams	8vo,	*2 50
— Engine Testing	8vo,	*4 50
Pulsifer, W. H. Notes for a History of Lead.....	8vo,	4 00
Putsch, A. Gas and Coal-dust Firing.....	8vo,	*3 00
Pynchon, T. R. Introduction to Chemical Physics.....	8vo,	3 00
Rafter G. W. Mechanics of Ventilation. (Science Series No. 33.)	16mo,	0 50
— Potable Water. (Science Series No. 103.).....	16mo,	0 50
— Treatment of Septic Sewage. (Science Series No. 118.)	16mo,	0 50
Rafter, G. W., and Baker, M. N. Sewage Disposal in the United States.	4to,	*6 00
Raikes, H. P. Sewage Disposal Works	8vo,	*4 00
Randall, P. M. Quartz Operator's Handbook.....	12mo,	2 00
Randau, P. Enamels and Enamelling.....	8vo,	*4 00
Rankine, W. J. M. Applied Mechanics.....	8vo,	5 00
— Civil Engineering.....	8vo,	6 50
— Machinery and Millwork.....	8vo,	5 00
— The Steam-engine and Other Prime Movers.....	8vo,	5 00
Rankine, W. J. M., and Bamber, E. F. A Mechanical Text-book...	8vo,	3 50
Raphael, F. C. Localization of Faults in Electric Light and Power Mains.	8vo,	*3 00
Rasch, E. Electric Arc Phenomena. Trans. by K. Tornberg.....	8vo,	*2 00
Rathbone, R. L. B. Simple Jewellery.....	8vo,	*2 00
Rateau, A. Flow of Steam through Nozzles and Orifices. Trans. by H. B. Brydon.....	8vo	*1 50
Rausenberger, F. The Theory of the Recoil of Guns.....	8vo,	*4 50
Rautenstrauch, W. Notes on the Elements of Machine Design.	8vo, boards,	*1 50
Rautenstrauch, W., and Williams, J. T. Machine Drafting and Empirical Design.		
Part I. Machine Drafting.....	8vo,	*1 25
Part II. Empirical Design.....	(In Preparation.)	
Raymond, E. B. Alternating Current Engineering.....	12mo,	*2 50
Rayner, H. Silk Throwing and Waste Silk Spinning.....	8vo,	*2 50
Recipes for the Color, Paint, Varnish, Oil, Soap and Drysaltery Trades.	8vo,	*3 50
Recipes for Flint Glass Making.....	12mo,	*4 50
Redfern, J. B., and Savin, J. Bells, Telephones (Installation Manuals Series.).....	16mo,	*0 50
Redgrove, H. S. Experimental Mensuration.....	12mo,	*1 25
Redwood, B. Petroleum. (Science Series No. 92.).....	16mo,	0 50
Reed, S. Turbines Applied to Marine Propulsion.....		*5 00
Reed's Engineers' Handbook.....	8vo,	*5 00
— Key to the Nineteenth Edition of Reed's Engineers' Handbook.	8vo,	*3 00
— Useful Hints to Sea-going Engineers.....	12mo,	1 50
— Guide to the Use of the Slide Valve.....	12mo,	*1 60

Reid, E. E. Introduction to Research in Organic Chemistry. (<i>In Press.</i>)	
Reid, H. A. Concrete and Reinforced Concrete Construction.....8vo,	*5 00
Reinhardt, C. W. Lettering for Draftsmen, Engineers, and Students.	
oblong 4to, boards,	1 00
— The Technic of Mechanical Drafting..... oblong 4to, boards,	*1 00
Reiser, F. Hardening and Tempering of Steel. Trans. by A. Morris and H. Robson..... 12mo,	*2 50
Reiser, N. Faults in the Manufacture of Woolen Goods. Trans. by A. Morris and H. Robson..... 8vo,	*2 50
— Spinning and Weaving Calculations..... 8vo,	*5 00
Renwick, W. G. Marble and Marble Working..... 8vo,	5 00
Reuleaux, F. The Constructor. Trans. by H. H. Suplee..... 4to,	*4 00
Reuterdahl, A. Theory and Design of Reinforced Concrete Arches. 8vo,	*2 00
Reynolds, O., and Idell, F. E. Triple Expansion Engines. (Science Series No. 99.)..... 16mo,	0 50
Rhead, G. F. Simple Structural Woodwork..... 12mo,	*1 00
Rhodes, H. J. Art of Lithography..... 8vo,	3 50
Rice, J. M., and Johnson, W. W. A New Method of Obtaining the Differ- ential of Functions..... 12mo,	0 50
Richards, W. A. Forging of Iron and Steel..... (<i>In Press.</i>)	
Richards, W. A., and North, H. B. Manual of Cement Testing... 12mo,	*1 50
Richardson, J. The Modern Steam Engine..... 8vo,	*3 50
Richardson, S. S. Magnetism and Electricity..... 12mo,	*2 00
Rideal, S. Glue and Glue Testing..... 8vo,	*4 00
Rimmer, E. J. Boiler Explosions, Collapses and Mishaps..... 8vo,	*1 75
Rings, F. Concrete in Theory and Practice..... 12mo,	*2 50
— Reinforced Concrete Bridges..... 4to,	*5 00
Ripper, W. Course of Instruction in Machine Drawing..... folio,	*6 00
Roberts, F. C. Figure of the Earth. (Science Series No. 79.)..... 16mo,	0 50
Roberts, J., Jr. Laboratory Work in Electrical Engineering..... 8vo,	*2 00
Robertson, L. S. Water-tube Boilers..... 8vo,	2 00
Robinson, J. B. Architectural Composition..... 8vo,	*2 50
Robinson, S. W. Practical Treatise on the Teeth of Wheels. (Science Series No. 24.)..... 16mo,	0 50
— Railroad Economics. (Science Series No. 59.)..... 16mo,	0 50
— Wrought Iron Bridge Members. (Science Series No. 60.)..... 16mo,	0 50
Robson, J. H. Machine Drawing and Sketching..... 8vo,	*1 50
Roebing, J. A. Long and Short Span Railway Bridges..... folio,	25 00
Rogers, A. A Laboratory Guide of Industrial Chemistry..... 12mo,	*1 50
Rogers, A. Industrial Chemistry..... 8vo,	*5 00
Rogers, F. Magnetism of Iron Vessels. (Science Series No. 30.) 16mo,	0 50
Rohland, P. Colloidal and Crystalloidal State of Matter. Trans. by W. J. Britland and H. E. Potts..... 12mo,	*1 25
Rollins, W. Notes on X-Light..... 8vo,	*5 00
Rollinson, C. Alphabets..... Oblong, 12mo,	*1 00
Rose, J. The Pattern-makers' Assistant..... 8vo,	2 50
— Key to Engines and Engine-running..... 12mo,	2 50
Rose, T. K. The Precious Metals. (Westminster Series.)..... 8vo,	*2 00
Rosenhain, W. Glass Manufacture. (Westminster Series.)..... 8vo,	*2 00
— Physical Metallurgy, An Introduction to. (Metallurgy Series.) 8vo, (<i>In Press.</i>)	

D. VAN NOSTRAND CO.'S SHORT TITLE CATALOG 25

Ross, W. A. Blowpipe in Chemistry and Metallurgy	12mo,	*2 00
Roth. Physical Chemistry	8vo,	*2 00
Rothery, G. C., and Edmonds, H. O. The Modern Laundry, 2 vols., 4to, half leather,		*12 00
Rouillion, L. The Economics of Manual Training	8vo,	2 00
Rowan, F. J. Practical Physics of the Modern Steam-boiler	8vo,	*3 00
— and Idell, F. E. Boiler Incrustation and Corrosion. (Science Series No. 27.)	16mo,	0 50
Roxburgh, W. General Foundry Practice. (Westminster Series.)	8vo,	*2 00
Ruhmer, E. Wireless Telephony. Trans. by J. Erskine-Murray	8vo,	*3 50
Russell, A. Theory of Electric Cables and Networks	8vo,	*3 00
Sabine, R. History and Progress of the Electric Telegraph	12mo,	1 25
Sanford, P. G. Nitro-explosives	8vo,	*4 00
Saunders, C. H. Handbook of Practical Mechanics	16mo,	1 00
	leather,	1 25
Sayers, H. M. Brakes for Tram Cars	8vo,	*1 25
Scheele, C. W. Chemical Essays	8vo,	*2 00
Scheithauer, W. Shale Oils and Tars	8vo,	*3 50
Schellen, H. Magneto-electric and Dynamo-electric Machines	8vo,	5 00
Scherer, R. Casein. Trans. by C. Salter	8vo,	*3 00
Schidrowitz, P. Rubber, Its Production and Industrial Uses	8vo,	*5 00
Schindler, K. Iron and Steel Construction Works.	12mo,	*1 25
Schmall, C. N. First Course in Analytic Geometry, Plane and Solid. 12mo, half leather,		*1 75
Schmall, C. N., and Shack, S. M. Elements of Plane Geometry.	12mo,	*1 25
Schmeer, L. Flow of Water	8vo,	*3 00
Schumann, F. A Manual of Heating and Ventilation	12mo, leather,	1 50
Schwarz, E. H. L. Causal Geology	8vo,	*2 50
Schweizer, V. Distillation of Resins	8vo,	*3 50
Scott, W. W. Qualitative Analysis. A Laboratory Manual	8vo,	*1 50
Scribner, J. M. Engineers' and Mechanics' Companion	16mo, leather,	1 50
Scudder, H. Electrical Conductivity and Ionization Constants of Organic Compounds	8vo,	*3 00
Searle, A. B. Modern Brickmaking	8vo,	*5 00
— Cement, Concrete and Bricks	8vo,	*3 00
Searle, G. M. "Sumners' Method." Condensed and Improved. (Science Series No. 124.)	16mo,	0 50
Seaton, A. E. Manual of Marine Engineering	8vo	8 00
Seaton, A. E., and Rounthwaite, H. M. Pocket-book of Marine Engi- neering	16mo, leather,	3 50
Seeligmann, T., Torrilhon, G. L., and Falconnet, H. India Rubber and Gutta Percha. Trans. by J. G. McIntosh	8vo,	*5 00
Seidell, A. Solubilities of Inorganic and Organic Substances	8vo,	*3 00
Seligman, R. Aluminum. (Metallurgy Series.)	(In Press.)	
Sellew, W. H. Steel Rails	4to,	*12 50
— Railway Maintenance	(In Press.)	
Senter, G. Outlines of Physical Chemistry	12mo,	*1 75
— Text-book of Inorganic Chemistry	12mo,	*1 75

Sever, G. F. Electric Engineering Experiments.....	.8vo, boards,	*1 00
Sever, G. F., and Townsend, F. Laboratory and Factory Tests in Electrical Engineering.....	.8vo,	*2 50
Sewall, C. H. Wireless Telegraphy.....	.8vo,	*2 00
— Lessons in Telegraphy.....	12mo,	*1 00
Sewell, T. The Construction of Dynamos.....	.8vo,	*3 00
Sexton, A. H. Fuel and Refractory Materials.....	12mo,	*2 50
— Chemistry of the Materials of Engineering.....	12mo,	*2 50
— Alloys (Non-Ferrous).....	.8vo,	*3 00
— The Metallurgy of Iron and Steel.....	.8vo,	*6 50
Seymour, A. Modern Printing Inks.....	.8vo,	*2 00
Shaw, Henry S. H. Mechanical Integrators. (Science Series No. 83.)	16mo,	0 50
Shaw, S. History of the Staffordshire Potteries.....	.8vo,	2 00
— Chemistry of Compounds Used in Porcelain Manufacture....	.8vo,	*5 00
Shaw, W. N. Forecasting Weather.....	.8vo,	*3 50
Sheldon, S., and Hausmann, E. Direct Current Machines.....	12mo,	*2 50
— Alternating Current Machines.....	12mo,	*2 50
Sheldon, S., and Hausmann, E. Electric Traction and Transmission Engineering.....	12mo,	*2 50
Shields, J. E. Notes on Engineering Construction.....	12mo,	1 50
Shreve, S. H. Strength of Bridges and Roofs.....	.8vo,	3 50
Shunk, W. F. The Field Engineer.....	12mo, morocco,	2 50
Simmons, W. H., and Appleton, H. A. Handbook of Soap Manufacture,	.8vo,	*3 00
Simmons, W. H., and Mitchell, C. A. Edible Fats and Oils.....	.8vo,	*3 00
Simpson, G. The Naval Constructor.....	12mo, morocco,	*5 00
Simpson, W. Foundations.....	.8vo. (<i>In Press.</i>)	
Sinclair, A. Development of the Locomotive Engine..	.8vo, half leather,	5 00
Sindall, R. W., and Bacon, W. N. The Testing of Wood Pulp....	.8vo,	*2 50
Sindall, R. W. Manufacture of Paper. (Westminster Series.)...	.8vo,	*2 00
Sloane, T. O'C. Elementary Electrical Calculations.....	12mo,	*2 00
Smallwood, J. C. Mechanical Laboratory Methods. (Van Nostrand's Textbooks.)	12mo, leather,	*2 50
Smith, C. A. M. Handbook of Testing, MATERIALS.....	.8vo,	*2 50
Smith, C. A. M., and Warren, A. G. New Steam Tables.....	.8vo,	*1 25
Smith, C. F. Practical Alternating Currents and Testing.....	.8vo,	*2 50
— Practical Testing of Dynamos and Motors.....	.8vo,	*2 00
Smith, F. A. Railway Curves.....	12mo,	*1 00
— Standard Turnouts on American Railroads.....	12mo,	*1 00
— Maintenance of Way Standards.....	12mo,	*1 50
Smith, F. E. Handbook of General Instruction for Mechanics...	12mo,	1 50
Smith, H. G. Minerals and the Microscope.....	12mo,	*1 25
Smith, J. C. Manufacture of Paint.....	.8vo,	*3 50
Smith, R. H. Principles of Machine Work.....	12mo,	*3 00
— Elements of Machine Work.....	12mo,	*2 00
Smith, W. Chemistry of Hat Manufacturing.....	12mo,	*3 00
Snell, A. T. Electric Motive Power.....	.8vo,	*4 00
Snow, W. G. Pocketbook of Steam Heating and Ventilation. (<i>In Press.</i>)		

Snow, W. G., and Nolan, T. Ventilation of Buildings. (Science Series No. 5.)	16mo,	0 50
Soddy, F. Radioactivity	8vo,	*3 00
Solomon, M. Electric Lamps. (Westminster Series.)	8vo,	*2 00
Somerscales, A. N. Mechanics for Marine Engineers	12mo,	*1 50
— Mechanical and Marine Engineering Science	8vo,	*5 00
Sothorn, J. W. The Marine Steam Turbine	8vo,	*5 00
— Verbal Notes and Sketches for Marine Engineers	8vo,	*5 00
Sothorn, J. W., and Sothorn, R. M. Elementary Mathematics for Marine Engineers	12mo,	*1 00
— Simple Problems in Marine Engineering Design	12mo,	*1 00
Southcombe, J. E. Chemistry of the Oil Industries. (Outlines of Industrial Chemistry.)	8vo,	*3 00
Soxhlet, D. H. Dyeing and Staining Marble. Trans. by A. Morris and H. Robson	8vo,	*2 50
Spang, H. W. A Practical Treatise on Lightning Protection	12mo,	1 00
Spangenburg, L. Fatigue of Metals. Translated by S. H. Shreve. (Science Series No. 23.)	16mo,	0 50
Specht, G. J., Hardy, A. S., McMaster, J. B., and Walling. Topographical Surveying. (Science Series No. 72.)	16mo,	0 50
Spencer, A. S. Design of Steel-Framed Sheds	8vo,	*4 00
Speyers, C. L. Text-book of Physical Chemistry	8vo,	*2 25
Spiegel, L. Chemical Constitution and Physiological Action. (Trans. by C. Luedeking and A. C. Boylston.)		1 25
Sprague, E. H. Hydraulics	12mo,	1 25
Stahl, A. W. Transmission of Power. (Science Series No. 28.)	16mo,	
Stahl, A. W., and Woods, A. T. Elementary Mechanism	12mo,	*2 00
Staley, C., and Pierson, G. S. The Separate System of Sewerage	8vo,	*3 00
Standage, H. C. Leatherworkers' Manual	8vo,	*3 50
— Sealing Waxes, Wafers, and Other Adhesives	8vo,	*2 00
— Agglutinants of all Kinds for all Purposes	12mo,	*3 50
Stanley, H. Practical Applied Physics. (In Press.)		
Stansbie, J. H. Iron and Steel. (Westminster Series.)	8vo,	*2 00
Steadman, F. M. Unit Photography	12mo,	*2 00
Stecher, G. E. Cork. Its Origin and Industrial Uses	12mo,	1 00
Steinman, D. B. Suspension Bridges and Cantilevers. (Science Series No. 127.)		0 50
— Melan's Steel Arches and Suspension Bridges	8vo,	*3 00
Stevens, H. P. Paper Mill Chemist	16mo,	*2 50
Stevens, J. S. Theory of Measurements	12mo,	*1 25
Stevenson, J. L. Blast-Furnace Calculations	12mo, leather,	*2 00
Stewart, G. Modern Steam Traps	12mo,	*1 25
Stiles, A. Tables for Field Engineers	12mo,	1 00
Stodola, A. Steam Turbines. Trans. by L. C. Loewenstein	8vo,	*5 00
Stone, H. The Timbers of Commerce	8vo,	3 50
Stopes, M. Ancient Plants	8vo,	*2 00
— The Study of Plant Life	8vo,	*2 00
Stumpf, Prof. Una-Flow of Steam Engine	4to,	*3 50
Sudborough, J. J., and James, T. C. Practical Organic Chemistry	12mo,	*2 00
Suffling, E. R. Treatise on the Art of Glass Painting	8vo,	*3 50
Sur, F. J. S. Oil Prospecting and Extracting	8vo,	*1 00

Swan, K. Patents, Designs and Trade Marks. (Westminster Series.)	8vo,	*2 00
Swinburne, J., Wordingham, C. H., and Martin, T. C. Electric Currents. (Science Series No. 109.)	16mo,	0 50
Swoope, C. W. Lessons in Practical Electricity	12mo,	*2 00
Tailfer, L. Bleaching Linen and Cotton Yarn and Fabrics	8vo,	*5 00
Tate, J. S. Surcharged and Different Forms of Retaining-walls. (Science Series No. 7.)	16mo,	0 50
Taylor, F. N. Small Water Supplies	12mo,	*2 00
— Masonry in Civil Engineering	8vo,	*2 50
Taylor, T. U. Surveyor's Handbook	12mo, leather,	*2 00
— Backbone of Perspective	12mo,	*1 00
Taylor, W. P. Practical Cement Testing	8vo,	*3 00
Templeton, W. Practical Mechanic's Workshop Companion.	12mo, morocco,	2 00
Tenney, E. H. Test Methods for Steam Power Plants. (Van Nostrand's Textbooks.)	12mo,	*2 50
Terry, H. L. India Rubber and its Manufacture. (Westminster Series.)	8vo,	*2 00
Thayer, H. R. Structural Design. 8vo.		
Vol. I. Elements of Structural Design		*2 00
Vol. II. Design of Simple Structures		*4 00
Vol. III. Design of Advanced Structures		(In Preparation.)
— Foundations and Masonry		(In Preparation.)
Thiess, J. B., and Joy, G. A. Toll Telephone Practice	8vo,	*3 50
Thom, C., and Jones, W. H. Telegraphic Connections	oblong, 12mo,	1 50
Thomas, C. W. Paper-makers' Handbook		(In Press.)
Thompson, A. B. Oil Fields of Russia	4to,	*7 50
Thompson, S. P. Dynamo Electric Machines. (Science Series No. 75.)	16mo,	0 50
Thompson, W. P. Handbook of Patent Law of All Countries	16mo,	1 50
Thomson, G. S. Milk and Cream Testing	12mo,	*1 75
— Modern Sanitary Engineering, House Drainage, etc.	8vo,	*3 00
Thornley, T. Cotton Combing Machines	8vo,	*3 00
— Cotton Waste	8vo,	*3 00
— Cotton Spinning. 8vo.		
First Year		*1 50
Second Year		*2 50
Third Year		*2 50
Thurso, J. W. Modern Turbine Practice	8vo,	*4 00
Tidy, C. Meymott. Treatment of Sewage. (Science Series No. 94.)	16mo,	0 50
Tillmans, J. Water Purification and Sewage Disposal. Trans. by Hugh S. Taylor	8vo,	*2 00
Tinney, W. H. Gold-mining Machinery	8vo,	*3 00
Titherley, A. W. Laboratory Course of Organic Chemistry	8vo,	*2 00
Toch, M. Chemistry and Technology of Mixed Paints	8vo,	*3 00
— Materials for Permanent Painting	12mo,	*2 00
— Chemistry and Technology of Mixed Paints		(In Press.)
Tod, J., and McGibbon, W. C. Marine Engineers' Board of Trade Examinations	8vo,	*1 50

D. VAN NOSTRAND CO.'S SHORT TITLE CATALOG 29

Todd, J., and Whall, W. B. Practical Seamanship	8vo,	*7 50
Tonge, J. Coal. (Westminster Series.)	8vo,	*2 00
Townsend, F. Alternating Current Engineering	8vo, boards,	*0 75
Townsend, J. Ionization of Gases by Collision.	8vo,	*1 25
Transactions of the American Institute of Chemical Engineers, 8vo. Seven volumes now ready. Vol. I. to VII., 1908-1914.	8vo, each,	*6 00
Traverse Tables. (Science Series No. 115.)	16mo,	0 50
	morocco,	1 00
Treiber, E. Foundry Machinery. Trans. by C. Salter.	12mo,	1 25
Trinks, W., and Housum, C. Shaft Governors. (Science Series No. 122.)	16mo,	0 50
Trowbridge, W. P. Turbine Wheels. (Science Series No. 44.)	16mo,	0 50
Tucker, J. H. A Manual of Sugar Analysis	8vo,	3 50
Tunner, P. A. Treatise on Roll-turning. Trans. by J. B. Pearse. 8vo, text and folio atlas,		10 00
Turnbull, Jr., J., and Robinson, S. W. A Treatise on the Compound Steam-engine. (Science Series No. 8.)	16mo,	
Turrill, S. M. Elementary Course in Perspective	12mo,	*1 25
Twyford, H. B. Purchasing.	8vo,	*3 00
Tyrell, H. G. Design and Construction of Mill Buildings.	8vo,	*4 00
— Concrete Bridges and Culverts.	16mo, leather,	*3 00
— Artistic Bridge Design.	8vo,	*3 00
Underhill, C. R. Solenoids, Electromagnets and Electromagnetic Wind- ings.	12mo,	*2 00
Underwood, N., and Sullivan, T. V. Chemistry and Technology of Printing Inks	8vo,	*3 00
Urquhart, J. W. Electric Light Fitting	12mo,	2 00
— Electro-plating.	12mo,	2 00
— Electrotyping	12mo,	2 00
Usborne, P. O. G. Design of Simple Steel Bridges	8vo,	*4 00
Vacher, F. Food Inspector's Handbook.	12mo,	*3 00
Van Nostrand's Chemical Annual. Third issue 1913.	leather, 12mo,	*2 50
— Year Book of Mechanical Engineering Data.	(In Press.)	
Van Wagenen, T. F. Manual of Hydraulic Mining	16mo,	1 00
Vega, Baron Von. Logarithmic Tables	8vo, cloth, half morocco,	2 00 2 50
Vincent, C. Ammonia and its Compounds. Trans. by M. J. Salter. 8vo.		*2 00
Volk, C. Haulage and Winding Appliances	8vo,	*4 00
Von Georgievics, G. Chemical Technology of Textile Fibres. Trans. by C. Salter	8vo,	*4 50
— Chemistry of Dyestuffs. Trans. by C. Salter	8vo,	*4 50
Vose, G. L. Graphic Method for Solving Certain Questions in Arithmetic and Algebra (Science Series No. 16.)	16mo,	0 50
Vosmaer, A. Ozone.	(In Press.)	
Wabner, R. Ventilation in Mines. Trans. by C. Salter	8vo,	*4 50
Wade, E. J. Secondary Batteries.	8vo,	*4 00

Wadmore, T. M. Elementary Chemical Theory.....	12mo,	*1 50
Wadsworth, C. Primary Battery Ignition.....	12mo,	*0 50
Wagner, E. Preserving Fruits, Vegetables, and Meat.....	12mo,	*2 50
Waldram, P. J. Principles of Structural Mechanics.....	12mo,	*3 00
Walker, F. Aerial Navigation.....	8vo,	2 00
— Dynamo Building. (Science Series No. 98.).....	16mo,	0 50
Walker, F. Electric Lighting for Marine Engineers.....	8vo,	2 00
Walker, J. Organic Chemistry for Students of Medicine.....	8vo,	*2 50
Walker, S. F. Steam Boilers, Engines and Turbines.....	8vo,	3 00
— Refrigeration, Heating and Ventilation on Shipboard.....	12mo,	*2 00
— Electricity in Mining.....	8vo,	*3 50
Wallis-Taylor, A. J. Bearings and Lubrication.....	8vo,	*1 50
— Aerial or Wire Ropeways.....	8vo,	*3 00
— Motor Vehicles for Business Purposes.....	8vo,	3 50
— Refrigeration, Cold Storage and Ice-Making.....	8vo,	*4 50
— Sugar Machinery.....	12mo,	*2 00
Walsh, J. J. Chemistry and Physics of Mining and Mine Ventilation,	12mo,	*2 00
Wanklyn, J. A. Water Analysis.....	12mo,	2 00
Wansbrough, W. D. The A B C of the Differential Calculus.....	12mo,	*1 50
— Slide Valves.....	12mo,	*2 00
Waring, Jr., G. E. Sanitary Conditions. (Science Series No. 31.).....	16mo,	0 50
— Sewerage and Land Drainage.....		*6 00
Waring, Jr., G. E. Modern Methods of Sewage Disposal.....	12mo,	2 00
— How to Drain a House.....	12mo,	1 25
Warnes, A. R. Coal Tar Distillation.....	8vo,	*2 50
Warren, F. D. Handbook on Reinforced Concrete.....	12mo,	*2 50
Watkins, A. Photography. (Westminster Series.).....	8vo,	*2 00
Watson, E. P. Small Engines and Boilers.....	12mo,	1 25
Watt, A. Electro-plating and Electro-refining of Metals.....	8vo,	*4 50
— Electro-metallurgy.....	12mo,	1 00
— The Art of Soap Making.....	8vo,	3 00
— Leather Manufacture.....	8vo,	*4 00
— Paper-Making.....	8vo,	3 00
Weather and Weather Instruments.....	12mo,	1 00
	paper,	0 50
Webb, H. L. Guide to the Testing of Insulated Wires and Cables.....	12mo,	1 00
Webber, W. H. Y. Town Gas. (Westminster Series.).....	8vo,	*2 00
Weisbach, J. A Manual of Theoretical Mechanics.....	8vo,	*6 00
	sheep,	*7 50
Weisbach, J., and Herrmann, G. Mechanics of Air Machinery.....	8vo,	*3 75
Welch, W. Correct Lettering.....	(In Press.)	
Wells, M. B. Steel Bridge Designing.....	8vo,	*2 50
Weston, E. B. Loss of Head Due to Friction of Water in Pipes.....	12mo,	*1 50
Weymouth, F. M. Drum Armatures and Commutators.....	8vo,	*3 00
Wheatley, O. Ornamental Cement Work.....	8vo,	*2 00
Wheeler, J. B. Art of War.....	12mo,	1 75
— Field Fortifications.....	12mo,	1 75

Whipple, S. An Elementary and Practical Treatise on Bridge Building.	8vo,	3 00
White, A. T. Toothed Gearing.....	12mo,	*1 25
White, C. H. Methods of Metallurgical Analysis. (Van Nostrand's Textbooks.)	12mo,	2 50
Wilcox, R. M. Cantilever Bridges. (Science Series No. 25.)....	16mo,	0 50
Wilda, H. Steam Turbines. Trans. by C. Salter.....	12mo,	1 25
— Cranes and Hoists. Trans. by C. Salter.....	12mo,	1 25
Wilkinson, H. D. Submarine Cable Laying and Repairing.....	8vo,	*6 00
Williamson, J. Surveying.....	8vo,	*3 00
Williamson, R. S. On the Use of the Barometer.....	4to,	15 00
— Practical Tables in Meteorology and Hypsometry.....	4to,	2 50
Wilson, F. J., and Heilbron, I. M. Chemical Theory and Calculations.	12mo,	*1 00
Wilson, J. F. Essentials of Electrical Engineering..... (In Press.)		
Wimperis, H. E. Internal Combustion Engine.....	8vo,	*3 00
— Application of Power to Road Transport.....	12mo,	*1 50
— Primer of Internal Combustion Engine.....	12mo,	*1 00
Winchell, N. H., and A. N. Elements of Optical Mineralogy....	8vo,	*3 50
Winslow, A. Stadia Surveying. (Science Series No. 77.).....	16mo,	0 50
Wisser, Lieut. J. P. Explosive Materials. (Science Series No. 70.)	16mo,	0 50
Wisser, Lieut. J. P. Modern Gun Cotton. (Science Series No. 89.)	16mo,	0 50
Wolf, C. E. Modern Locomotive Practice.....	8vo,	*4 20
Wood, De V. Luminiferous Aether. (Science Series No. 85)....	16mo,	0 50
Wood, J. K. Chemistry of Dyeing. (Chemical Monographs No. 2.)	12mo,	*0 75
Worden, E. C. The Nitrocellulose Industry. Two Volumes.....	8vo,	*10 00
— Technology of Cellulose Esters. In 10 volumes. 8vo.		
Vol. VIII. Cellulose Acetate.....		*5 00
Wren, H. Organometallic Compounds of Zinc and Magnesium. (Chemical Monographs No. 1.).....	12mo,	*0 75
Wright, A. C. Analysis of Oils and Allied Substances.....	8vo,	*3 50
— Simple Method for Testing Painters' Materials.....	8vo,	*2 50
Wright, F. W. Design of a Condensing Plant.....	12mo,	*1 50
Wright, H. E. Handy Book for Brewers.....	8vo,	*5 00
Wright, J. Testing, Fault Finding, etc., for Wiremen. (Installation Manuals Series.).....	16mo,	*0 50
Wright, T. W. Elements of Mechanics.....	8vo,	*2 50
Wright, T. W., and Hayford, J. F. Adjustment of Observations....	8vo,	*3 00
Young, J. E. Electrical Testing for Telegraph Engineers.....	8vo,	*4 00
Zahner, R. Transmission of Power. (Science Series No. 40.)....	16mo,	
Zeidler, J., and Lustgarten, J. Electric Arc Lamps.....	8vo,	*2 00
Zeuner, A. Technical Thermodynamics. Trans. by J. F. Klein. Two Volumes.....	8vo,	*8 00
Zimmer, G. F. Mechanical Handling of Material.....	4to,	*10 00
Zipser, J. Textile Raw Materials. Trans. by C. Salter.....	8vo,	*5 00
Zur Nedden, F. Engineering Workshop Machines and Processes. Trans. by J. A. Davenport.....	8vo,	*2 00

D. VAN NOSTRAND COMPANY

are prepared to supply, either from
their complete stock or at
short notice,

Any Technical or Scientific Book

In addition to publishing a very large and varied number of SCIENTIFIC AND ENGINEERING BOOKS, D. Van Nostrand Company have on hand the largest assortment in the United States of such books issued by American and foreign publishers.

All inquiries are cheerfully and carefully answered and complete catalogs sent free on request.

25 PARK PLACE NEW YORK

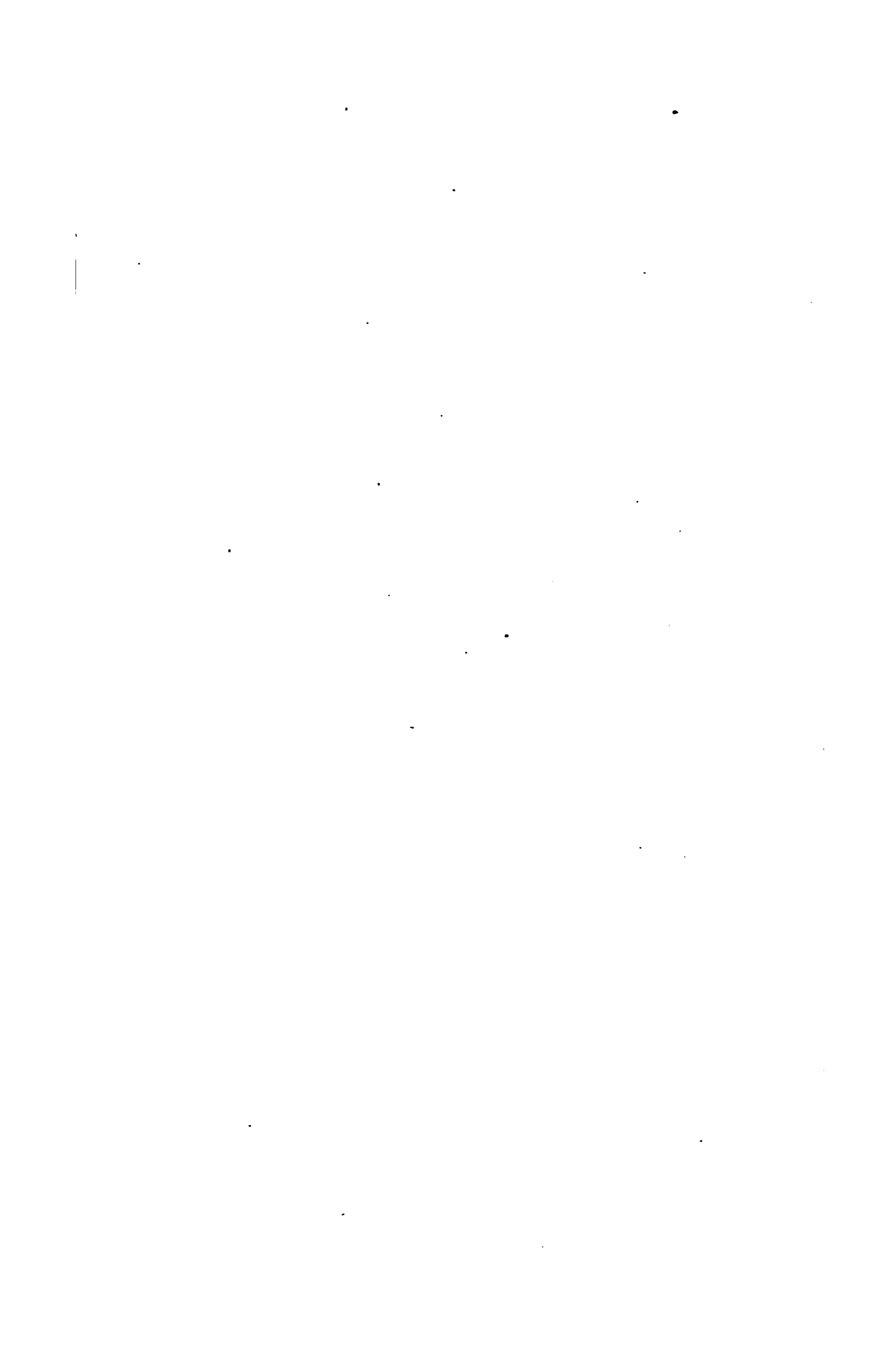

89083903385

TR:



B89083903385A

$\frac{1711}{300}$



89083903385



b89083903385a